

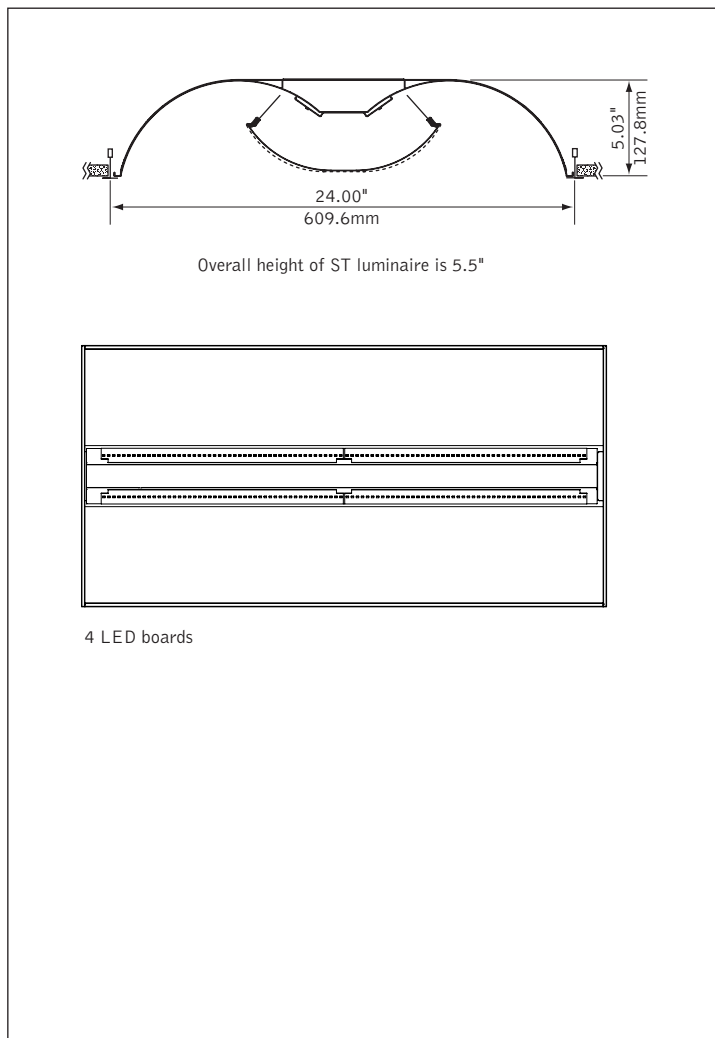

DIMENSIONAL DATA



FEATURES

- Architectural recessed LED luminaire with perforated center basket.
- Classic style updated with the latest technology.
- Reflector and end caps form seamless one-piece housing.
- High reflectance, low gloss Matte White finish controls glare.
- Comparable output to fluorescent versions with reduced wattage.
- Luna[®] LED provides high angle uniform distribution ideal for comfortable general illumination.
- Connected Solutions: Integrates with wired and wireless building lighting control systems.
- Preferred Light: Lighting for better color rendition and human preference.

PERFORMANCE

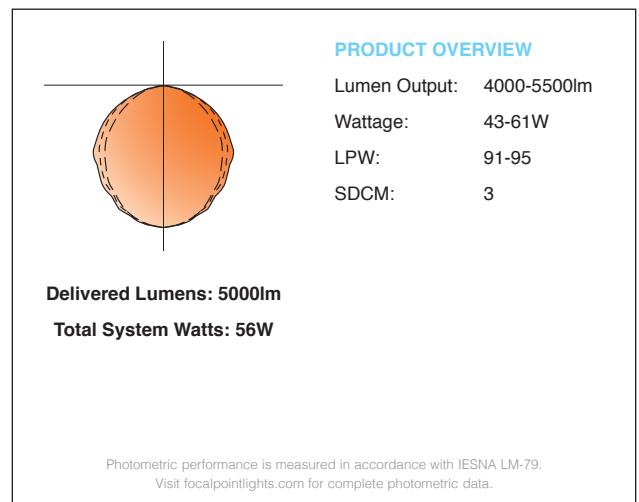

fixture:

project:

MOUNTING INFORMATION

grid

specify "G" for flat 9/16" and 15/16" tee or "ST" for 9/16" slot tee grid types.

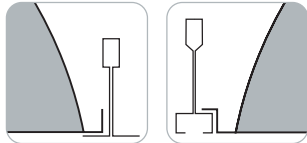

"G" flat tee "ST" slot tee

Overall height for ST luminaire is 5.50".

drywall frame kit

specify "DF" Drywall Frame Kit for drywall ceiling conditions.

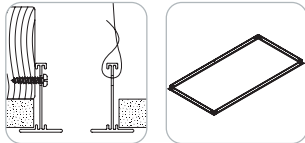

Use tie-wire or screws to secure frame kit.

cut out dimensions:
 2': Min: 24.25" Max: 24.563"
 4': Min: 48.25" Max: 48.563"

SPECIFICATIONS

LED System

Proprietary linear LED module incorporates premium LEDs on a robust platform to achieve excellent thermal management. LEDs are placed to promote a uniform appearance. Available in 2700K, 3000K, 3500K or 4000K with CRI>80 or CRI>90. 0-10V dimming driver standard. LED modules and drivers are replaceable.

Construction

One-piece 20 Ga. steel reflector and housing. 20 Ga. steel ends form finished housing. LEDs are shielded by detachable 22 Ga. steel perforated shield with acrylic lens insert. LED shield is secured by four spring-pins allowing shield to hinge down for maintenance. Top access 20 Ga. steel driver compartment. Weight: 29 lbs.

Optic

One-piece 20 Ga. steel reflectors finished in Matte Satin White powder coat.

Electrical

Standard 120-277V driver includes 0-10V analog dimming, dimming range 100% - 10% Power factor > .9.

Emergency Battery

Bodine BSL310-CAN. Emergency output—10 watts for 90 minutes.
 Bodine BSL20LV (U.S. only). Emergency output—20 watts for 90 minutes.

Labels

UL and cUL Listed. Suitable for Dry or Damp Locations, indoor use only.

Finish

Polyester powder coat applied over a multi-stage pre-treatment.

Lumen Maintenance

Reported: L70 > 60,000 hours Calculated: L70 at > 124,000 hours
 L80 > 60,000 hours L80 at > 78,000 hours

(Derived from EPA TM-21 calculator. Based on typical conditions, consult factory for additional data.)

Reliability

At Focal Point, our products are designed to stand the test of time. Each luminaire is engineered using superior components, manufactured with the utmost care and rigorously tested. Contact us for reliability data.

Lifetime and warranty

LED System rated for operation in ambient environments up to 25°C. 5-year limited warranty.

PERFORMANCE CHART

Delivered Lumens	Tested System Watts	LPW
4000 Lumens	43	95
4500 Lumens	48	94
5000 Lumens	56	92
5500 Lumens	61	91

Based on 3500K, 80 CRI. Lumen multipliers: Preferred Light = 0.65, 90+ CRI = 0.87. Lumen output may vary +/- 5%. Actual wattage may vary +/- 5%.

ORDERING

Luminaire Series	FLUL
Luna LED	FLUL
Nominal Size	24
2' x 4'	24
Shielding	PS
Perforated Shield	PS
Lumen Output	
4000 Lumens	4000L
4500 Lumens	4500L
5000 Lumens	5000L
5500 Lumens	5500L
Color Temperature	
2700K, 80+ CRI or 90+ CRI	27K or 927K
3000K, 80+ CRI or 90+ CRI	30K or 930K
3500K, 80+ CRI or 90+ CRI	35K or 935K
4000K, 80+ CRI or 90+ CRI	40K or 940K
3500K, Preferred Light	P35K
Circuit	1C
Single Circuit	1C
Voltage	
UNV 120/277 Volt	UNV
Control System & Dimming Level	
0-10V - 1% Dimming	L11
0-10V - 10% Dimming	LD1
Lutron Hi-Lume EcoSystem (LDE1) - 1% Dimming	LH1
Lutron 5-Series EcoSystem (LDE5) - 5% Dimming	LU5
Acuty nLight - 1% Dimming (Not available with CP)	NLT1
Enlighted Smart Sensor - 1% Dimming	ENL1
Osram Connected Lighting Module for ENCELIIUM systems - 1% Dimming (Compatible with Osram ENCELIIUM and ENCELIIUM EDGE systems only)	CLM1
Osram Connected Lighting Module for ZigBee Wireless Networks - 1% Dimming (Not compatible with Osram ENCELIIUM systems)	CLMZ1
Wattstopper DLM - 1% Dimming	DLM1
Mounting	
24" Aircraft Cable	C24
48" Aircraft Cable	C48
96" Aircraft Cable	C96
Drywall Frame Kit (LD1, L11, LH1 & LU5 only) (Cut out dimensions: Min: 24.25"/Max: 24.563" Min: 48.25"/Max: 48.563")	F
Grid	G
Slot Tee	ST
Surface Mount (Not available with DLM1 or NLT1)	SM
Factory Options	
Air Return (Adds 0.875" to overall height)	AR
Chicago Plenum	CP
Bodine BSL310 Emergency Battery (Adds 3.25" to overall height)	B310
Bodine BSL20LV High Output Emergency Battery (Adds 3.25" to overall height. U.S. Only)	B20
Positional Clip	EQ
6' New York City Flex Whip (120V)	FNY1
6' New York City Flex Whip (277V)	FNY2
6' Flex Whip	FW
Finish	WH
Matte Satin White	WH



Options in orange qualify for the Quickship program. 5-day up to 100 pieces, 10-day up to 300 pieces. Refer to Quickship Guide for complete details.

Focal Point provides flexibility in meeting the needs of each project by integrating with several building lighting control systems. A variety of sensors, drivers and other components can be specified that allow the luminaires to communicate with wired and wireless networks. All zoning can be digitally reconfigured through the application software. Daylight harvesting, occupancy sensing, integration with HVAC systems, and individual controls enable the monitoring and modulating of light levels and temperature in order to save energy, reduce costs and maximize occupants' comfort. All Connected Solutions luminaires require a compatible building control system.†

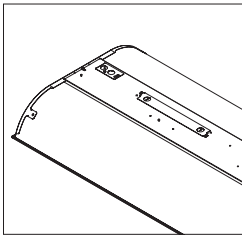

nLight[®] provides a two-way wired digital lighting system allowing for on/off and dimming functionality, occupancy sensing, and multi-zone daylight harvesting.

Acuity nLight - 1% Dimming (NLT1)
Acuity Model #nEPS-60-IO

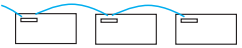

CAT-5 Cable provided by others. Serial labels will be provided on outside of luminaires and control unit.



Enlighted smart sensor allows for occupancy sensing, daylight harvesting, energy usage, temperature and light level control. Communicates wirelessly with the Enlighted network.

Enlighted Smart Sensor - 1% Dimming (ENL1)
Enlighted Model #SU-4E-01



Connected Lighting Module (CLM) enables each luminaire to be independently controlled and configured. Communicates wirelessly with Daintree Networks[®], Osram ENCELIUM[®], Osram ENCELIUM EDGE[™], and other networks using the ZigBee[®] HA communication protocol to allow for on/off and dimming functionality, occupancy sensing and multi-zone daylight harvesting.

Osram CLM - 1% Dimming (CLM1 & CLMZ1)
Osram Model #ZBHA-CLM DIM

Serial labels will be provided on outside of luminaires and control unit.

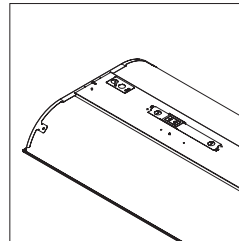

A Digital Lighting Management (DLM) system that provides two-way wired communication between networked luminaires and control system to allow for on/off and dimming functionality, occupancy sensing and multi-zone daylight harvesting.

Wattstopper DLM - 1% Dimming (DLM1)
Wattstopper Model #LMFC-011



CAT-5 Cable provided by others. Serial labels will be provided on outside of luminaires and control unit.

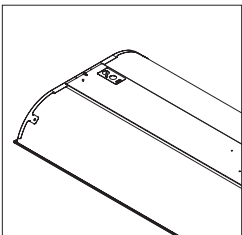

A two-way digital network that enables on/off and dimming functionality, occupancy sensing, and multi-zone daylight harvesting working with Quantum[®], Energi Savr Node[™], and Energi TriPak[®] using EcoSystem[®] communication protocol.

Lutron Hi-Lume EcoSystem - 1% Dimming (LH1)
Lutron Model #LDE1
Lutron 5-Series EcoSystem - 5% Dimming (LU5)
Lutron Model #LDE5

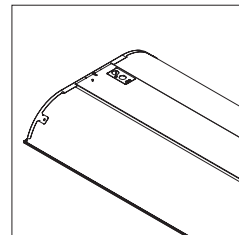

A two-way digital network that enables on/off and dimming functionality, occupancy sensing, and multi-zone daylight harvesting. Communicates with Züm wireless and SpaceBuilder working with Züm hub scheduling or FUSION management.

0-10V - 1% Dimming (L11)
Note: 0-10V is not a digital network but is compatible with Creston Züm[™] system.

CONNECTED SOLUTIONS DETAILS

Connected Solution	Model #	Protocol	Compatible Networks*	Occupancy	Daylight	Temperature Reporting	Communication to Luminaire	Drivers
Acuity nLight (NLT1)	nEPS-60-IO**	nLight	nLight	Enabled	Enabled	No	Wired	eldoLED ECOdrive , eldoLED SOLOdrive
Crestron (L11)	Specified Driver	0-10V	Crestron Züm Wireless & SpaceBuilder	Enabled	Enabled	No	Wired	Philips Xitanium
Enlighted Smart Sensor (ENL1)	SU-4E-01**	Enlighted RF	Enlighted	Integrated	Integrated	Yes	Wireless	Philips SimpleSet , Osram Optotronic
Legrand Wattstopper DLM (DLM1)	LMFC-011**	DLM	DLM	Enabled	Enabled	No	Wired	Philips SimpleSet , Osram Optotronic
Lutron EcoSystem (LH1 & LU5)	LDE1,** LDE5**	EcoSystem	Quantum, Energi Savr Node, Energi TriPak	Enabled	Enabled	No	Wired	Lutron Hi-Lume Lutron 5-Series
Osram CLM for ENCELIUM systems (CLM1)	ZBHA-CLM**	ZigBee HA	Osram ENCELIUM & ENCELIUM EDGE	Enabled	Enabled	No	Wireless	Osram Optotronic
Osram CLM for ZigBee Wireless Networks (CLMZ1)	ZBHA-CLM**	ZigBee HA	Daintree Networks & open ZigBee Networks	Enabled	Enabled	No	Wireless	Osram Optotronic

*Not all compatible networks may be listed. **For performance data and additional control system details please visit the connected solutions manufacturer websites. Primary drivers are listed in **bold**. To specify a particular driver please consult factory. †Controls systems supplied by others.