

EMPRESS 3035-35

PROJECT PROJET
SPEC TYPE
NOTES



FAMILY FAMILLE



3035-22 (CEILING)

4235-35

3035-35 (WALL)

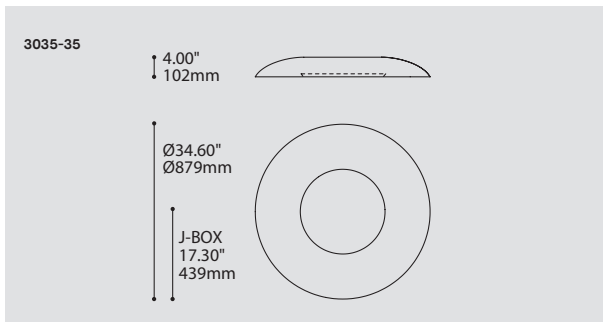

ORDERING SPECIFICATION	SPÉCIFICATION DE COMMANDE	CODE
MODEL MODÈLE		3035-35
3035-35	EMPRESS	
LIGHT SOURCE SOURCE LUMINEUSE		LED
(WATTAGE, LAMP TYPE, OTHER INFO)		
LED	REGULAR OUTPUT	
COLOR TEMPERATURE TEMPÉRATURE DE COULEUR		
30	3000K	
35	3500K	
40	4000K	
VOLTAGE VOLTAGE		
120V	120 VOLT	
277V	277 VOLT	
DIMMING OPTION OPTION DE GRADATION		
DV	0-10V DIMMING (120-277V)	
DP	PHASE DIMMING (120V ONLY)	
LED DIMMING DRIVER IS STANDARD IN THIS PRODUCT. PLEASE SPECIFY YOUR DIMMING TYPE.		
DECORATIVE PLATE FINISH FINI PLAQUE DÉCORATIVE		WHE
WHE	WHITE FINE TEXTURE	
DIFFUSER FINISH FINI DIFFUSEUR		WH
WH	WHITE	

PRODUCT CHARACTERISTICS CARACTÉRISTIQUES DU PRODUIT



DESIGN:	Formal purity and luxurious with its imposing size, it brings a gentle diffused indirect light and quiet sophistication to your interior space.
INSTALLATION:	The fixture installs on a standard junction box.
LIGHT SOURCE:	LED source creating an indirect light with a subtle back illumination.
STRUCTURE:	Die spun steel plate, available in white fine textured powder coat finish.
DIFFUSER:	Thermoformed matte white acrylic with frosted finish for optimal light diffusion. Available in 22" or 35" diameter.
CERTIFIED:	c-CSA-us
CONCEPTION:	D'une forme pure et luxueuse en raison de son imposante taille, cette applique murale apportera un éclairage indirect et délicatement diffus à votre espace.
INSTALLATION:	Le luminaire s'installe simplement sur une boîte de jonction standard.
SOURCE LUMINEUSE:	Module DEL créant un éclairage indirect frontal et une légère illumination arrière.
STRUCTURE:	Fait d'acier repoussé et offert avec notre finition architecturale blanche finement texturée.
DIFFUSEUR:	Acrylique mat thermoformé et givré pour une diffusion lumineuse optimale. Offert en diamètres de 22" et 35".
CERTIFIÉ:	c-CSA-us

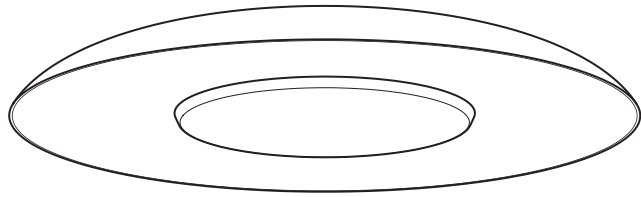

INDIRECT AND AMBIENT LIGHT

Design for a indirect lighting with an ambient outer glow.
Empress is suited for many installation context.

HIGH DIFFUSION
Custom made thermoformed and frosted white PMMA reflector for a soft and even light.

MOUNTING SYSTEM
For an easier and simpler installation on the wall and ceiling surface.

DEEP JUNCTION BOX
3035-22 installs to deep junction box (3983)

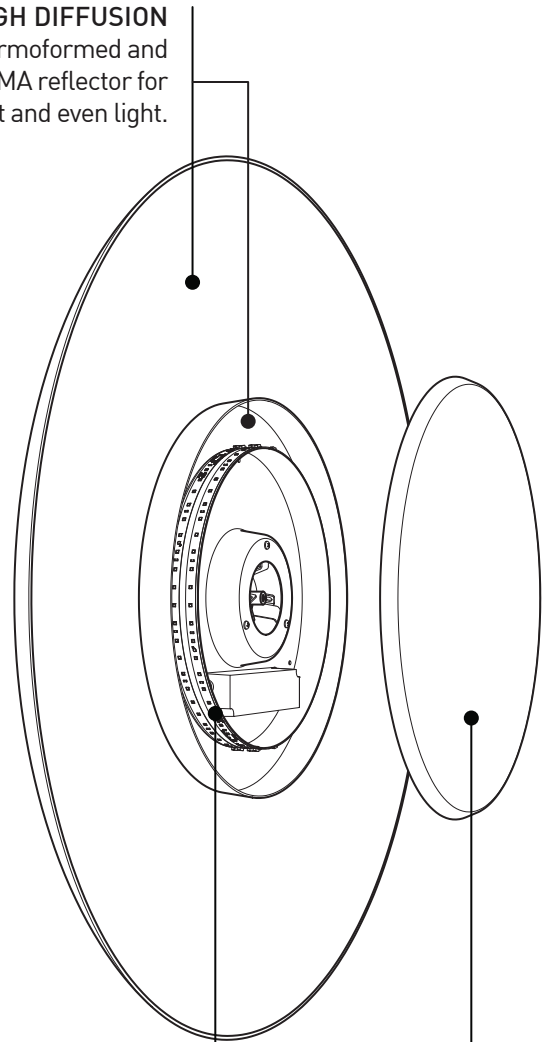
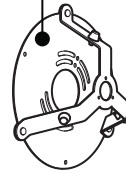
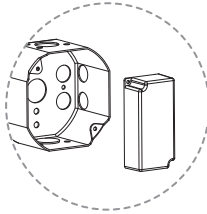

LED MODULES
Custom made high performance LED ring for a total of 22W or 30W.

FRONT PLATE
Die-spun steel dish, available in white architectural grade fine textured finishes.

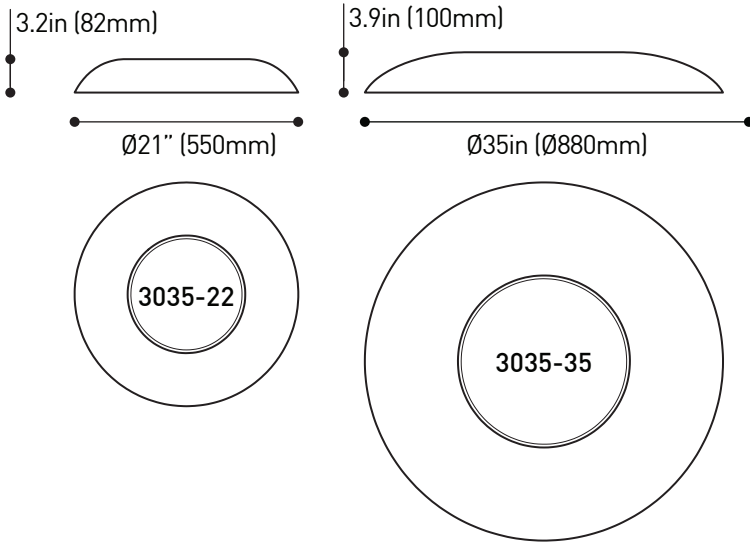

CHARACTERISTICS	3035-22	3035-35
LIGHT SOURCE	78 x Nichia	156 x Nichia
DELIVERED LUMENS	1273 lumens	1991 lumens
SYSTEM WATTAGE	22W	30W
IRC	83 CRI (typique)	
LIGHT DISTRIBUTION	Semi-direct and ambient illumination	
DIFFUSOR	Thermoformed and frosted white PMMA	
STRUCTURE	Die-spun steel dish, available in white architectural grade fine textured finishes	
VOLTAGE	120V (DP) or 120-277V (DV)	
DIMMING	Phase dimming (DP) and 0-10V dimming (DV)	
WARRANTY	5 years	

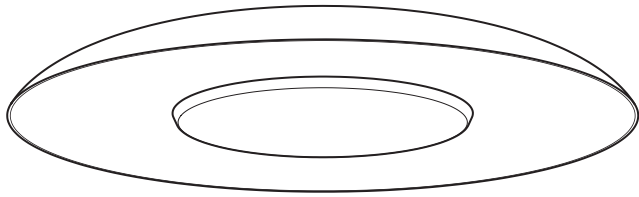

LUMIÈRE INDIRECTE

Luminaire conçu pour un éclairage principal indirect avec une illumination ambiante indirecte, permettant une versatilité dans plusieurs contextes d'installations.

SYSTÈME D'INSTALLATION

Pour une installation simple et rapide sur une surface murale ou au plafond.

BOITE OCTOGONALE PROFONDE
3035-22 Installé à boîte de jonction profonde (3983)

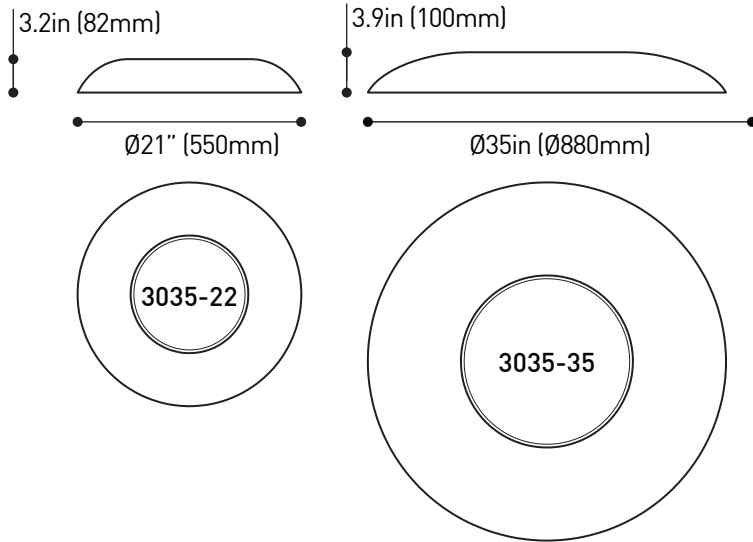
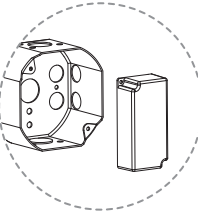

HAUTE DIFFUSION

Diffuseur moulé sur mesure en PMMA blanc givré pour une lumière douce et uniforme.

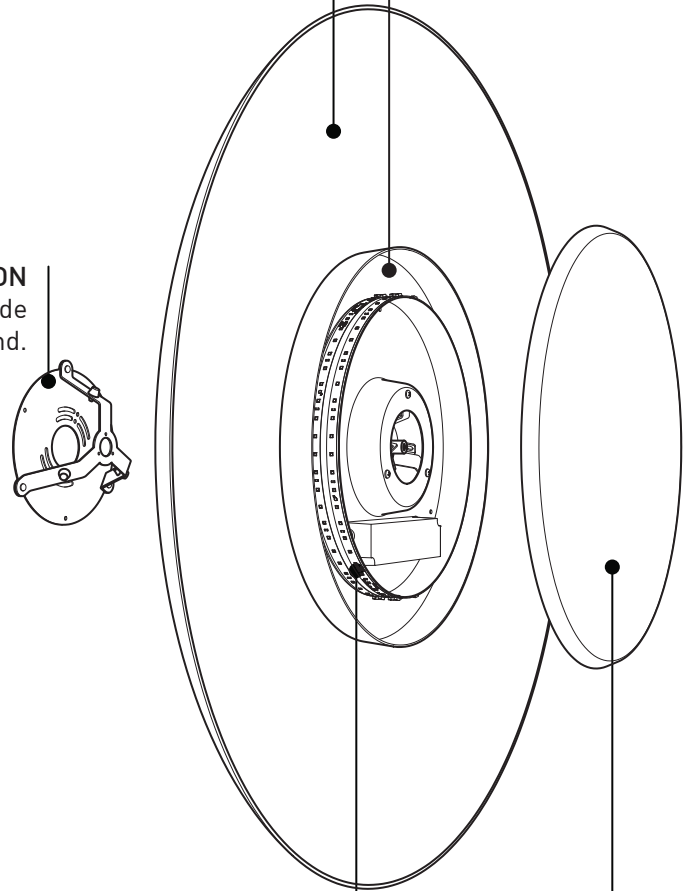

MODULES DEL

Modules DEL (bandes) haute performance conçu sur mesure pour un total de 22W ou 30W.

FAÇADE

Fait d'acier repoussé et offert avec notre finition architecturale finement texturée blanche.

CARACTÉRISTIQUES 3035-22

SOURCE LUMINEUSE	78 x Nichia
LUMENS RÉELS	1273 lumens
WATTAGE DU SYSTEM	22W
IRC	83 CRI (typique)
DISTRIBUTION LUMINEUSE	Illumination semi-direct et ambiante
DIFFUSEUR	PMMA blanc thermoformé et givré
STRUCTURE	Acier repoussé, fini architecturale finement texturée blanche
VOLTAGE	120V (DP) ou 120-277V (DV)
GRADATION	Gradation "phase" (DP) et gradation "0-10V" (DV)
GARANTIE	5 ans

3035-35

SOURCE LUMINEUSE	156 x Nichia
LUMENS RÉELS	1991 lumens
WATTAGE DU SYSTEM	30W