

Project \_\_\_\_\_

Type \_\_\_\_\_

Notes \_\_\_\_\_

**PERFORMANCE PER LINEAR FOOT AT 4000K**

NOMINAL LUMEN OUTPUT	INPUT WATTS*	EFFICACY
400 lm/ft	3.6 W/ft	111 lm/W
500 lm/ft	4.7 W/ft	106 lm/W
750 lm/ft	7.5 W/ft	100 lm/W
1000 lm/ft	10.4 W/ft	96 lm/W

\* Based on a 4 foot luminaire using one driver  
Please consult factory for custom lumen output and wattage.



**Ordering Guide**

TBWDLED					SO						
PRODUCT ID		NOM. LUMENS/FT		CRI		COLOR TEMP.		SHIELDING		LENGTH (FT)	
TBWDLED	Wall Direct LED	400	400 lm/ft	80	80 CRI	27	2700 K	SO	spotless lens	2	2'
		500	500 lm/ft	90	90 CRI	30	3000 K			3	3'
		750	750 lm/ft			35	3500 K			4	4'
		1000	1000 lm/ft			40	4000 K			5	5'
										6	6'
										8	8'
										12	12'
										S#	system run
		Outputs between listed min and max are available. Consult factory for outputs outside of the listed range.									

MR (OPTIONAL)		FINISH		VOLTAGE		DRIVER		CIRCUITS			BATTERY (OPTIONAL)	
M11LED(#)	MR11 LED	AP	aluminum paint	120	120 V	DP	dimming (0-10V) 1%	1	1 circuit	B#	battery pack (integral)	
		W	white	277	277 V	D	dimming (0-10V) 5% 347V standard (2)	2	2 circuits			
		BLK	black	347	347 V (4)	LT	Lutron (3)	+E(#)	emergency circuit (5)			
		C	custom	UNV	universal	BI	bi-level dimming	+NL(#)	night light circuit (5)			
						O	other (4)	+GTD(#)	generator transfer device (5)			
								+M	MR			
Add 6" per lamp, Specify quantity Separate circuits included Requires 120V or 277V				(1) D dimming (0-10V) 5% standard		(2) For 347V only (3) Specify system (4) Please consult factory; see page 2		(5) Specify quantity			Requires 120V or 277V Please consult factory	

OTHER (OPTIONAL)		IC CONTROLS (OPTIONAL)		CUSTOM (OPTIONAL)	
F	fuse (6)	DS#	daylight sensor	C	custom
D	dust cover	OS#	occupancy sensor		
		DOS#	daylight & occupancy sensor		
		EN#	Enlighted integral (7)		
		ENR#	Enlighted remote (7)		
(6) Requires 120V or 277V		(7) Please consult factory Specify quantity. Requires 8" blank. See pages 4-5 for more details.		Please specify	

● CONSTRUCTION

<b>Housing</b>	Extruded aluminum (0.075" nominal) Up to 70% recycled content
<b>End Cap</b>	Sheet steel (18 gauge)
<b>Interior Brackets</b>	Die formed sheet steel (20 gauge)
<b>Reflectors</b>	White powder coated sheet steel (22 gauge)
<b>Louvers</b>	Die formed semi-specular aluminum (22 gauge)
<b>Lenses</b>	Extruded acrylic (0.070" nominal) Satin: 68% trans. frosted: 85% trans.
<b>Hanger</b>	Die formed sheet steel (16 gauge)
<b>Suspension</b>	Aircraft cable or Ø 1/2" stem
<b>Cable Grips</b>	Quick connecting / release

● ELECTRICAL

<b>Lutron driver</b>	L3D - Hi-Lume A-Series EcoSystem 3-Wire Control (1%) LDE1 - EcoSystem H-Series (1%) LDE5 - EcoSystem 5-Series (5%) LTE - Hi-Lume® A-series 2Wires Forward Phase (1%)
<b>Other drivers</b>	DALI - Digital Addressable Lighting Interface DMX - Digital Multiplex LV - line voltage - Advance Mark 10 Xitanium SR - For wireless sensor
<b>Emergency</b>	Integral emergency battery pack or emergency circuit optional.
<b>Input Voltage</b>	120V, 277V, 347V, UNV.

**i** Incorporating these components may have limitations or affect the length of the luminaire. Please contact factory for more details.

● WARRANTY

Axis Lighting will warrant defective LEDs, boards, and drivers for 5 years from date of purchase. Warranty is valid if luminaire is installed and used according to specifications. If defective, Axis will send replacement boards or drivers at no cost along with detailed replacement instructions and instructions on how to return defective components to Axis.

● OPTICS

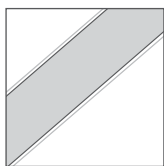

SO spotless lens

**SPOTLESS LENS**

Frosted acrylic snap-in lens with micro lens

● WEIGHT

<b>Wall Direct 4 ft</b>	13.2 lbs / 6.0 kg
<b>Wall Direct 8 ft</b>	26.4 lbs / 12.0 kg
<b>Wall Direct 12 ft</b>	39.6 lbs / 18.0 kg

● JOINERS

In order to allow very long runs of TWIN BEAM2 LED luminaires, Axis has developed an effective joining system. Special care has been taken to maximize the performance of the joiner for each BEAM option.

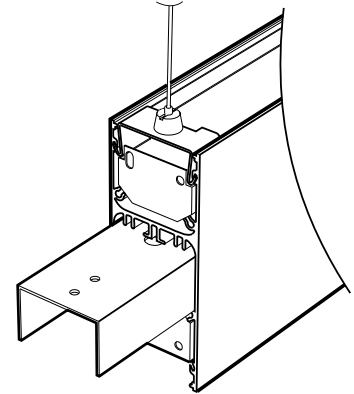

**NOTE:** Mount each system segment individually. Do not assemble system prior to mounting.

**i** Allow a minimum of 6" between end of long runs and vertical wall

● SYSTEM (S#)

TWIN BEAM2 LED linear systems, with the use of a strong profile, allow for a nearly hair thin connection system of continuous runs. Lengths of 4', 8', 12' as well as custom lengths are available. Runs of TWIN BEAM2 LED that are greater than 12' in length are designated as systems (S#). This means that the run is comprised of a combination of 4', 8' and/or 12' sections to be assembled on site using our joining system. For more information on systems and joining, please refer to the TWIN BEAM2 LED installation sheets available for download at [www.axislighting.com](http://www.axislighting.com).

● CORNERS

**Unlit Corners** - TWIN BEAM2 LED features a multitude of layout patterns with the use of a number of corners, 90° corner, T or X junctions.

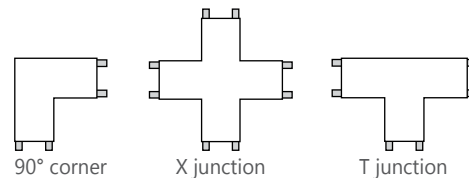
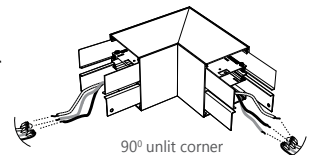

**Lit Corners** - In addition Axis offers Lit 90° corners including ceiling to ceiling, wall to ceiling and ceiling to wall.

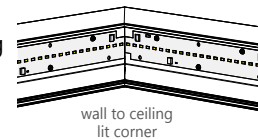

**i** For custom corner angles, please consult factory. Specifications sheets for all corners are available at: [www.axislighting.com](http://www.axislighting.com)

● HORIZONTAL MOUNTING DETAILS

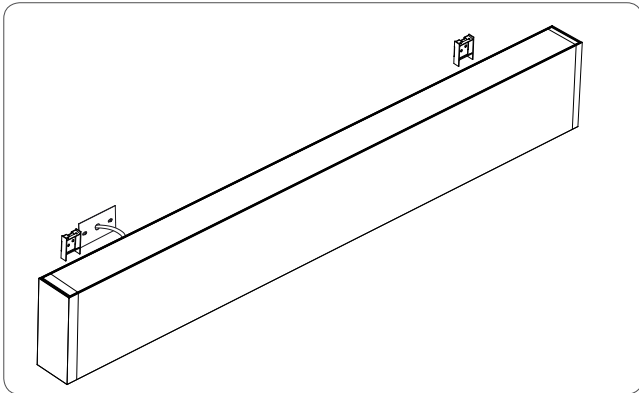

MOUNTING BRACKETS

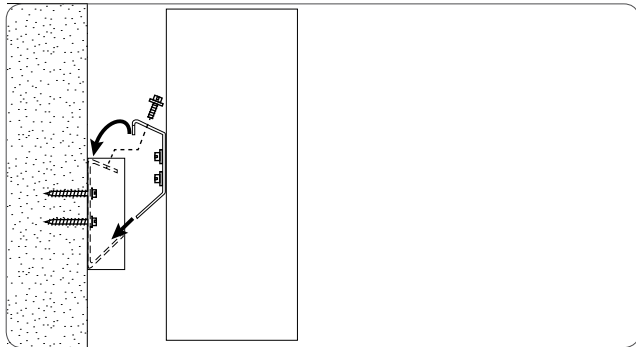

SIDE VIEW

● OTHER MOUNTING OPTIONS

TWIN BEAM2 LED is also available with pendant and asymmetric mounted options.

Specification sheets and installation sheets for all mountings for BEAM luminaires are available for download at [www.axislighting.com](http://www.axislighting.com)

● FINISH

Aluminium paint, powder coated and custom finishes are also available.

● APPROVALS

Certified to UL and CUL standards  
 Meets NYC requirements  
 Meets ADA requirements.  
 Suitable for damp locations.



● MR11 LED LAMPS

**Blank MR11 LED Quantity**

Extruded aluminum (0.075" nominal) 1.4" diameter  
 For every 4' section, there may be up to a maximum of 4 x MR11 LED lamps.

**Spacing**

Each MR11 LED lamp is placed centered on a blank section 6" in length.

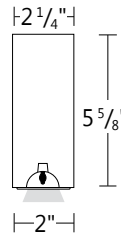

For a series of MR11's within a given section length, they will be spaced evenly on a longer blank section.  
 The directed light of MR11 LED lamps are fixed downward.  
 Custom spacing may be available on special request.

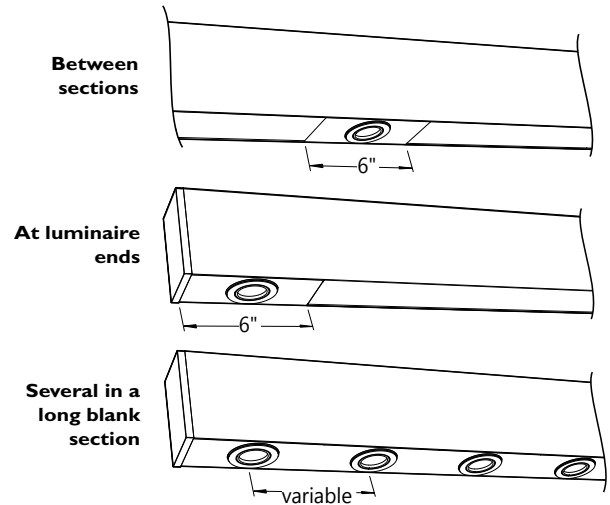

<b>Beam Angle</b>	45 nominal degrees
<b>Input Watts</b>	3W
<b>Nominal Lumens</b>	50 lumens
<b>Efficacy</b>	17 lumens per watt
<b>Color Rendering Index (CRI)</b>	80
<b>Life</b>	25,000 hours at L <sub>70</sub>
<b>Correlated color temperature (CCT)</b>	2700K

**i** More options are available upon request. Please consult factory.

● INTEGRATED CONTROLS

TWIN BEAM2 LED luminaires allow the use of integrated controls such as daylight sensors (DS), occupancy sensors (OS) and combination daylight/occupancy sensors (DOS). These options can be seamlessly integrated into our luminaires. The control system could be used to optimize the lighting of the space by reducing energy consumption through daylight harvesting and occupancy, thereby improving the overall interior environment and allowing for LEED credits.

- Consult factory for other options.

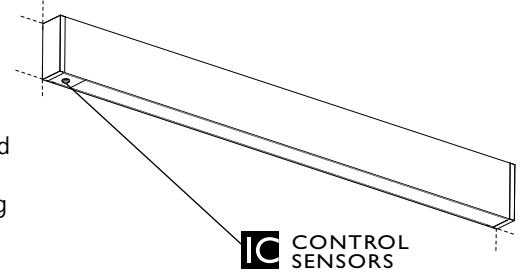

The integrated control systems offered are:

● DAYLIGHT HARVESTING (DS):

With Daylight sensors, maximum lamp output is reduced according to the available amount of natural light. By reducing maximum lamp output, energy consumption is reduced by up to 20 percent in a process known as "Daylight Harvesting".

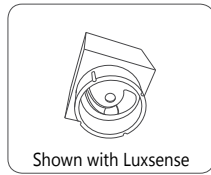

Shown with Luxsense  
EC-DIR-WH, FD-301  
Luxsense, Micro Luxsense

● OCCUPANCY (OS):

When a room is vacated, occupancy sensors ensure the light will be turned off after a programmed delay as well as ensuring that light remains on while the room is occupied.

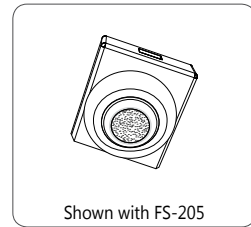

Shown with FS-205  
FS-205, FS-355,  
FS-155 - Line Voltage  
FS-505, FS-505C

● DAYLIGHT HARVESTING AND OCCUPANCY (DOS):

ACTILUME, a combination of Daylight & Occupancy sensor from Philips, along with a 0-10V or DALI driver can be used in one form factor.

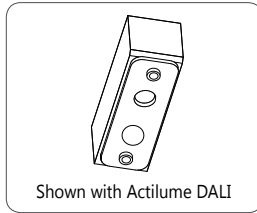

Shown with Actilume DALI  
Actilume 1-10V  
Actilume DALI

● ENLIGHTED INTEGRAL (EN) / ENLIGHTED REMOTE (ENR):

A combination of Daylight, Occupancy & Temperature autonomously control illumination levels, monitor occupancy and environmental conditions. Data is transmitted wirelessly to the Enlighted networked management system.

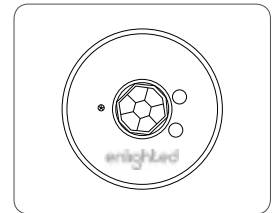

● INSTALLATION EXAMPLE

Sensor location option

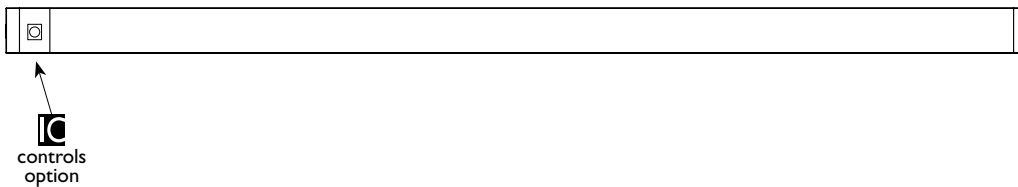

\* Incorporating IC controls may affect the length of the luminaire. Please contact factory for more details.

**● INTEGRATED CONTROL OPTIONS**

SENSORS	BRAND	Model	TYPE
Daylight Sensor (DS)	Lutron	EC-DIR-WH	Daylight, IR
	Wattstopper	FD-301	Daylight
	Philips	Luxsense, LR1220/00	Daylight
	Philips	Micro Luxsense	Daylight
	Wattstopper	LS-102	Light Saver (Ambient light level)
Occupancy Sensor (OS)	Wattstopper	FS-205v2	PIR Occupancy & Ambient light level
	Wattstopper	FS-355 (need lenses)	PIR Occupancy & Ambient light level
	Wattstopper	FS-155	PIR Occupancy & Ambient light level
	Wattstopper	FS-505	Ultrasonic Occupancy (Staircase)
	Wattstopper	FS-505C	Ultrasonic Occupancy (Open Area)
	Wattstopper	FM-105	High Frequency Occupancy (Wet)
	Lutron TriPak Wireless	LRF2-OCR2B-P-WH	PIR Occupancy
	Lutron	LOS-CDT	Ultrasonic Occupancy + PIR
Daylight & Occupancy Sensors (DOS)	Philips	Actilume, LR11655	Daylight & PIR Occupancy
	Wattstopper	FS-305 (need Lenses)	PIR Occupancy
	Wattstopper	FS-305 RC	PIR Occupancy & Ambient light level
	Creston	GLS Series	Daylight and/or PIR Occupancy
	Echoflex	MOS Series	Daylight and/or PIR Occupancy
Enlighted sensor (EN, ENR)	Enlighted integral / remote	SU-3E-00	Daylight, Occupancy & Temperature

● PHOTOMETRIC DATA

400 lm/ft

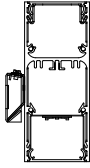

PHOTOMETRIC CURVE

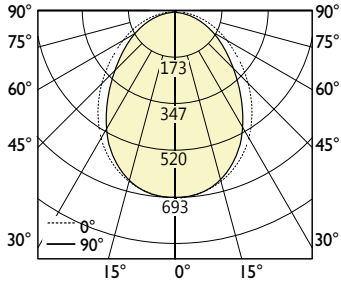

**Luminaire Lumens: 400 lm/ft**  
**Input Watts: 3.6 W/ft**  
**Efficacy: 111 lm/W**  
 IES FILE: TBWDLED-400-80-40-SO.IES

TESTED ACCORDING TO IES LM-79-2008

CANDELA DISTRIBUTION

Vertical Angle	Horizontal Angles				
	0	22.5	45	67.5	90
0	691	691	691	691	691
5	684	687	684	689	691
15	653	656	651	649	651
25	591	589	576	567	563
35	499	492	469	448	440
45	387	377	348	324	315
55	269	260	236	216	208
65	164	157	143	129	124
75	77	76	68	61	59
85	17	15	16	15	15
90	0	0	0	0	0

ZONAL LUMENS

Zone	Lumens
0	
0-10	65
10-20	184
20-30	265
30-40	293
40-50	270
50-60	213
60-70	143
70-80	73
80-90	18
90	

LUMINANCE DATA (cd/m<sup>2</sup>)

Vertical Angle	Horizontal Angles		
	0	45	90
45	8552	7697	6960
55	7344	6435	5672
65	6069	5280	4589
75	4673	4109	3545
85	3110	2871	2632

500 lm/ft

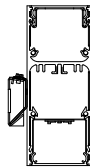

PHOTOMETRIC CURVE

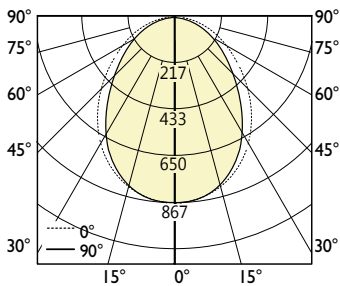

**Luminaire Lumens: 500 lm/ft**  
**Input Watts: 4.7 W/ft**  
**Efficacy: 106 lm/W**  
 IES FILE: TBWDLED-500-80-40-SO.IES

TESTED ACCORDING TO IES LM-79-2008

CANDELA DISTRIBUTION

Vertical Angle	Horizontal Angles				
	0	22.5	45	67.5	90
0	863	863	863	863	863
5	855	858	855	862	863
15	817	820	813	812	813
25	738	737	720	708	703
35	623	615	587	560	550
45	483	472	435	405	393
55	337	325	295	270	260
65	205	197	178	162	155
75	97	95	85	77	73
85	22	18	20	18	18
90	0	0	0	0	0

ZONAL LUMENS

Zone	Lumens
0	
0-10	81
10-20	229
20-30	331
30-40	367
40-50	337
50-60	266
60-70	178
70-80	92
80-90	23
90	

LUMINANCE DATA (cd/m<sup>2</sup>)

Vertical Angle	Horizontal Angles		
	0	45	90
45	10690	9620	8700
55	9180	8044	7089
65	7586	6599	5736
75	5841	5136	4431
85	3888	3589	3290

**i** All IES files for other lamping are available for download at: [www.axislighting.com](http://www.axislighting.com)

● PHOTOMETRIC DATA

750 lm/ft

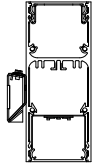

PHOTOMETRIC CURVE

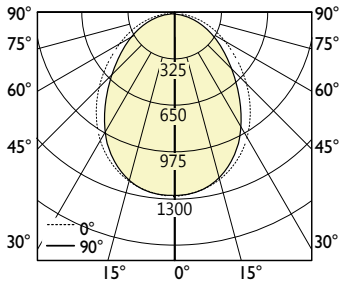

**Luminaire Lumens: 750 lm/ft**  
**Input Watts: 7.5 W/ft**  
**Efficacy: 100 lm/W**  
 IES FILE: TBWDLED-750-80-40-SO.IES

TESTED ACCORDING TO IES LM-79-2008

CANDELA DISTRIBUTION

Vertical Angle	Horizontal Angles				
	0	22.5	45	67.5	90
0	1295	1295	1295	1295	1295
5	1283	1288	1283	1293	1295
15	1225	1230	1220	1218	1220
25	1108	1105	1080	1063	1055
35	935	923	880	840	825
45	725	708	653	608	590
55	505	488	443	405	390
65	308	295	268	243	233
75	145	143	128	115	110
85	33	28	30	28	28
90	0	0	0	0	0

ZONAL LUMENS

Zone	Lumens
0	
0-10	122
10-20	344
20-30	497
30-40	550
40-50	506
50-60	399
60-70	268
70-80	138
80-90	34
90	

LUMINANCE DATA (cd/m<sup>2</sup>)

Vertical Angle	Horizontal Angles		
	0	45	90
45	16035	14432	13050
55	13770	12066	10634
65	11380	9899	8604
75	8762	7704	6647
85	5832	5383	4935

1000 lm/ft

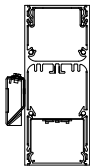

PHOTOMETRIC CURVE

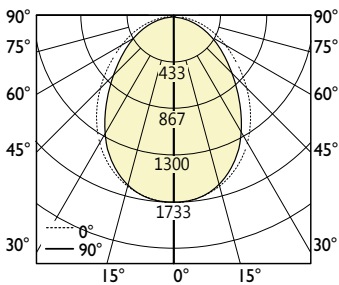

**Luminaire Lumens: 1000 lm/ft**  
**Input Watts: 10.5 W/ft**  
**Efficacy: 96 lm/W**  
 IES FILE: TBWDLED-80-40-SO.IES

TESTED ACCORDING TO IES LM-79-2008

CANDELA DISTRIBUTION

Vertical Angle	Horizontal Angles				
	0	22.5	45	67.5	90
0	1727	1727	1727	1727	1727
5	1710	1717	1710	1723	1727
15	1633	1640	1627	1623	1627
25	1477	1473	1440	1417	1407
35	1247	1230	1173	1120	1100
45	967	943	870	810	787
55	673	650	590	540	520
65	410	393	357	323	310
75	193	190	170	153	147
85	43	37	40	37	37
90	0	0	0	0	0

ZONAL LUMENS

Zone	Lumens
0	
0-10	163
10-20	459
20-30	663
30-40	733
40-50	675
50-60	533
60-70	357
70-80	183
80-90	46
90	

LUMINANCE DATA (cd/m<sup>2</sup>)

Vertical Angle	Horizontal Angles		
	0	45	90
45	21381	19243	17399
55	18360	16087	14179
65	15173	13199	11472
75	11683	10273	8863
85	7776	7178	6580

**i** All IES files for other lamping are available for download at: [www.axislighting.com](http://www.axislighting.com)