

● **PROJECT INFORMATION**

Project:

Type:

Notes:

● **DIMENSIONS**

SECTION VIEWS

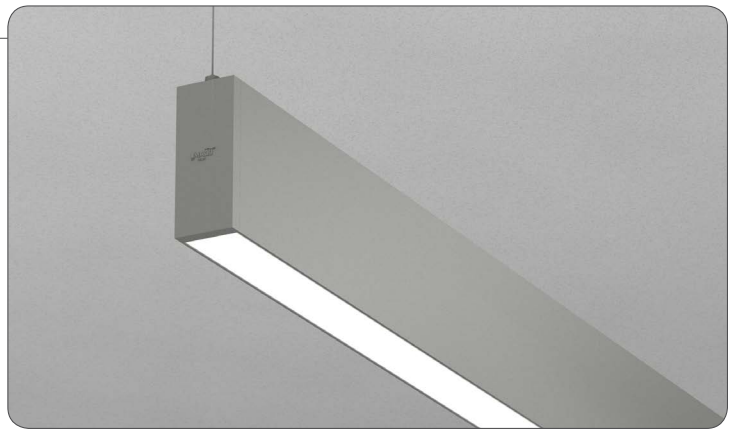
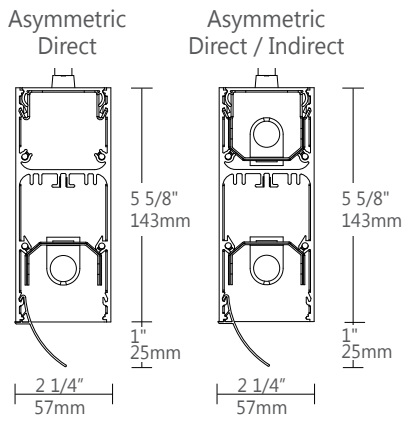

● **ORDERING CODE**

1	2	3	4	5	6	7	8	9	10	11	12	13	14	15	16
---	---	---	---	---	---	---	---	---	----	----	----	----	----	----	----

● **PRODUCT SPECIFICATIONS**

1 PRODUCT ID	2 OPTICS DIRECT	3 LENGTH/FT	4 SPECIFY LENGTH	5 LAMP	6 LAMP CONFIGURATION
<b>TB</b> pendant direct	<b>A</b> asymmetric	<b>2</b> 2' <b>3</b> 3' <b>4</b> 4' <b>5</b> 5' <b>6</b> 6' <b>8</b> 8' <b>12</b> 12' <b>S#</b> System Run	<b>NL</b> nominal (3' & 4' lamps) <b>NL4</b> nominal (4' lamps only) <b>EX</b> exact (3' & 4' lamps) <b>EX4</b> exact (4' lamps only)	<b>T5</b> T5 <b>T5HO</b> T5HO <b>T8</b> T8	<b>1D</b> 1 lamp down <b>2</b> 1 lamp up 1 lamp down <sup>(1)</sup>
for direct only				(1) Asymmetric only available for down lamp	

7 MR	8 FINISH	9 VOLTAGE	10 BALLAST	11 CIRCUITS	12 MOUNTING/SUSPENSION
<b>M11#</b> MR 11 halogen <b>M11LED#</b> MR 11 LED	<b>AP</b> aluminum paint <b>W</b> white <b>BLK</b> black <b>C</b> custom	<b>120</b> 120V <b>277</b> 277V <b>347</b> 347V <sup>(2)</sup> <b>UNV</b> universal	<b>D</b> dimming <b>E</b> instant start <sup>(3)</sup> <b>ERS</b> program start <b>BI</b> bi-level dimming	<b>1</b> 1 regular <b>2</b> 2 regular <b>2A/B</b> 2 alternating <b>+E(#)</b> emergency section <b>+NL(#)</b> night light section <b>+GTD(#)</b> generator transfer device <b>+M</b> MR	<b>SA#</b> drywall+stem length >48" (18" std.)
Add 6" per lamp Requires 120V or 277V		(2) Please consult factory	(3) Available with T8 lamp only		

13 BATTERY (OPTIONAL)	14 OTHER (OPTIONAL)	15 IC CONTROLS (OPTIONAL)	16 CUSTOM (OPTIONAL)
<b>B#</b> battery pack 4' sections	<b>D</b> dust cover <b>F</b> fuse	<b>DS#</b> daylight sensor <b>OS#</b> occupancy sensor <b>DS+OS#</b> daylight+occupancy sensor <b>DOS#</b> daylight&occupancy sensor	<b>C</b> custom
Requires 120V or 277V		See integrated controls guide for further details	Please specify

## CONSTRUCTION

<b>Housing</b>	Extruded Aluminum (0.075" nominal) up to 70% Recycled Content
<b>End Cap</b>	Sheet Steel (18 ga)
<b>Interior Brackets</b>	Die Formed Sheet Steel (20 gauge)
<b>Reflectors</b>	White Powder Coated Sheet Steel (22 ga)
<b>Suspension</b>	Ø 1/2" Stem

## WEIGHT

<b>4 ft</b>	13.2 lbs / 6.0 kg
<b>8 ft</b>	26.4 lbs / 12.0 Kg
<b>12 ft</b>	39.6 lbs / 18.0 Kg

## SYSTEM (S#)

TWIN BEAM 2 linear systems, with the use of a strong profile, allow for a nearly hair thin connection system of continuous runs. Lengths of 4', 8', 12' as well as custom lengths are available. Runs of TWIN BEAM 2 that are greater than 12' in length are designated as systems (S#). This means that the run is comprised of a combination of 4', 8' and/or 12' sections to be assembled on site using our joining system. For more information on systems and joining, please refer to the BEAM installation sheets available for download at [www.axislighting.com](http://www.axislighting.com).

## ELECTRICAL

<b>Ballast</b>	Electronic IS, Electronic Rapid Start, Dimming (0-10V, Line, EcoSystem, DALI), BI-level dimming With preinstalled ballast disconnect as per NEC & CEC
<b>Emergency</b>	Emergency battery pack or emergency circuit
<b>Voltage</b>	120V, 277V, 347V, UNV

**i** Incorporating these components may have limitations or effect the length of the luminaire, please contact factory for more details.

## FINISH

Aluminium paint, Powder Coated and custom finishes are also available.

## OPTICS

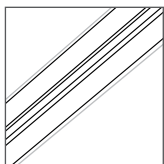

A asymmetric

**ASYMMETRIC NO LENS**  
(asymmetric reflector)

## ASYMMETRIC

### Outer Asymmetric Reflector

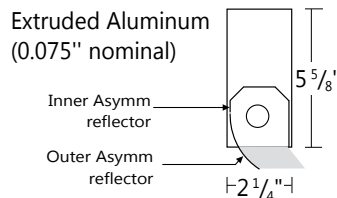

## JOINERS

In order to allow very long runs of TWIN BEAM 2 luminaires, Axis has developed an effective joining system. Special care has been taken to maximize the performance of the joiner for each BEAM option.

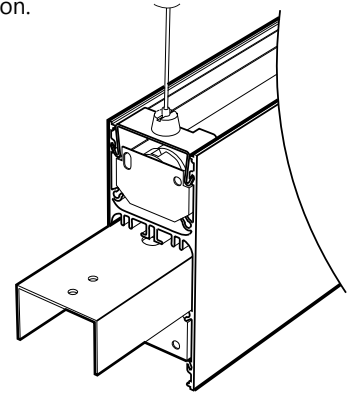

**NOTE:** Hang each system segment individually. Do not assemble system prior to mounting.

## MR11

<b>Blank</b>	Extruded Aluminum (0.075" nominal)
<b>MR11 Halogens</b>	1.4" diameter (20W / 35W)
<b>MR11 LED</b>	1.4" diameter
<b>Quantity</b>	For every 4' fluorescent lamp section, there may be up to a maximum of 4 x MR11 lamps.

### Spacing

Each MR11 is placed centered on a blank section 6" in length.

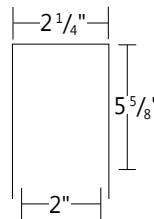

For a series of MR11's within a given section length, they will be spaced evenly on a longer blank section. The directed light of MR11 Halogen lamps are fixed downward. Custom spacing may be available on special request. \*Please consult factory

### Between fluorescent lamps sections

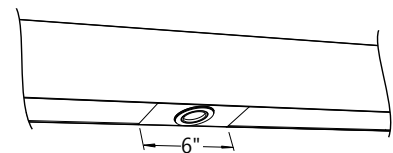

### At luminaire ends

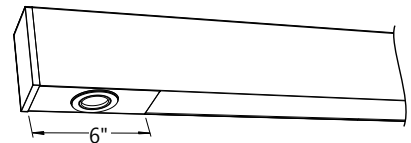

### Several in a long blank section

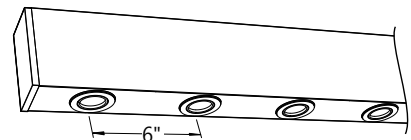

## APPROVALS

Certified to UL and CUL standards   
 Meets NYC requirements  
 Suitable for damp locations.

● **MOUNTING SPACING END TO END**

<b>T5/T5HO LAMP</b>	4'	(46 <sup>5</sup> / <sub>16</sub> " C.C.)
	8'	(92 <sup>5</sup> / <sub>8</sub> " C.C.)
	12'	(138 <sup>15</sup> / <sub>16</sub> " C.C.)

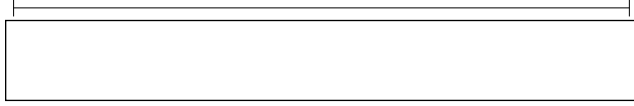

<b>T8 LAMP</b>	4'	(48" C.C.)
	8'	(96" C.C.)
	12'	(144" C.C.)



● **MOUNTING SPACING STAGGERED**

<b>T5/T5HO I LAMP</b>	8' 3X3'	(95 <sup>1</sup> / <sub>2</sub> " C.C.)
	8' 2X4'	(88 <sup>5</sup> / <sub>8</sub> " C.C.)
	12' 3X4'	(130 <sup>15</sup> / <sub>16</sub> " C.C.)
	12' 2X4'+2X3'	(149 <sup>5</sup> / <sub>8</sub> " C.C.)

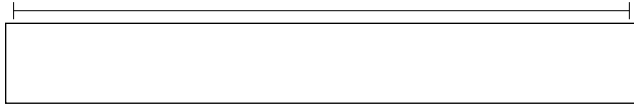

**i** Row configuration and mounting spacing file is available for download at: [www.axislighting.com](http://www.axislighting.com)

● **OTHER MOUNTING OPTIONS**

TWIN BEAM 2 is also available with pendant, wall and vertical wall mounted options.

**i** Specification sheets and Installation sheets for all mounting for BEAM luminaires are available for download at [www.axislighting.com](http://www.axislighting.com)

● **MOUNTING OPTIONS**

**CT TILE CEILING - ON GRID**

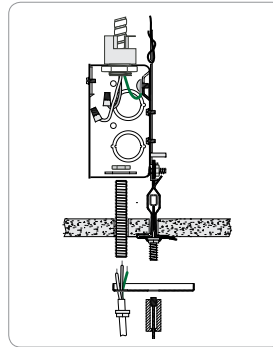

Power feed

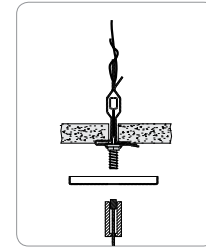

Non power feed

**CA DRYWALL CEILING**

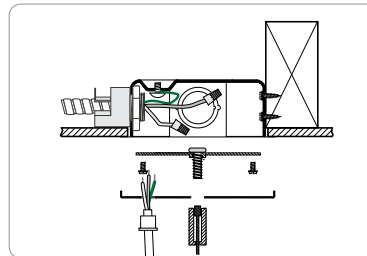

Power feed

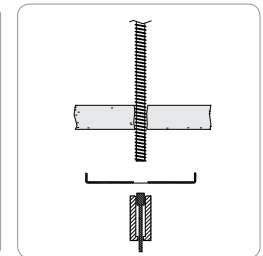

Non power feed

**SA STEM MOUNT IN DRYWALL CEILING**

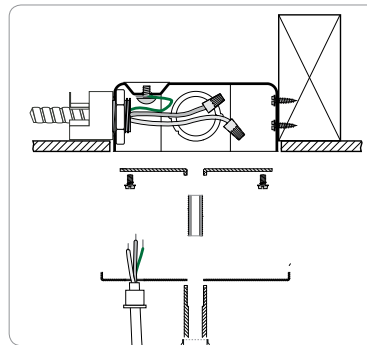

Power feed

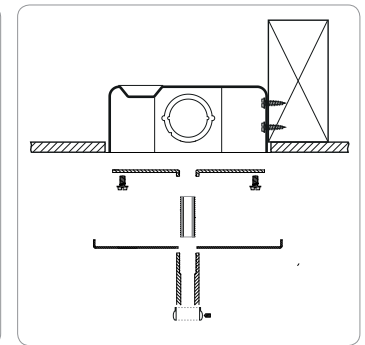

Non power feed

## ● INTEGRATED CONTROL OPTIONS

TWIN BEAM 2 luminaires allow the use of integrated controls such as daylight sensors (DS), occupancy sensors (OS) and combination daylight/occupancy sensors (DOS). These options can be seamlessly integrated into our luminaires. The control system could be used to optimize the lighting of the space by reducing energy consumption through daylight harvesting and occupancy, thereby improving the overall interior environment and allowing for LEED credits.

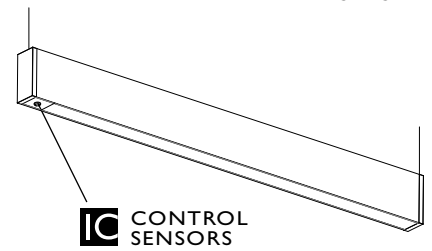

- Consult factory for other options.

SENSORS	BRAND	Model	TYPE	CODE	COMPATIBLE DIMMING BALLAST
Daylight Sensor (DS)	Lutron	EC-DIR-WH	Daylight	LD	EcoSystem
	Wattstopper	FD-301	Daylight	WD	0-10V
	Philips	Luxsense	Daylight	PL	0-10V
Occupancy Sensor (OS)	Wattstopper	FS-205	PIR Occupancy	WP1	Programmed Rapid Start
		FS-355	PIR Occupancy	WP2	Programmed Rapid Start
		FM-105	High Frequency Occupancy	WH	Programmed Rapid Start
Daylight & Occupancy Sensors (DOS)	Philips	Actilume	Daylight & PIR Occupancy	PA	DALI or 0-10V

**i** All IES files for other lamping are available for download at: [www.axislighting.com](http://www.axislighting.com)