

PROJECT INFORMATION

Project:

Type:

Notes:

DIMENSIONS

SECTION VIEWS

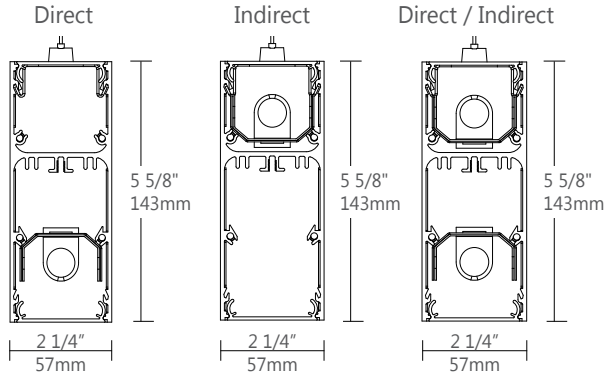

ORDERING CODE

1	2	3	4	5	6	7	8	9	10	11	12	13	14	15	16
---	---	---	---	---	---	---	---	---	----	----	----	----	----	----	----

PRODUCT SPECIFICATIONS

1 PRODUCT ID	2 OPTICS DIRECT	3 LENGTH/FT	4 SPECIFY LENGTH	5 LAMP	6 LAMP CONFIGURATION
TB pendant	S satin lens F frosted lens PL semi spec. para. louvers B blank	2 2' 3 3' 4 4' 5 5' 6 6' 8 8' 12 12' S# System Run	NL nominal (3' & 4' lamps) NL4 nominal (4' lamps only) EX exact (3' & 4' lamps) EX4 exact (4' lamps only)	T5 T5 T5HO T5HO T8 T8	0 0 lamp 1U 1 lamp up 1D 1 lamp down 2 1 lamp up 1 lamp down +S staggered ⁽¹⁾
for direct only					(1) Not available for T8 lamp

7 MR	8 FINISH	9 VOLTAGE	10 BALLAST	11 CIRCUITS
M11# MR 11 halogen M11LED# MR 11 LED	AP aluminum paint W white BLK black C custom	120 120V 277 277V 347 347V ⁽²⁾ UNV universal	D dimming E instant start ⁽³⁾ ERS program start BI bi-level dimming	1 1 regular 2 2 regular 2A/B 2 alternating +E(#) emergency section +NL(#) night light section +GTD(#) generator transfer device +M MR
Add 6" per lamp Requires 120V or 277V		(2) Please consult factory	(3) Available with T8 lamp only	

12 MOUNTING/SUSPENSION	13 BATTERY (OPTIONAL)	14 OTHER (OPTIONAL)	15 IC CONTROLS (OPTIONAL)	16 CUSTOM (OPTIONAL)
CA# drywall+cable length (36" std.) CT9-# TB/TG 9/16+cable length (36" std.) CT15-# TB/TG15/16+cable length (36" std.) CTS# ST+cable length (36" std.) SA# drywall+stem length >48" (18" std.)	B# battery pack 4' sections	D dust cover F fuse	DS# daylight sensor OS# occupancy sensor DS+OS# daylight+occupancy sensor DOS# daylight&occupancy sensor	C custom
See ceiling mounting guide for further details	Requires 120V or 277V		See integrated controls guide for further details	Please specify

● CONSTRUCTION

Housing	Extruded Aluminum (0.075" nominal) up to 70% Recycled Content
End Cap	Sheet Steel (18 ga)
Interior Brackets	Die Formed Sheet Steel (20 gauge)
Reflectors	White Powder Coated Sheet Steel (22 ga)
Louvers	Die Formed Semi-Specular Aluminum (22 ga)
Lenses	Extruded Acrylic (0.070" nominal) Satin: 68% trans. Frosted: 85% trans.
Hanger	Die Formed Sheet Steel (16 gauge)
Suspension	Aircraft Cable or Ø 1/2" Stem
Cable Grips	Quick Connecting / Release

● WEIGHT

4 ft	13.2 lbs / 6.0 kg
8 ft	26.4 lbs / 12.0 kg
12 ft	39.6 lbs / 18.0 kg

● SYSTEM (S#)

TWIN BEAM 2 linear systems, with the use of a strong profile, allow for a nearly hair thin connection system of continuous runs. Lengths of 4', 8', 12' as well as custom lengths are available. Runs of TWIN BEAM 2 that are greater than 12' in length are designated as systems (S#). This means that the run is comprised of a combination of 4', 8' and/or 12' sections to be assembled on site using our joining system. For more information on systems and joining, please refer to the BEAM installation sheets available for download at www.axislighting.com.

● ELECTRICAL

Ballast Electronic IS, Electronic Rapid Start, Dimming (0-10V, Line, EcoSystem, DALI), BI-level dimming
With preinstalled ballast disconnect as per NEC & CEC

Emergency Emergency battery pack or emergency circuit

Voltage 120V, 277V, 347V, UNV

i Incorporating these components may have limitations or effect the length of the luminaire, please contact factory for more details.

● FINISH

Aluminium paint, Powder Coated and custom finishes are also available.

● APPROVALS

Certified to UL and CUL standards
 Meets NYC requirements
 Suitable for damp locations.

● JOINERS

In order to allow very long runs of TWIN BEAM 2 luminaires, Axis has developed an effective joining system. Special care has been taken to maximize the performance of the joiner for each BEAM option.

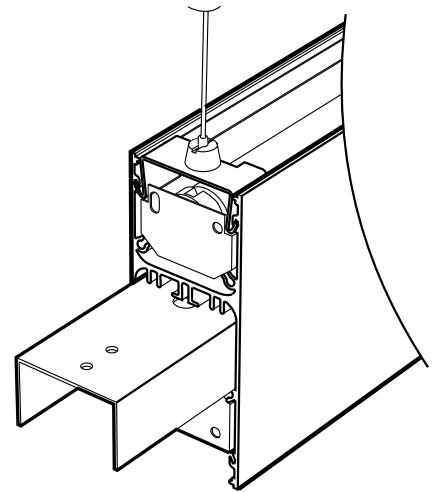

NOTE: Hang each system segment individually. Do not assemble system prior to mounting.

● STAGGERED LAMPING

When TWIN BEAM 2 is used in continuous runs longer than 4', staggered lamping can be used to eliminate the appearance of socket shadows at the ends of the lamps. TWIN BEAM 2 uses a staggered overlap of bracket lengths (4"), along with 3' and 4' lamps, allowing us to match almost any row length requirements with optimal results. For example 3 x 3' staggered T5 lamps can be used to completely illuminate the lens of an 8' nominal luminaire.

LAMP TYPE	T5	T5HO
1 lamp	•	•

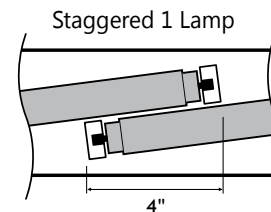

● **OPTICS**



S satin lens

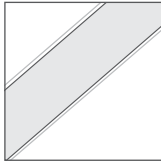

F frosted lens

SATIN & FROSTED LENS
 (acrylic snap-in lens)
 satin: 68% trans.
 frosted: 85% trans.

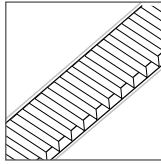

PL semi-specular parabolic louvers

LOUVERS
 (semi-spec. parabolic louver)
 9/16" deep blades – 5/8" spacing
 72 blades per 4'

● **CORNERS**

Unlit Corners - TWIN

Beam2 features a multitude of layout patterns with the use of a number of corners, 90° corner, T or X junctions.

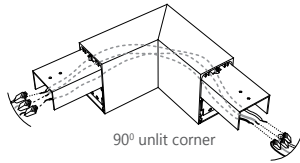

90° unlit corner

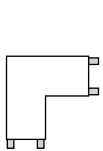

90° corner

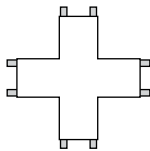

X junction

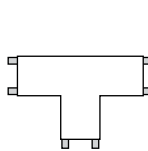

T junction

i For custom corner angles, please consult factory. Specifications sheets for all corners are available at: www.axislighting.com

● **MR11**

Blank MR11 Halogens MR11 LED Quantity

Extruded Aluminum (0.075" nominal)
 1.4" diameter (20W / 35W)
 1.4" diameter

For every 4' fluorescent lamp section, there may be up to a maximum of 4 x MR11 lamps.

Spacing

Each MR11 is placed centered on a blank section 6" in length.

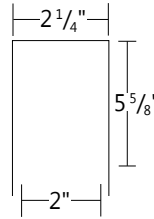

For a series of MR11's within a given section length, they will be spaced evenly on a longer blank section. The directed light of MR11 Halogen lamps are fixed downward. Custom spacing may be available on special request. *Please consult factory

Between fluorescent lamps sections

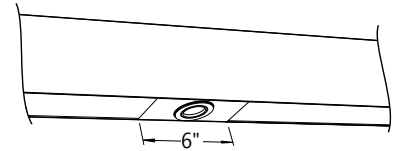

At luminaire ends

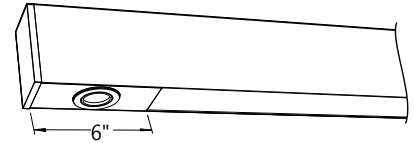

Several in a long blank section

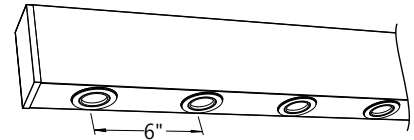

● **MOUNTING SPACING END TO END**

T5/T5HO LAMP	4'	(46 ⁵ / ₁₆ " C.C.)
	8'	(92 ⁵ / ₈ " C.C.)
	12'	(138 ¹⁵ / ₁₆ " C.C.)

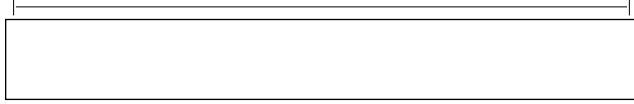

T8 LAMP	4'	(48" C.C.)
	8'	(96" C.C.)
	12'	(144" C.C.)

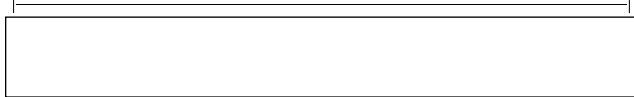

● **MOUNTING SPACING STAGGERED**

T5/T5HO I LAMP	8' 3X3'	(95 ¹ / ₂ " C.C.)
	8' 2X4'	(88 ⁵ / ₈ " C.C.)
	12' 3X4'	(130 ¹⁵ / ₁₆ " C.C.)
	12' 2X4'+2X3'	(149 ⁵ / ₈ " C.C.)

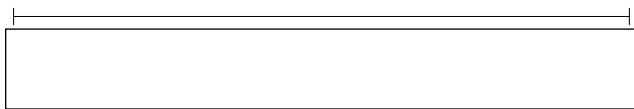

i Row configuration and mounting spacing file is available for download at: www.axislighting.com

● **OTHER MOUNTING OPTIONS**

TWIN BEAM 2 is also available with wall and vertical wall mounted options.

i Specification sheets and Installation sheets for all mounting for BEAM luminaires are available for download at www.axislighting.com

● **MOUNTING OPTIONS**

CT TILE CEILING - ON GRID

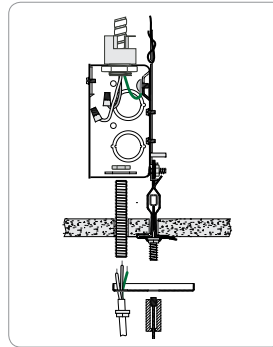

Power feed

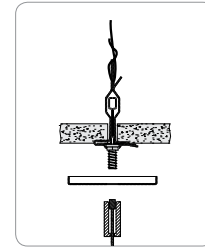

Non power feed

CA DRYWALL CEILING

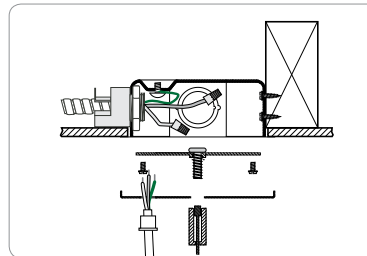

Power feed

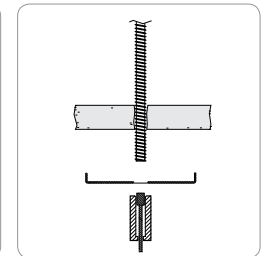

Non power feed

SA STEM MOUNT IN DRYWALL CEILING

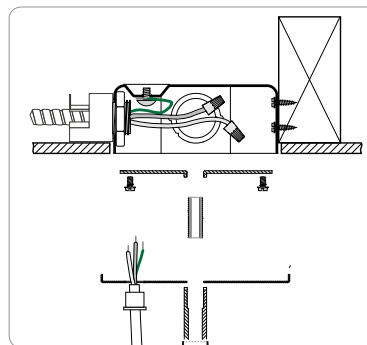

Power feed

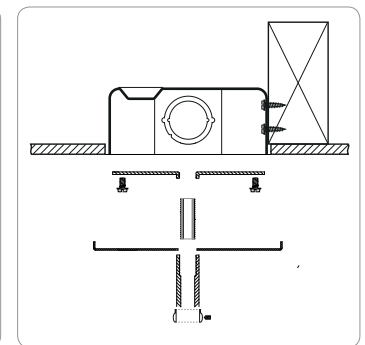

Non power feed

● INTEGRATED CONTROL OPTIONS

TWIN BEAM 2 luminaires allow the use of integrated controls such as daylight sensors (DS), occupancy sensors (OS) and combination daylight/occupancy sensors (DOS). These options can be seamlessly integrated into our luminaires. The control system could be used to optimize the lighting of the space by reducing energy consumption through daylight harvesting and occupancy, thereby improving the overall interior environment and allowing for LEED credits.

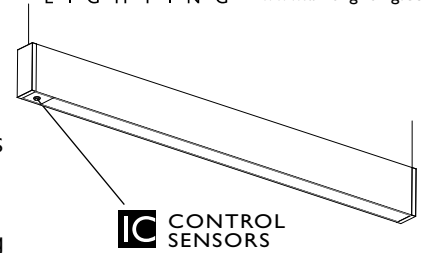

- Consult factory for other options.

SENSORS	BRAND	Model	TYPE	CODE	COMPATIBLE DIMMING BALLAST
Daylight Sensor (DS)	Lutron	EC-DIR-WH	Daylight	LD	EcoSystem
	Wattstopper	FD-301	Daylight	WD	0-10V
	Philips	Luxsense	Daylight	PL	0-10V
Occupancy Sensor (OS)	Wattstopper	FS-205	PIR Occupancy	WP1	Programmed Rapid Start
		FS-355	PIR Occupancy	WP2	Programmed Rapid Start
		FM-105	High Frequency Occupancy	WH	Programmed Rapid Start
Daylight & Occupancy Sensors (DOS)	Philips	Actilume	Daylight & PIR Occupancy	PA	DALI or 0-10V

● PHOTOMETRIC DATA

I T5



PHOTOMETRIC CURVE

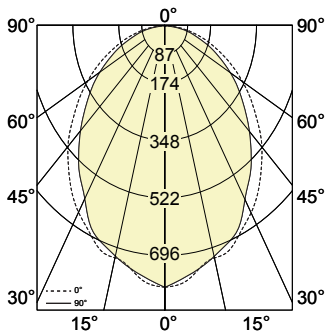

Test Lamp: 1xF28T5
IES FILE: TB-F-4-T5-1D

Efficiency: 55.6%

CANDELA DISTRIBUTION

Vertical Angle	Horizontal Angles					Zonal Lumens
	0	22.5	45	67.5	90	
0	783	783	783	783	783	
5	765	758	746	743	753	41
15	705	699	691	687	684	167
25	614	605	584	572	568	257
35	504	496	474	454	448	296
45	387	376	356	338	332	285
55	278	266	252	238	234	241
65	178	171	159	149	146	177
75	96	93	85	75	76	107
85	30	26	20	16	15	40
90	2	1	0	0	0	

LUMINANCE DATA (CD/M²)

Vertical Angle	Horizontal Angles		
	0	45	90
45	7049	2559	1946
55	5974	1748	1295
65	4837	1102	791
75	3707	601	414
85	2134	150	86

COEFFICIENTS OF UTILIZATION (%)

Ceiling	80			70			50				
	70	50	30	10	70	50	30	10	50	30	10
Wall	70	50	30	10	70	50	30	10	50	30	10
0	66	66	66	66	65	65	65	65	62	62	62
1	61	59	56	54	60	57	55	53	55	53	52
2	56	52	48	45	54	51	47	45	49	46	44
3	51	46	42	38	50	45	41	38	43	40	37
4	47	41	36	33	46	40	36	33	39	35	32
5	44	37	32	29	43	36	32	28	35	31	28
6	41	33	29	25	39	33	28	25	32	28	25
7	38	31	26	23	37	30	26	23	29	25	22
8	35	28	23	20	34	28	23	20	27	23	20
9	33	26	21	18	32	26	21	18	25	21	18
10	31	24	20	17	30	24	20	17	23	19	17

Based on floor reflectance of 20

i All IES files for other lamping are available for download at: www.axislighting.com

● **PHOTOMETRIC DATA**

1 T5



PHOTOMETRIC CURVE

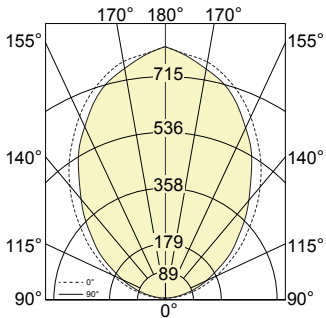

Test Lamp: 1xF28T5

IES FILE: TB-F-4-T5-1U

Efficiency: 59.4%

CANDELA DISTRIBUTION

Vertical Angle	Horizontal Angles					Zonal Lumens
	0	22.5	45	67.5	90	
90	2	1	0	0	0	
95	33	28	23	18	18	13
105	106	98	92	84	82	80
115	193	188	174	167	158	155
125	297	290	270	258	258	228
135	413	401	380	366	362	286
145	533	522	506	488	479	315
155	644	633	623	614	606	300
165	736	729	723	718	713	230
175	783	791	771	781	778	109
180	805	805	805	805	805	

COEFFICIENTS OF UTILIZATION (%)

Ceiling	80			70			50				
	70	50	30	10	70	50	30	10	50	30	10
Wall	70	50	30	10	70	50	30	10	50	30	10
0	0	57	57	57	57	48	48	48	48	33	33
1	1	52	49	47	45	44	42	40	39	29	28
2	2	47	43	40	37	40	37	34	32	25	24
3	3	43	38	34	31	36	32	29	26	22	20
4	4	39	33	29	26	33	28	25	22	20	17
5	5	36	29	25	22	30	25	22	19	17	15
6	6	33	26	22	19	28	22	19	16	15	13
7	7	30	23	19	16	25	20	16	14	14	12
8	8	28	21	17	14	24	18	14	12	12	10
9	9	26	19	15	12	22	16	13	11	11	9
10	10	24	17	13	11	20	15	11	9	10	8

Based on floor reflectance of 20

2 T5



PHOTOMETRIC CURVE

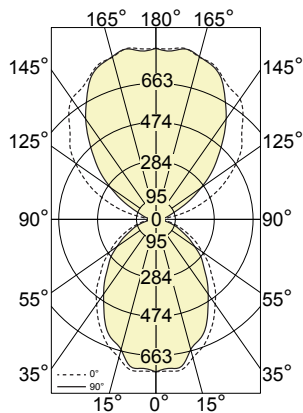

Test Lamp: 2xF28T5

IES FILE: TB-F-4-T5-2

Efficiency: 64.7%

CANDELA DISTRIBUTION

Vertical Angle	Horizontal Angles					Zonal Lumens
	0	22.5	45	67.5	90	
0	743	743	743	743	743	
5	742	745	764	737	729	40
15	698	698	689	693	657	167
25	616	606	586	569	577	258
35	504	492	476	459	445	297
45	385	376	352	339	331	285
55	276	266	250	241	232	242
65	180	173	162	150	140	178
75	96	93	82	77	74	107
85	29	26	20	16	15	40
90	3	2	1	1	1	
95	27	22	21	18	18	12
105	172	118	72	69	64	79
115	333	281	192	144	132	180
125	480	446	347	291	270	300
135	592	590	517	453	427	387
145	715	706	672	616	597	417
155	767	779	781	759	756	375
165	818	817	825	826	821	267
175	834	853	832	834	823	120
180	833	833	833	833	833	

COEFFICIENTS OF UTILIZATION (%)

Ceiling	80				70				50			
	70	50	30	10	70	50	30	10	50	30	10	
Wall	70	50	30	10	70	50	30	10	50	30	10	
0	68	68	68	68	62	62	62	62	51	51	51	
1	63	60	57	55	57	55	53	51	45	44	43	
2	57	52	49	45	52	48	45	42	40	38	36	
3	52	46	42	38	48	42	39	35	35	32	30	
4	48	41	36	32	44	38	33	30	32	28	26	
5	44	37	32	28	40	34	29	26	28	25	22	
6	41	33	28	24	37	30	26	23	26	22	20	
7	37	30	25	21	34	27	23	20	23	20	17	
8	35	27	22	19	32	25	21	18	21	18	15	
9	32	25	20	17	30	23	19	16	19	16	14	
10	30	23	18	15	28	21	17	14	18	15	12	

Based on floor reflectance of 20

LUMINANCE DATA (CD/M²)

Vertical Angle	Horizontal Angles		
	0	45	90
45	7017	2535	1942
55	5937	1738	1284
65	4890	1124	757
75	3712	583	401
85	2064	152	85

i All IES files for other lamping are available for download at: www.axislighting.com

● **PHOTOMETRIC DATA**

1 T5HO



PHOTOMETRIC CURVE

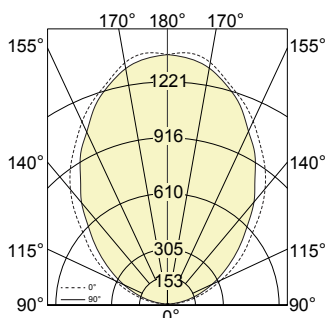

Test Lamp: 1x F54T5HO
 IES FILE: TB-F-4-T5HO-1U

Efficiency: 59.4%

CANDELA DISTRIBUTION

Vertical Angle	Horizontal Angles					Zonal Lumens
	0	22.5	45	67.5	90	
90	3	2	1	0	0	
100	117	110	96	87	84	23
110	252	241	224	210	208	138
120	424	408	383	362	352	266
130	600	590	561	539	523	395
140	825	794	759	728	731	494
150	1006	995	971	951	948	543
160	1183	1196	1168	1159	1152	515
170	1337	1315	1315	1304	1305	397
175	1374	1354	1341	1341	1344	189
180	1360	1360	1360	1360	1360	

COEFFICIENTS OF UTILIZATION (%)

Ceiling	80			70			50				
	70	50	30	10	70	50	30	10	50	30	10
Wall	70	50	30	10	70	50	30	10	50	30	10
0	57	57	57	57	48	48	48	48	33	33	33
1	52	49	47	45	44	42	40	39	29	28	27
2	47	43	40	37	40	37	34	32	25	24	22
3	43	38	34	30	36	32	29	26	22	20	19
4	39	33	29	26	33	28	25	22	20	17	16
5	36	29	25	22	30	25	22	19	17	15	13
6	33	26	22	18	28	22	19	16	15	13	11
7	30	23	19	16	25	20	16	14	14	12	10
8	28	21	17	14	23	18	14	12	12	10	9
9	26	19	15	12	22	16	13	11	11	9	7
10	24	17	13	11	20	15	11	9	10	8	7

Based on floor reflectance of 20

2 T5HO

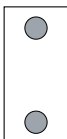

PHOTOMETRIC CURVE

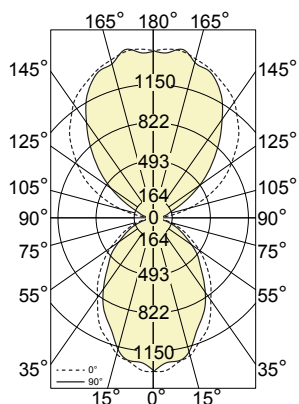

Test Lamp: 2x F54T5HO
 IES FILE: TB-F-4-T5HO-2

Efficiency: 64.7%

CANDELA DISTRIBUTION

Vertical Angle	Horizontal Angles					Zonal Lumens
	0	22.5	45	67.5	90	
0	1321	1321	1321	1321	1321	
5	1316	1284	1283	1286	1251	69
15	1224	1212	1225	1169	1189	290
25	1076	1041	1012	1002	969	444
35	860	850	809	789	775	510
45	671	641	613	585	564	490
55	481	462	423	412	400	416
65	305	301	280	258	252	306
75	167	159	147	131	130	186
85	50	46	35	27	26	69
90	5	3	1	1	1	
95	46	37	34	32	28	20
105	297	205	127	117	116	137
115	577	481	330	248	224	310
125	816	777	600	505	469	518
135	1039	1016	892	770	741	666
145	1218	1204	1154	1071	1028	717
155	1331	1339	1323	1314	1291	648
165	1421	1397	1418	1418	1388	459
175	1466	1437	1458	1471	1436	208
180	1445	1445	1445	1445	1445	

COEFFICIENTS OF UTILIZATION (%)

Ceiling	80				70				50			
	70	50	30	10	70	50	30	10	50	30	10	
Wall	70	50	30	10	70	50	30	10	50	30	10	
0	68	68	68	68	62	62	62	62	51	51	51	
1	63	60	57	55	57	55	53	51	45	44	43	
2	57	52	49	45	52	48	45	42	40	38	36	
3	52	46	42	38	48	42	39	35	35	32	30	
4	48	41	36	32	44	38	33	30	32	28	26	
5	44	37	32	28	40	34	29	26	28	25	22	
6	41	33	28	24	37	30	26	23	26	22	20	
7	37	30	25	21	34	27	23	20	23	20	17	
8	35	27	22	19	32	25	21	18	21	18	15	
9	32	25	20	17	30	23	19	16	19	16	14	
10	30	23	18	15	28	21	17	14	18	15	12	

Based on floor reflectance of 20

LUMINANCE DATA (CD/M²)

Vertical Angle	Horizontal Angles		
	0	45	90
45	12236	4414	3311
55	10351	2937	2215
65	8287	1937	1363
75	6468	1044	709
85	3511	260	145

i All IES files for other lamping are available for download at: www.axislighting.com

● **PHOTOMETRIC DATA**

I T5HO



PHOTOMETRIC CURVE

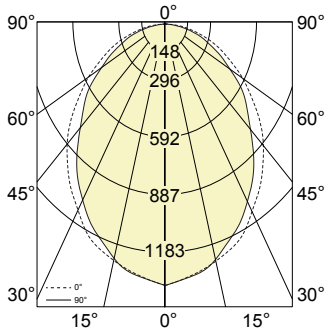

Test Lamp: IxF54T5HO
IES FILE: TB-F-4-T5HO-1D

Efficiency: 55.8%

CANDELA DISTRIBUTION

Vertical Angle	Horizontal Angles					Zonal Lumens
	0	22.5	45	67.5	90	
0	1331	1331	1331	1331	1331	
5	1253	1254	1237	1249	1257	69
15	1145	1142	1108	1096	1091	288
25	961	949	929	898	892	446
35	774	753	714	683	667	512
45	568	551	527	503	501	494
55	387	376	359	335	326	418
65	238	228	208	193	194	308
75	106	101	90	81	77	187
85	52	44	34	29	26	69
90	3	2	0	0	0	

COEFFICIENTS OF UTILIZATION (%)

Ceiling	80			70			50				
	70	50	30	10	70	50	30	10	50	30	10
Wall	70	50	30	10	70	50	30	10	50	30	10
0	67	67	67	67	65	65	65	65	62	62	62
1	61	59	57	55	60	58	56	54	55	54	52
2	56	52	48	45	55	51	47	45	49	46	44
3	52	46	42	38	50	45	41	38	43	40	37
4	47	41	36	33	46	40	36	33	39	35	32
5	44	37	32	29	43	36	32	29	35	31	28
6	41	34	29	25	40	33	29	25	32	28	25
7	38	31	26	23	37	30	26	23	29	25	22
8	35	28	24	20	35	28	23	20	27	23	20
9	33	26	22	19	32	26	21	18	25	21	18
10	31	24	20	17	30	24	20	17	23	19	17

Based on floor reflectance of 20

LUMINANCE DATA (CD/M²)

Vertical Angle	Horizontal Angles		
	0	45	90
45	12262	4437	3418
55	10304	3022	2221
65	8481	1935	1354
75	6362	1027	722
85	3617	259	149

COEFFICIENTS OF UTILIZATION (%)

Ceiling	80			70			50				
	70	50	30	10	70	50	30	10	50	30	10
Wall	70	50	30	10	70	50	30	10	50	30	10
0	59	59	59	59	58	58	58	58	56	56	56
1	55	53	51	49	53	51	50	48	49	48	46
2	50	46	43	40	49	45	42	40	44	41	39
3	46	41	37	34	45	40	37	34	39	36	33
4	42	37	33	29	41	36	32	29	35	31	29
5	39	33	29	26	38	32	28	25	31	28	25
6	36	30	26	23	35	30	25	23	29	25	22
7	34	27	23	20	33	27	23	20	26	23	20
8	32	25	21	18	31	25	21	18	24	21	18
9	30	23	19	17	29	23	19	16	22	19	16
10	28	21	18	15	27	21	18	15	21	17	15

Based on floor reflectance of 20

I T8



PHOTOMETRIC CURVE

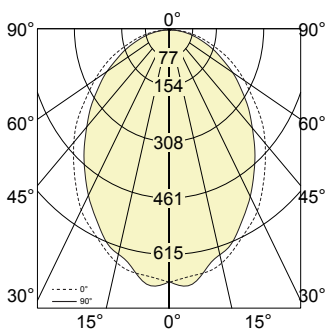

Test Lamp: IxF32T8
IES FILE: TB-F-4-T8-1D

Efficiency: 49.8%

CANDELA DISTRIBUTION

Vertical Angle	Horizontal Angles					Zonal Lumens
	0	22.5	45	67.5	90	
0	684	684	684	684	684	
5	660	654	658	638	640	36
15	588	583	579	569	560	149
25	500	494	477	461	454	230
35	400	389	372	351	346	265
45	295	288	269	256	252	255
55	208	198	185	172	167	216
65	122	118	107	99	97	161
75	57	52	47	43	42	97
85	25	24	18	15	14	36
90	2	1	0	0	0	

LUMINANCE DATA (CD/M²)

Vertical Angle	Horizontal Angles		
	0	45	90
45	6163	2203	1696
55	5166	1503	1127
65	4355	965	688
75	3295	518	358
85	1738	129	74

i All IES files for other lamping are available for download at: www.axislighting.com

● **PHOTOMETRIC DATA**

1 T8



PHOTOMETRIC CURVE

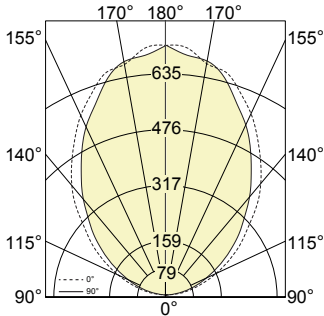

Test Lamp: 1xF32T8

IES FILE: TB-F-4-T8-1U

Efficiency: 52.5%

CANDELA DISTRIBUTION

Vertical Angle	Horizontal Angles					Zonal Lumens
	0	22.5	45	67.5	90	
0	2	1	0	0	0	
5	29	25	20	15	15	11
15	90	88	81	75	73	71
25	170	163	153	143	139	136
35	262	252	236	228	224	201
45	368	357	338	325	317	253
55	470	461	442	433	423	279
65	573	567	552	542	537	266
75	660	637	644	636	643	204
85	709	703	687	686	688	98
90	714	714	714	714	714	

COEFFICIENTS OF UTILIZATION (%)

Ceiling	80			70			50				
	70	50	30	10	70	50	30	10	50	30	10
Wall	70	50	30	10	70	50	30	10	50	30	10
0	50	50	50	50	43	43	43	43	29	29	29
1	46	43	42	40	39	37	36	34	25	25	24
2	41	38	35	33	35	32	30	28	22	21	20
3	38	33	30	27	32	28	26	23	20	18	16
4	34	29	25	23	29	25	22	20	17	15	14
5	31	26	22	19	27	22	19	17	15	13	12
6	29	23	19	16	24	20	17	14	14	12	10
7	26	21	17	14	23	18	15	12	12	10	9
8	24	18	15	12	21	16	13	11	11	9	8
9	23	17	13	11	19	14	11	9	10	8	7
10	21	15	12	9	18	13	10	8	9	7	6

Based on floor reflectance of 20

2 T8



PHOTOMETRIC CURVE

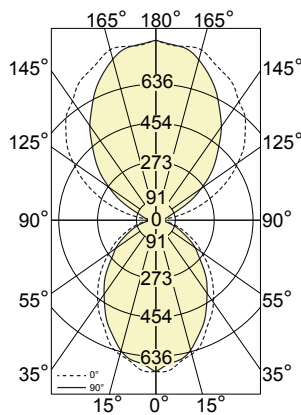

Test Lamp: 2xF32T8

IES FILE: TB-F-4-T8-2

Efficiency: 58.2%

CANDELA DISTRIBUTION

Vertical Angle	Horizontal Angles					Zonal Lumens
	0	22.5	45	67.5	90	
0	689	689	689	689	689	
5	687	663	682	680	657	36
15	631	626	612	615	610	150
25	543	541	535	507	513	230
35	453	443	425	403	403	265
45	353	340	319	305	300	256
55	250	241	227	215	214	217
65	162	156	145	136	129	161
75	87	81	79	70	67	97
85	27	23	18	15	14	36
90	3	2	1	1	0	
95	24	19	18	15	15	10
105	159	109	61	57	56	70
115	310	240	176	132	117	161
125	453	384	305	267	249	270
135	573	518	443	401	381	344
145	657	644	571	531	516	368
155	735	732	688	644	645	335
165	801	785	766	763	754	248
175	799	805	790	817	803	114
180	818	818	818	818	818	

COEFFICIENTS OF UTILIZATION (%)

Ceiling	80				70				50			
	70	50	30	10	70	50	30	10	50	30	10	
Wall	70	50	30	10	70	50	30	10	50	30	10	
0	61	61	61	61	56	56	56	56	46	46	46	
1	56	54	52	50	51	49	47	46	41	39	38	
2	51	47	44	41	47	43	40	38	36	34	32	
3	47	42	37	34	43	38	35	32	32	29	27	
4	43	37	32	29	39	34	30	27	28	25	23	
5	39	33	28	25	36	30	26	23	25	22	20	
6	36	30	25	22	33	27	23	20	23	20	18	
7	34	27	22	19	31	25	21	18	21	18	16	
8	31	24	20	17	29	22	19	16	19	16	14	
9	29	22	18	15	27	21	17	14	17	14	12	
10	27	20	16	13	25	19	15	13	16	13	11	

Based on floor reflectance of 20

LUMINANCE DATA (CD/M²)

Vertical Angle	Horizontal Angles		
	0	45	90
45	6184	2208	1694
55	5172	1519	1143
65	4258	969	672
75	3244	541	350
85	1817	133	75

i All IES files for other lamping are available for download at: www.axislighting.com

● INTEGRATED CONTROL OPTIONS

TWIN BEAM 2 luminaires allow the use of integrated controls such as daylight sensors (DS), occupancy sensors (OS) and combination daylight/occupancy sensors (DOS). These options can be seamlessly integrated into our luminaires. The control system could be used to optimize the lighting of the space by reducing energy consumption through daylight harvesting and occupancy, thereby improving the overall interior environment and allowing for LEED credits.

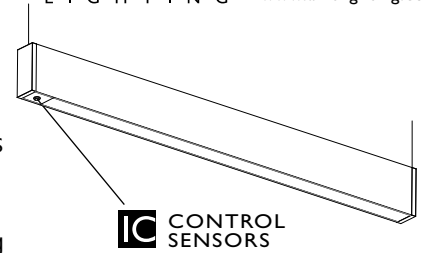

- Consult factory for other options.

SENSORS	BRAND	Model	TYPE	CODE	COMPATIBLE DIMMING BALLAST
Daylight Sensor (DS)	Lutron	EC-DIR-WH	Daylight	LD	EcoSystem
	Wattstopper	FD-301	Daylight	WD	0-10V
	Philips	Luxsense	Daylight	PL	0-10V
Occupancy Sensor (OS)	Wattstopper	FS-205	PIR Occupancy	WP1	Programmed Rapid Start
		FS-355	PIR Occupancy	WP2	Programmed Rapid Start
		FM-105	High Frequency Occupancy	WH	Programmed Rapid Start
Daylight & Occupancy Sensors (DOS)	Philips	Actilume	Daylight & PIR Occupancy	PA	DALI or 0-10V

● PHOTOMETRIC DATA

I T5



PHOTOMETRIC CURVE

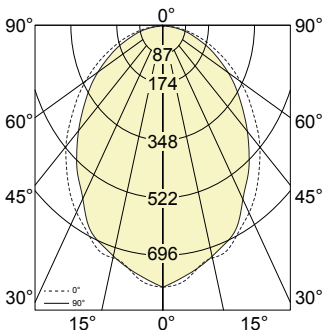

Test Lamp: **1xF28T5**
IES FILE: TB-F-4-T5-1D

Efficiency: **55.6%**

CANDELA DISTRIBUTION

Vertical Angle	Horizontal Angles					Zonal Lumens
	0	22.5	45	67.5	90	
0	783	783	783	783	783	
5	765	758	746	743	753	41
15	705	699	691	687	684	167
25	614	605	584	572	568	257
35	504	496	474	454	448	296
45	387	376	356	338	332	285
55	278	266	252	238	234	241
65	178	171	159	149	146	177
75	96	93	85	75	76	107
85	30	26	20	16	15	40
90	2	1	0	0	0	

LUMINANCE DATA (CD/M²)

Vertical Angle	Horizontal Angles		
	0	45	90
45	7049	2559	1946
55	5974	1748	1295
65	4837	1102	791
75	3707	601	414
85	2134	150	86

COEFFICIENTS OF UTILIZATION (%)

Ceiling	80			70			50				
	70	50	30	10	70	50	30	10	50	30	10
Wall	70	50	30	10	70	50	30	10	50	30	10
0	66	66	66	66	65	65	65	65	62	62	62
1	61	59	56	54	60	57	55	53	55	53	52
2	56	52	48	45	54	51	47	45	49	46	44
3	51	46	42	38	50	45	41	38	43	40	37
4	47	41	36	33	46	40	36	33	39	35	32
5	44	37	32	29	43	36	32	28	35	31	28
6	41	33	29	25	39	33	28	25	32	28	25
7	38	31	26	23	37	30	26	23	29	25	22
8	35	28	23	20	34	28	23	20	27	23	20
9	33	26	21	18	32	26	21	18	25	21	18
10	31	24	20	17	30	24	20	17	23	19	17

Based on floor reflectance of 20

i All IES files for other lamping are available for download at: www.axislighting.com