

Project _____

Type _____

Notes _____

PERFORMANCE PER LINEAR FOOT AT 3500K

NOMINAL LUMEN OUTPUT	INPUT WATTS*	EFFICACY
500 lm/ft	5.27 W/ft	102 lm/W
600 lm/ft	5.45 W/ft	111 lm/W
800 lm/ft	7.17 W/ft	111 lm/W
1000 lm/ft	8.95 W/ft	112 lm/W

Please consult factory for custom lumen output and wattage.

Round

Wedge

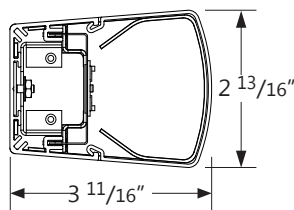
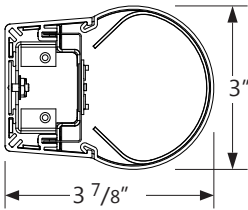

Ordering Guide

PRODUCT ID	NOM. LUMENS/FT	CRI	COLOUR TEMP.	S SHIELDING	LENGTH/FT	FINISH
PRWLED Round Wall LED	500 500 lm/ft - Minimum	80 80 CRI	27 2700 K	S satin lens	2 2'	AP aluminum paint
PWWLED Wedge Wall LED	1000 1000 lm/ft - Maximum	90 90 CRI	30 3000 K		4 4'	W white
			35 3500 K		6 6'	BLK black
			40 4000 K		8 8'	C custom
					12 12'	
					S# system run	

Outputs between listed min and max are available. Consult factory for outputs outside of the listed range.

VOLTAGE	DRIVER	CIRCUITS	BATTERY (OPTIONAL)	OTHER (OPTIONAL)
120 120 V	DP dimming (0-10V) 1% LT Lutron ⁽¹⁾ BI bi-level dimming O other ⁽²⁾	1 1 circuit	B# battery pack 4' sections ⁽⁴⁾	F fuse ⁽⁵⁾
277 277 V		2 2 circuits		
347 347 V		+E(#) emergency circuit ⁽³⁾		
UNV universal		+NL(#) night light circuit ⁽³⁾		
		+GTD(#) generator transfer device ⁽³⁾		

(1) Specify system
(2) Please consult factory; see page 2
(3) Specify quantity
(4) Specify quantity
Not available with 347V
Please consult factory
(5) Requires 120V or 277V

IC CONTROLS (OPTIONAL)	CUSTOM (OPTIONAL)
DS# daylight sensor	C custom
OS# occupancy sensor	
DOS# daylight & occupancy sensor	
EN# Enlighted integral ⁽⁶⁾	
ENR# Enlighted remote ⁽⁷⁾	
WC# wireless control dimming	
(6) For flush option only; Please consult factory (7) Please consult factory Specify quantity. Requires 8" blank See integrated controls guide for more details.	Please specify

● LIGHT DISTRIBUTION

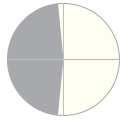

direct/indirect

● MOUNTING OPTIONS

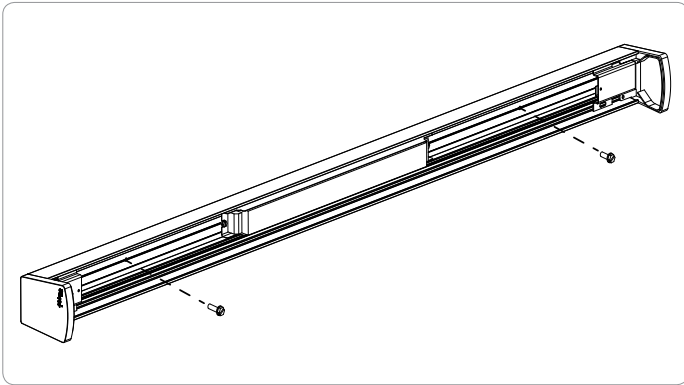

MOUNTING POINT

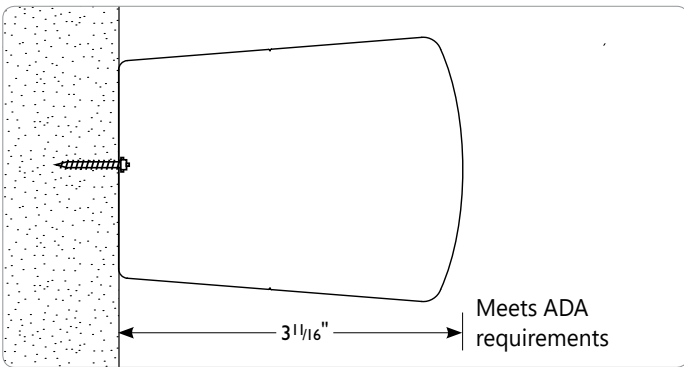

SIDE DETAIL

i Installation sheets for all mounting options are available at www.axislighting.com

● FINISH

Powder coated and custom finishes are also available.

● APPROVALS

Certified to UL and CUL standards 
 Meets ADA requirements.
 Suitable for damp locations.

● WEIGHT

Wall LED 4 ft	8 lbs / 3.9 kg
Wall LED 8 ft	16 lbs / 7.7 Kg
Wall LED 12 ft	25 lbs / 11.6 Kg

● OPTICS

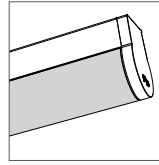

S satin lens

SATIN LENS

PMMA satin finish (0.060" nominal) 68% trans.

● SYSTEMS (S#)

Runs of PRIME LED that are greater than 12ft in length are designated as systems (S#). This means that the run is comprised of a combination of sections to be assembled on site using our joining system. For more information on systems and joining, please refer to the PRIME LED installation sheets available for download at www.axislighting.com

● OTHER MOUNTING OPTIONS

PRIME LED is also available in pendant and surface mounted options.

i Specification sheets for all mounting options are available for download at www.axislighting.com

● SPECIFICATIONS

CONSTRUCTION

Housing	Extruded aluminium (0.070" nominal) Up to 70% recycled content
End Cap	Die cast zinc (0.080" nominal)
Joiners	Die cast zinc (0.070" nominal)
Interior Brackets	Die formed sheet steel (20 gauge)
Reflectors	Die formed sheet steel (18 gauge)
Lens joiners	Die cast zinc (0.070" nominal)
Satin lens	PMMA satin finish (0.060" nominal) 68% trans.

ELECTRICAL

Input Voltage	120V, 277V, 347V, UNV.
Driver	Dimming, HiLume, EcoSystem, DALI,
CRI	Minimum 80 or 90 color rendering index
CCT	Choice of 2700K, 3000K, 3500K and 4000k color temperature with a great color consistency (within 3.5-step MacAdam ellipse).
LED life	Minimum 50,000h with 70% of lumen maintenance in 25°C ambient temperature, in compliance with IES LM-80 testing measurements.

Thermal management

Aluminium housing acting as the heat sink to maximize life.

Emergency

Emergency battery pack or emergency circuit optional.

● **INTEGRATED CONTROLS**

PRIME LED luminaires allow the use of integrated controls such as daylight sensors (DS), occupancy sensors (OS) and combination daylight/occupancy sensors (DOS). These options can be seamlessly integrated into our luminaires. The control system could be used to optimize the lighting of the space by reducing energy consumption through daylight harvesting and occupancy, thereby improving the overall interior environment and allowing for LEED credits.

- Consult factory for other options.

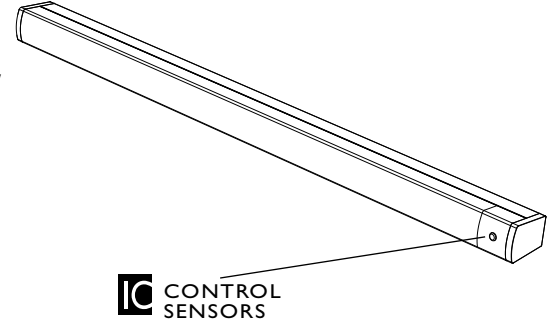

The integrated control systems offered are:

● **DAYLIGHT HARVESTING (DS):**

With Daylight sensors, maximum lamp output is reduced according to the available amount of natural light. By reducing maximum lamp output, energy consumption is reduced by up to 20 percent in a process known as "Daylight Harvesting".

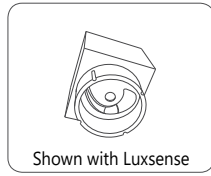

Shown with Luxsense
EC-DIR-WH, FD-301
Luxsense, Micro Luxsense

● **OCCUPANCY (OS):**

When a room is vacated, occupancy sensors ensure the light will be turned off after a programmed delay as well as ensuring that light remains on while the room is occupied.

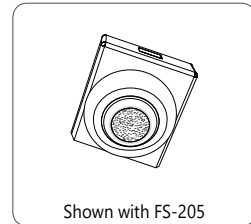

Shown with FS-205
FS-205, FS-355,
FS-155 - Line Voltage
FS-505, FS-505C

● **DAYLIGHT HARVESTING AND OCCUPANCY (DOS):**

ACTILUME, a combination of Daylight & Occupancy sensor from Philips, along with a 0-10V or DALI driver can be used in one form factor.

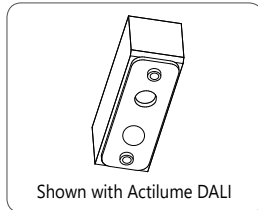

Shown with Actilume DALI
Actilume 1-10V
Actilume DALI

● **INSTALLATION EXAMPLE**

Sensor location option

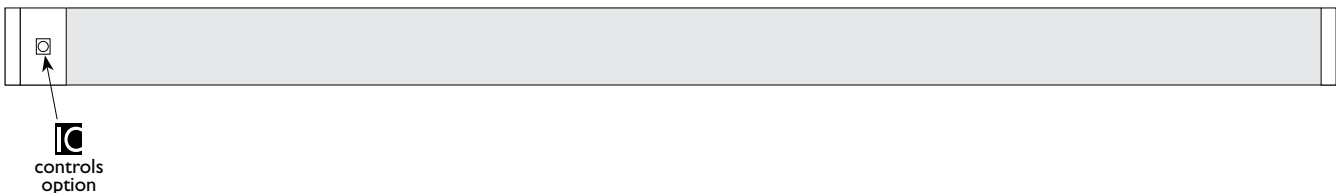

● **INTEGRATED CONTROL OPTIONS**

SENSORS	BRAND	Model	TYPE
Daylight Sensor (DS)	Lutron	EC-DIR-WH	Daylight, IR
	Wattstopper	FD-301	Daylight
	Philips	Luxsense, LR1220/00	Daylight
	Philips	Micro Luxsense	Daylight
	Wattstopper	LS-102	Light Saver (Ambient light level)
Occupancy Sensor (OS)	Wattstopper	FS-205v2	PIR Occupancy & Ambient light level
	Wattstopper	FS-355 (need lenses)	PIR Occupancy & Ambient light level
	Wattstopper	FS-155	PIR Occupancy & Ambient light level
	Wattstopper	FS-505	Ultrasonic Occupancy (Staircase)
	Wattstopper	FS-505C	Ultrasonic Occupancy (Open Area)
	Wattstopper	FM-105	High Frequency Occupancy (Wet)
	Wattstopper	FS-305 (need Lenses)	PIR Occupancy
	Wattstopper	FS-305 RC	PIR Occupancy & Ambient light level
	Lutron TriPak Wireless	LRF2-OCR2B-P-WH	PIR Occupancy
	Lutron	LOS-CDT	Ultrasonic Occupancy + PIR
	Lutron	LOS-CIR	PIR Occupancy
Daylight & Occupancy Sensors (DOS)	Philips	Actilume, LR11655	Daylight & PIR Occupancy
	Creston	GLS Series	Daylight and/or PIR Occupancy
	Echoflex	MOS Series	Daylight and/or PIR Occupancy
Enlighted sensor (EN, ENR)	Enlighted integral / remote	SU-3E-00	Daylight, Occupancy & Temperature

● **PHOTOMETRIC DATA**

600 lm/ft

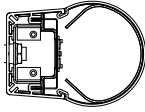

PHOTOMETRIC CURVE

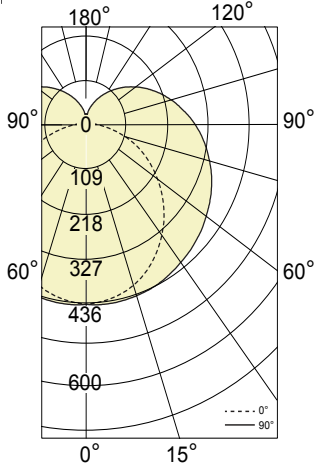

Luminaire Lumens: 600 lm/ft
Input Watts: 5.45 W/ft
Efficacy: 111 lm/W

IES FILE: PRWLED-B3-MF-600-80-35-4.IES
 TESTED ACCORDING TO IES LM-79-2008

CANDELA DISTRIBUTION

Vertical Angle	Horizontal Angles				
	0	22.5	45.0	67.5	90
0	432	432	432	432	432
5	428	431	430	432	434
15	412	418	422	428	432
25	381	390	404	419	426
35	337	351	379	403	414
45	283	304	348	385	399
55	221	253	313	362	380
65	154	200	276	336	357
75	86	149	239	305	328
85	25	107	204	272	296
90	2	90	186	254	277
95	3	77	169	236	259
105	7	59	140	200	221
115	12	49	114	166	184
125	15	42	92	133	148
135	17	34	72	103	114
145	18	27	50	76	84
155	21	23	35	49	58
165	24	22	25	28	37
175	26	26	24	20	12
180	23	23	23	23	23

ZONAL LUMENS

Zone	Lumens
0	
0-10	41
10-20	119
20-30	186
30-40	236
40-50	266
50-60	275
60-70	265
70-80	238
80-90	203
90-100	167
100-110	136
110-120	106
120-130	78
130-140	53
140-150	32
150-160	17
160-170	8
170-180	2

LUMINANCE DATA (cd/m²)

Vertical Angle	Horizontal Angles		
	0	45	90
45	4385	4303	4597
55	4182	4362	4833
65	3894	4564	5245
75	3434	5048	5916
85	2556	6224	7197

500 lm/ft

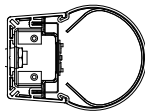

PHOTOMETRIC CURVE

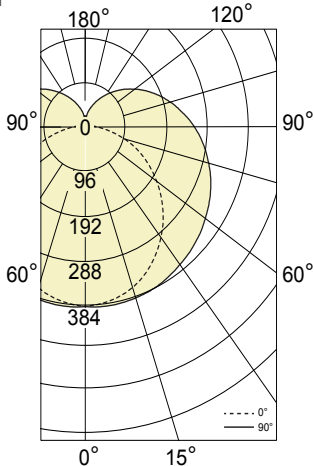

Luminaire Lumens: 500 lm/ft
Input Watts: 5.27 W/ft
Efficacy: 102 lm/W

IES FILE: PRWLED-B3-MF-500-80-30-4.IES
 TESTED ACCORDING TO IES LM-79-2008

CANDELA DISTRIBUTION

Vertical Angle	Horizontal Angles				
	0	22.5	45.0	67.5	90
0	382	382	382	382	382
5	379	381	380	382	384
15	365	370	373	379	382
25	337	345	357	371	377
35	298	311	335	357	366
45	250	269	308	341	353
55	196	224	277	320	336
65	136	177	244	297	316
75	76	132	211	270	290
85	22	95	180	241	262
90	2	80	165	225	245
95	3	68	150	209	229
105	6	52	124	177	196
115	11	43	101	147	163
125	13	37	81	118	131
135	15	30	64	91	101
145	16	24	44	67	74
155	19	20	31	43	51
165	21	19	22	25	33
175	23	23	21	18	11
180	20	20	20	20	20

ZONAL LUMENS

Zone	Lumens
0	
0-10	36
10-20	106
20-30	165
30-40	209
40-50	235
50-60	243
60-70	234
70-80	211
80-90	179
90-100	148
100-110	120
110-120	94
120-130	69
130-140	47
140-150	29
150-160	15
160-170	7
170-180	2

LUMINANCE DATA (cd/m²)

Vertical Angle	Horizontal Angles		
	0	45	90
45	3879	3807	4067
55	3700	3859	4276
65	3445	4038	4640
75	3038	4466	5234
85	2261	5506	6367

lighting facts
A Program of the U.S. DOE

Light Output (Lumens) 2151
Watts 21.08
Lumens per Watt (Efficacy) 102

Color Accuracy
 Color Rendering Index (CRI) 83

Light Color
 Correlated Color Temperature (CCT) 3007 (Bright White)

2700K 3000K 3000K 4500K 4500K 6500K

All results are according to IESNA LM-79-2005. Approved Method for the Electrical and Photometric Testing of Solid-State Lighting. The U.S. Department of Energy (DOE) verifies product test data and results.

Visit www.lightingfacts.com for the Label Reference Guide.

Registration Number: AEYL-XVWV46 (10/20/2015)
 Model Number: PRLED-B3-500-30-ST-4-W-120-D-1-(NA)-(NONE)-(NONE)-(NONE)-(NONE)
 Type: Luminaire - Linear

i All IES files are available for download at: www.axislighting.com

● **PHOTOMETRIC DATA**

800 lm/ft

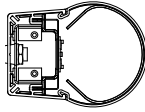

PHOTOMETRIC CURVE

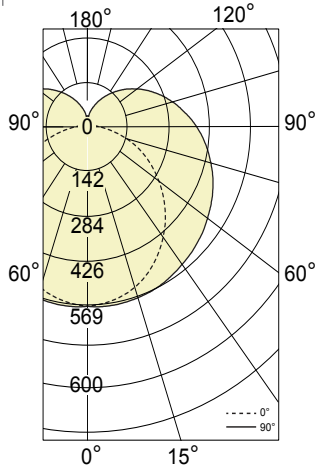

Luminaire Lumens: 800 lm/ft
Input Watts: 7.17 W/ft
Efficacy: 111 lm/W

IES FILE: PRWLED-B3-MF-800-80-35-4.IES
 TESTED ACCORDING TO IES LM-79-2008

CANDELA DISTRIBUTION

Vertical Angle	Horizontal Angles				
	0	22.5	45.0	67.5	90
0	432	432	432	432	432
5	428	431	430	432	434
15	412	418	422	428	432
25	381	390	404	419	426
35	337	351	379	403	414
45	283	304	348	385	399
55	221	253	313	362	380
65	154	200	276	336	357
75	86	149	239	305	328
85	25	107	204	272	296
90	2	90	186	254	277
95	3	77	169	236	259
105	7	59	140	200	221
115	12	49	114	166	184
125	15	42	92	133	148
135	17	34	72	103	114
145	18	27	50	76	84
155	21	23	35	49	58
165	24	22	25	28	37
175	26	26	24	20	12
180	23	23	23	23	23

ZONAL LUMENS

Zone	Lumens
0	
0-10	54
10-20	157
20-30	244
30-40	310
40-50	349
50-60	360
60-70	347
70-80	312
80-90	265
90-100	219
100-110	178
110-120	139
120-130	103
130-140	70
140-150	42
150-160	23
160-170	10
170-180	3

LUMINANCE DATA (cd/m²)

Vertical Angle	Horizontal Angles		
	0	45	90
45	4385	4303	4597
55	4182	4362	4833
65	3894	4564	5245
75	3434	5048	5916
85	2556	6224	7197

1000 lm/ft

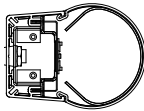

PHOTOMETRIC CURVE

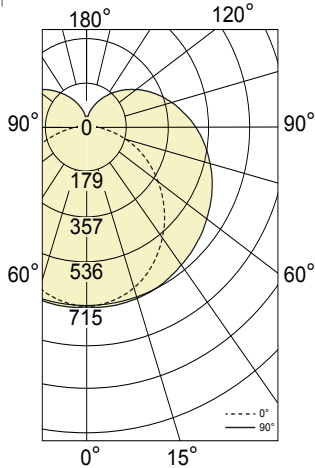

Luminaire Lumens: 1000 lm/ft
Input Watts: 8.95 W/ft
Efficacy: 112 lm/W

IES FILE: PRWLED-B3-MF-1000-80-30-4.IES
 TESTED ACCORDING TO IES LM-79-2008

CANDELA DISTRIBUTION

Vertical Angle	Horizontal Angles				
	0	22.5	45.0	67.5	90
0	382	382	382	382	382
5	379	381	380	382	384
15	365	370	373	379	382
25	337	345	357	371	377
35	298	311	335	357	366
45	250	269	308	341	353
55	196	224	277	320	336
65	136	177	244	297	316
75	76	132	211	270	290
85	22	95	180	241	262
90	2	80	165	225	245
95	3	68	150	209	229
105	6	52	124	177	196
115	11	43	101	147	163
125	13	37	81	118	131
135	15	30	64	91	101
145	16	24	44	67	74
155	19	20	31	43	51
165	21	19	22	25	33
175	23	23	21	18	11
180	20	20	20	20	20

ZONAL LUMENS

Zone	Lumens
0	
0-10	68
10-20	197
20-30	307
30-40	389
40-50	439
50-60	453
60-70	436
70-80	392
80-90	334
90-100	276
100-110	224
110-120	175
120-130	129
130-140	88
140-150	53
150-160	28
160-170	13
170-180	4

LUMINANCE DATA (cd/m²)

Vertical Angle	Horizontal Angles		
	0	45	90
45	3879	3807	4067
55	3700	3859	4276
65	3445	4038	4640
75	3038	4466	5234
85	2261	5506	6367

LED lighting facts
A Program of the U.S. DOE

Light Output (Lumens) 2151
Watts 21.08
Lumens per Watt (Efficacy) 102

Color Accuracy
Color Rendering Index (CRI) 83

Light Color
Correlated Color Temperature (CCT) 3007 (Bright White)

2700K 3000K 4500K 6500K

All results are according to IESNA LM-79-2008: Approved Method for the Electrical and Photometric Testing of Solid-State Lighting. The U.S. Department of Energy (DOE) verifies product test data and results.

Visit www.lightingfacts.com for the Label Reference Guide.

Registration Number: AEYL-XVWW46 (10/20/2015)
 Model Number: PRLED-B3-500-30-ST-4-W-120-D-1-(NA)-(NONE)-(NONE)-(NONE)-(NONE)
 Type: Luminaire - Linear

i All IES files are available for download at: www.axislighting.com