



SURFACE MOUNT

PROJECT INFORMATION

Project:

Type:

Notes:

DIMENSIONS

END VIEW

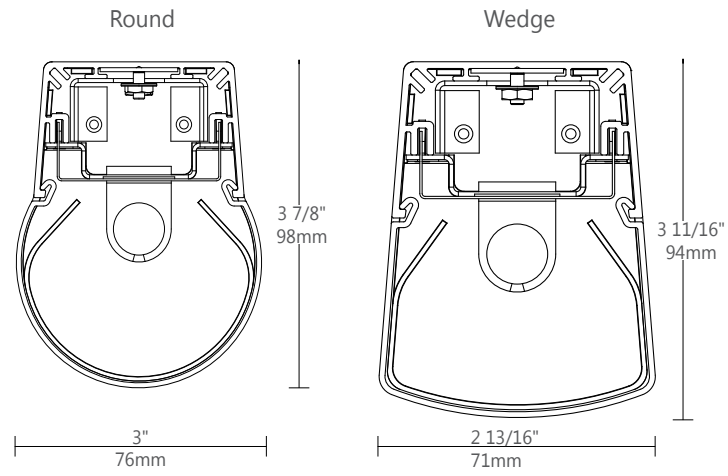

ORDERING CODE

1	2	3	4	5	6	7	8	9	10	11	12	13	14
---	---	---	---	---	---	---	---	---	----	----	----	----	----

PRODUCT SPECIFICATIONS

1 PRODUCT ID	2 OPTICS	3 LENGTH/FT	4 LAMP	5 LAMP CONFIGURATION	6 FINISH
PRS round surface	S satin lens	2 2'	T5 T5	1 1 lamp	AP aluminum paint
PWS wedge surface		4 4'	T5HO T5HO		W white
		6 6'	T8 T8		BLK black
		8 8'			C custom
		12 12'			
		S# System Run			

7 VOLTAGE	8 BALLAST	9 CIRCUITS	10 MOUNTING/SUSPENSION	11 BATTERY (OPTIONAL)
120 120V	D dimming	1 1 regular	S surface drywall ceiling	B# battery pack 4' sections
277 277V	E instant start ⁽²⁾	2A/B 2 alternating	SB surface t-bar ceiling	
347 347V ⁽¹⁾	ERS program start	+E(#) emergency section ⁽³⁾	SC surface solid ceiling	
UNV universal	BI bi-level dimming	+NL(#) night light section ⁽³⁾		
		+GTD(#) generator transfer device ⁽³⁾		

(1) Consult factory

(2) Available with T8 lamp only

(3)Specify quantity

12 OTHER (OPTIONAL)	13 IC CONTROLS (OPTIONAL)	14 CUSTOM (OPTIONAL)
F fuse	DS# daylight sensor	C custom
	OS# occupancy sensor	
	DS+OS# daylight+occupancy sensor	
	DOS# daylight&occupancy sensor	
	See integrated controls guide for further details	Please specify



● LIGHT DISTRIBUTION

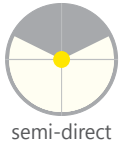

semi-direct

● MOUNTING SPACING

Between Mounting Points:

PRIME 4' (24" C.C.)

PRIME 8' (72" C.C.)

PRIME 12' (120" C.C.)

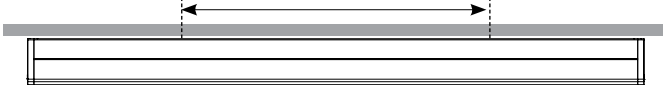

● MOUNTING DETAILS

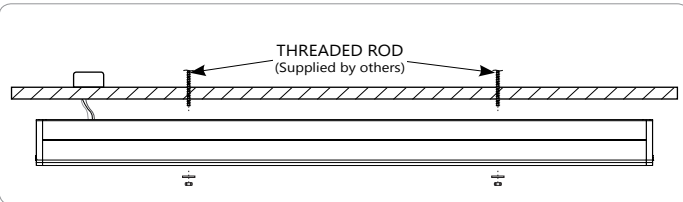

THREADED ROD
(Supplied by others)

S SURFACE MOUNT DRYWALL CEILING

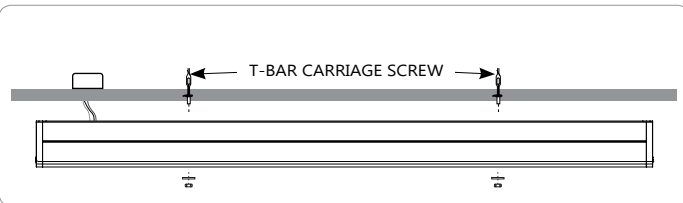

T-BAR CARRIAGE SCREW

SB SURFACE MOUNT T-BAR CEILING

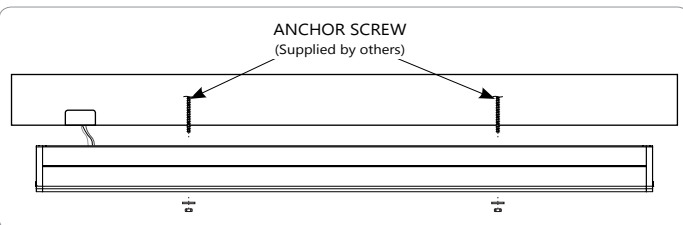

ANCHOR SCREW
(Supplied by others)

SC SURFACE MOUNT SOLID CEILING

i Installation sheets for all mounting options are available at: www.axislighting.com

● SYSTEMS (S#)

Runs of PRIME that are greater than 12ft in length are designated as systems (S#). This means that the run is comprised of a combination of sections to be assembled on site using our joining system. For more information on systems and joining, please refer to the PRIME installation sheets available for download at www.axislighting.com

● OTHER MOUNTING OPTIONS

PRIME is also available in pendant and wall mounted options.

i Specification sheets for all mounting options are available for download at www.axislighting.com

● CONSTRUCTION

Housing	Extruded aluminium (0.070" nominal) up to 70% recycled content
End Cap	Die cast zinc (0.080" nominal)
Joiners	Die cast zinc (0.070" nominal)
Interior Brackets	Die formed Sheet Steel (20 gauge)
Reflectors	Die formed Sheet Steel (18 gauge)
Lens joiners	Die cast zinc (0.070" nominal)
Satin lens	PMMA satin finish (0.060" nominal) 68% trans.

● WEIGHT

4 ft	8 lbs / 3.9 kg
8 ft	16 lbs / 7.7 Kg
12 ft	25 lbs / 11.6 Kg

● OPTICS

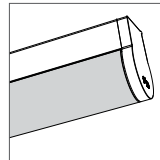

S satin lens

● FINISH

Aluminium paint, Powder Coated and custom finishes are also available.

● ELECTRICAL

Ballast	Electronic IS, Electronic Rapid Start, Dimming (0-10V, Line, EcoSystem, DALI), BI-level dimming With preinstalled ballast disconnect as per NEC & CEC
Emergency	Emergency battery pack or emergency circuit
Voltage	120V, 277V, 347V, UNV

● APPROVALS

Certified to UL and CUL standards Suitable for damp locations.

● INTEGRATED CONTROL OPTIONS

PRIME luminaires allow the use of integrated controls such as daylight sensors (DS), occupancy sensors (OS), individual daylight sensors and occupancy sensors (DS+OS), and combination daylight/occupancy sensors (DOS). These options can be seamlessly integrated into our luminaires. The control system could be used to optimize the lighting of the space by reducing energy consumption through daylight harvesting and occupancy, thereby improving the overall interior environment and allowing for LEED credits.

- Consult factory for other options.
- Refer to IC brochure for more information.

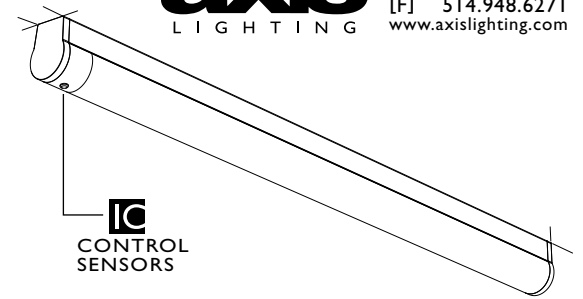

SENSORS	BRAND	Model	TYPE	CODE	COMPATIBLE DIMMING BALLAST
Daylight Sensor (DS)	Lutron	EC-DIR-WH	Daylight	LD	EcoSystem
	Wattstopper	FD-301	Daylight	WD	0-10V
	Philips	Luxsense	Daylight	PL	0-10V
Occupancy Sensor (OS)	Wattstopper	FS-205	PIR Occupancy	WP1	Programmed Rapid Start
		FS-355	PIR Occupancy	WP2	Programmed Rapid Start
		FM-105	High Frequency Occupancy	WH	Programmed Rapid Start
Daylight & Occupancy Sensors (DOS)	Philips	Actilume	Daylight & PIR Occupancy	PA	DALI or 0-10V

● PHOTOMETRIC DATA

PRS | T5

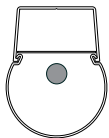

CANDELA DISTRIBUTION

Vertical Angle	Horizontal Angles				Zonal Lumens
	0	30	60	90	
0	363	363	363	363	
10	342	358	357	358	67
20	335	339	353	363	130
30	302	320	346	366	182
40	264	290	342	364	222
50	219	259	330	355	245
60	163	226	309	346	251
70	109	195	292	329	242
80	54	161	269	310	222
90	14	136	246	287	196
100	8	111	218	258	167
110	11	90	185	223	135
120	15	78	152	185	105
130	21	66	123	148	76
140	26	56	101	118	53
150	30	44	74	87	32
160	33	36	55	59	17
170	34	32	32	42	7
180	33	33	33	33	

COEFFICIENTS OF UTILIZATION (%)

Ceiling	80				70				50			
	70	50	30	10	70	50	30	10	50	30	10	10
Wall	70	50	30	10	70	50	30	10	50	30	10	10
0	91	91	91	91	86	86	86	86	77	77	77	77
1	80	75	70	66	75	71	66	63	63	59	56	56
2	71	63	57	51	67	60	54	49	53	48	44	44
3	64	55	47	41	60	52	45	39	46	40	36	36
4	59	48	40	34	55	45	38	33	40	34	30	30
5	53	42	35	29	50	40	33	28	36	30	25	25
6	49	38	30	25	46	36	29	24	32	26	22	22
7	45	34	27	21	42	32	25	21	29	23	19	19
8	42	31	24	19	39	29	23	18	26	21	17	17
9	39	28	21	17	37	27	20	16	24	18	15	15
10	37	26	19	15	34	24	18	14	22	17	13	13

Based on floor reflectance of 20

LUMINANCE DATA (CD/M²)

Vertical Angle	Horizontal Angles			
	0	30	60	90
45	3432	2402	2317	2332
55	3236	2207	2197	2243
65	2960	2058	2123	2200
75	2589	1942	2104	2190
85	2127	1904	2129	2230

PHOTOMETRIC CURVE

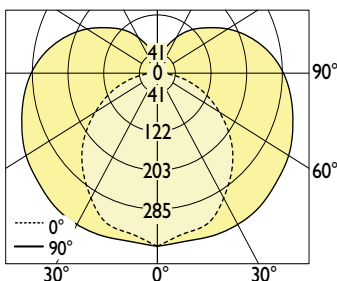

Test Lamp: 1xF28T5

IES FILE: PR-S-4-T5-1.ies

Efficiency: 81.3%

i All IES files are available for download at: www.axislighting.com



PHOTOMETRIC DATA

PWS I T5

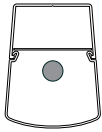

PHOTOMETRIC CURVE

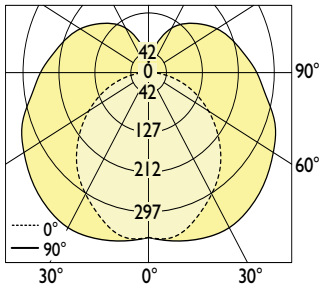

Test Lamp: 1xF28T5
IES FILE: PW-S-4-T5-1.ies

Efficiency: 81.2%

CANDELA DISTRIBUTION

Vertical Angle	Horizontal Angles				Zonal Lumens
	0	30	60	90	
0	352	352	352	352	
10	356	356	373	365	68
20	330	343	365	376	132
30	299	330	365	382	189
40	264	309	356	375	230
50	216	278	342	360	255
60	164	240	312	341	255
70	109	195	282	318	237
80	55	152	247	282	205
90	13	120	219	256	174
100	8	105	197	230	152
110	9	98	175	209	133
120	9	89	161	187	110
130	10	78	139	161	85
140	10	64	118	137	61
150	10	52	92	110	37
160	10	36	62	74	18
170	11	20	32	39	5
180	14	14	14	14	

COEFFICIENTS OF UTILIZATION (%)

Ceiling	80				70				50			
	70	50	30	10	70	50	30	10	50	30	10	
Wall	70	50	30	10	70	50	30	10	50	30	10	
0	91	91	91	91	86	86	86	86	77	77	77	
1	80	75	71	67	75	71	67	63	63	60	57	
2	72	64	57	52	67	60	54	50	53	49	45	
3	65	55	48	42	61	52	45	40	46	41	36	
4	59	48	41	35	55	46	39	33	40	35	30	
5	54	43	35	29	50	40	33	28	36	30	26	
6	49	38	30	25	46	36	29	24	32	26	22	
7	46	34	27	22	43	32	26	21	29	23	19	
8	42	31	24	19	40	29	23	18	26	21	17	
9	39	28	21	17	37	27	21	16	24	19	15	
10	37	26	19	15	35	25	19	14	22	17	13	

Based on floor reflectance of 20

LUMINANCE DATA (CD/M²)

Vertical Angle	Horizontal Angles			
	0	30	60	90
45	3617	2682	2499	2471
55	3418	2452	2326	2320
65	3160	2205	2166	2214
75	2775	1959	2041	2113
85	2262	1797	1972	2055

PRS I T5HO

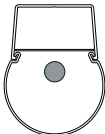

PHOTOMETRIC CURVE

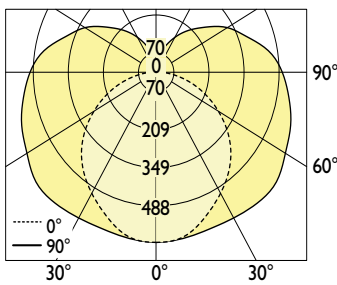

Test Lamp: 1xF54T5HO
IES FILE: PR-S-4-T5HO-1.ies

Efficiency: 81.3%

CANDELA DISTRIBUTION

Vertical Angle	Horizontal Angles				Zonal Lumens
	0	30	60	90	
0	622	622	622	622	
10	612	610	596	617	116
20	565	588	601	611	223
30	511	551	598	615	314
40	453	510	581	625	383
50	379	448	568	623	423
60	285	393	540	593	434
70	186	336	505	568	418
80	90	281	470	535	381
90	22	235	424	501	338
100	14	188	373	452	288
110	20	156	323	382	233
120	26	137	258	326	181
130	36	114	219	256	133
140	46	94	172	200	91
150	52	77	129	147	55
160	53	61	92	99	29
170	62	56	64	68	12
180	62	62	62	62	

COEFFICIENTS OF UTILIZATION (%)

Ceiling	80				70				50			
	70	50	30	10	70	50	30	10	50	30	10	
Wall	70	50	30	10	70	50	30	10	50	30	10	
0	91	91	91	91	86	86	86	86	77	77	77	
1	80	75	70	66	75	71	66	63	63	59	56	
2	71	63	57	51	67	60	54	49	53	48	44	
3	64	55	47	41	60	52	45	39	46	40	36	
4	59	48	40	34	55	45	38	33	40	34	30	
5	54	42	35	29	50	40	33	28	36	30	25	
6	49	38	30	25	46	36	29	24	32	26	22	
7	45	34	27	21	43	32	25	21	29	23	19	
8	42	31	24	19	39	29	23	18	26	21	16	
9	39	28	21	17	37	27	20	16	24	18	15	
10	37	26	19	15	34	24	18	14	22	17	13	

Based on floor reflectance of 20

LUMINANCE DATA (CD/M²)

Vertical Angle	Horizontal Angles			
	0	30	60	90
45	5914	4187	3965	4049
55	5624	3823	3811	3897
65	5126	3563	3692	3788
75	4387	3373	3657	3786
85	3503	3313	3693	3870

All IES files are available for download at: www.axislighting.com





PHOTOMETRIC DATA

PWS | T5HO

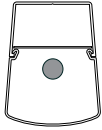

PHOTOMETRIC CURVE

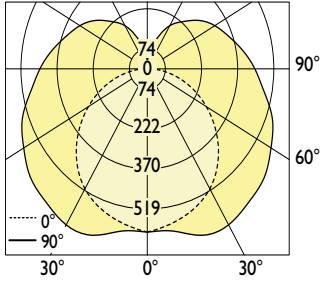

Test Lamp: 1xF54T5HO

IES FILE: PW-S-4-T5HO-1.ies

Efficiency: 81.3%

CANDELA DISTRIBUTION

Vertical Angle	Horizontal Angles				Zonal Lumens
	0	30	60	90	
0	604	604	604	604	
10	581	601	628	610	115
20	553	586	620	656	227
30	513	565	628	667	327
40	451	535	625	646	400
50	370	481	590	626	439
60	280	414	543	586	441
70	185	338	482	546	409
80	91	263	427	486	354
90	23	208	375	441	301
100	14	179	337	397	262
110	15	164	307	354	227
120	16	155	273	320	189
130	17	136	242	278	148
140	19	113	204	228	104
150	17	91	158	185	64
160	16	63	106	122	30
170	19	38	58	67	9
180	23	23	23	23	

COEFFICIENTS OF UTILIZATION (%)

Ceiling	80				70				50			
	70	50	30	10	70	50	30	10	50	30	10	
Wall	70	50	30	10	70	50	30	10	50	30	10	
0	91	91	91	91	86	86	86	86	77	77	77	
1	80	75	71	67	75	71	67	63	63	60	57	
2	72	64	57	52	67	60	54	50	54	49	45	
3	65	55	48	42	61	52	45	40	46	41	36	
4	59	48	41	35	55	46	39	33	41	35	30	
5	54	43	35	29	50	40	33	28	36	30	26	
6	49	38	30	25	46	36	29	24	32	26	22	
7	46	34	27	22	43	32	26	21	29	23	19	
8	42	31	24	19	40	29	23	18	26	21	17	
9	39	28	21	17	37	27	20	16	24	19	15	
10	37	26	19	15	35	25	19	14	22	17	13	

Based on floor reflectance of 20

LUMINANCE DATA (CD/M²)

Vertical Angle	Horizontal Angles			
	0	30	60	90
45	6180	4637	4353	4274
55	5834	4234	4032	4010
65	5363	3814	3739	3803
75	4664	3400	3510	3635
85	3809	3115	3398	3541

PRS | T8



PHOTOMETRIC CURVE

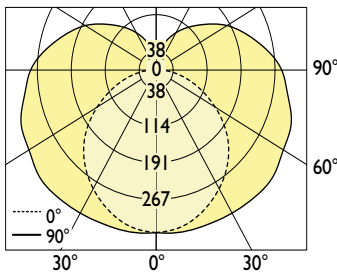

Test Lamp: 1xF03231

IES FILE: PR-S-4-T8-1.ies

Efficiency: 78.1%

CANDELA DISTRIBUTION

Vertical Angle	Horizontal Angles				Zonal Lumens
	0	30	60	90	
0	335	335	335	335	
10	328	336	334	339	63
20	309	314	332	339	121
30	283	302	325	341	171
40	250	273	320	343	209
50	207	249	314	342	232
60	153	217	300	330	240
70	98	184	278	323	232
80	50	157	263	300	215
90	13	133	241	282	191
100	8	109	212	250	163
110	10	89	183	216	133
120	16	77	151	184	104
130	21	66	124	147	76
140	25	55	98	116	52
150	30	46	74	89	32
160	33	36	55	63	17
170	36	33	35	43	7
180	35	35	35	35	

COEFFICIENTS OF UTILIZATION (%)

Ceiling	80				70				50			
	70	50	30	10	70	50	30	10	50	30	10	
Wall	70	50	30	10	70	50	30	10	50	30	10	
0	87	87	87	87	83	83	83	83	74	74	74	
1	77	72	67	63	72	68	64	60	60	57	54	
2	68	61	54	49	64	57	52	47	51	46	42	
3	62	52	45	40	58	49	43	38	44	38	34	
4	56	46	38	33	52	43	36	31	38	33	28	
5	51	41	33	28	48	38	31	26	34	28	24	
6	47	36	29	24	44	34	27	23	30	25	20	
7	43	33	25	20	41	31	24	20	27	22	18	
8	40	29	23	18	38	28	22	17	25	20	16	
9	38	27	20	16	35	25	19	15	23	18	14	
10	35	25	18	14	33	23	18	14	21	16	12	

Based on floor reflectance of 20

LUMINANCE DATA (CD/M²)

Vertical Angle	Horizontal Angles			
	0	30	60	90
45	3145	2206	2113	2147
55	2958	2047	2038	2079
65	2652	1896	1973	2056
75	2295	1805	1963	2063
85	1962	1802	2017	2099

All IES files are available for download at: www.axislighting.com

● PHOTOMETRIC DATA

PWS I T8

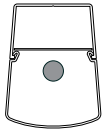

PHOTOMETRIC CURVE

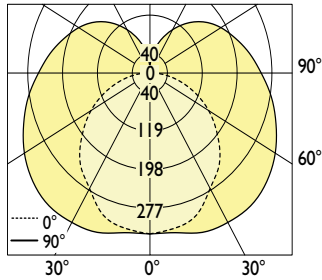

Test Lamp: 1xF03231
 IES FILE: PW-S-4-T8-1.ies
Efficiency: 78.0%

CANDELA DISTRIBUTION

Vertical Angle	Horizontal Angles				Zonal Lumens
	0	30	60	90	
0	329	329	329	329	
10	323	322	332	332	62
20	309	322	344	347	124
30	273	310	345	353	177
40	245	289	336	355	217
50	201	260	321	346	240
60	154	227	298	328	243
70	101	185	271	304	227
80	51	147	241	279	200
90	12	118	215	252	172
100	7	104	194	230	150
110	8	96	174	207	131
120	10	90	156	186	109
130	10	78	136	162	85
140	10	65	117	134	60
150	10	51	90	102	36
160	9	37	62	72	18
170	11	21	33	42	5
180	12	12	12	12	

COEFFICIENTS OF UTILIZATION (%)

Ceiling	80				70				50			
	70	50	30	10	70	50	30	10	50	30	10	
Wall	70	50	30	10	70	50	30	10	50	30	10	
0	87	87	87	87	83	83	83	83	74	74	74	
1	77	72	68	64	72	68	64	61	60	57	54	
2	69	61	55	50	64	58	52	47	51	47	43	
3	62	53	46	40	58	50	43	38	44	39	35	
4	56	46	39	33	53	44	37	32	39	33	29	
5	51	41	33	28	48	39	32	27	34	29	24	
6	47	36	29	24	44	34	28	23	31	25	21	
7	44	33	26	21	41	31	24	20	28	22	18	
8	40	30	23	18	38	28	22	17	25	20	16	
9	38	27	20	16	35	26	20	15	23	18	14	
10	35	25	18	14	33	23	18	14	21	16	13	

Based on floor reflectance of 20

LUMINANCE DATA (CD/M²)

Vertical Angle	Horizontal Angles			
	0	30	60	90
45	3244	2425	2275	2275
55	3084	2233	2129	2154
65	2863	2026	2007	2052
75	2503	1816	1913	1984
85	2060	1692	1870	1961

i All IES files are available for download at: www.axislighting.com