

● **PROJECT INFORMATION**

Project:

Type:

Notes:

● **DIMENSIONS**

SECTION VIEW

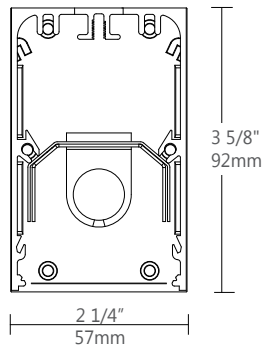

● **ORDERING CODE**

1	2	3	4	5	6	7	8	9	10	11	12	13	14	15	16
---	---	---	---	---	---	---	---	---	----	----	----	----	----	----	----

● **PRODUCT SPECIFICATIONS**

1 PRODUCT ID	2 OPTICS	3 LENGTH (FT)	4 SPECIFY LENGTH	5 LAMP	6 LAMP CONFIGURATION
BS surface	S satin lens F frosted lens ⁽¹⁾ PL semi spec. para. louvers B blank	2 2' 3 3' 4 4' 5 5' 6 6' 8 8' 12 12' S# System Run	NL nominal (3' & 4' lamps) NL4 nominal (4' lamps only) EX exact (3' & 4' lamps) EX4 exact (4' lamps only)	T5 T5 T5HO T5HO T8 T8	0 0 lamp 1 1 lamp +S staggered ⁽²⁾
(1) not recommended with staggered lamping				(2) Not available with T8 lamping.	

7 MR	8 FINISH	9 VOLTAGE	10 BALLAST	11 CIRCUITS	12 MOUNTING/SUSPENSION
M11# MR 11 halogen M11LED# MR 11 LED	AP aluminum paint W white BLK black C custom	120 120 V 277 277 V 347 347 V ⁽³⁾ UNV universal	D dimming E instant start ⁽⁴⁾ ERS program start BI bi-level dimming	1 1 regular 2A/B 2 alternating +E(#) emergency section +NL(#) night light section +GTD(#) generator transfer device +M MR	S surface drywall ceiling SB surface t-bar ceiling SC surface solid ceiling
Add 6" per lamp Requires 120V or 277V		(3) Please consult factory	(4) Available with T8 lamp only		

13 BATTERY (OPTIONAL)	14 OTHER (OPTIONAL)	15 IC CONTROLS (OPTIONAL)	16 CUSTOM (OPTIONAL)
B# battery pack 4' sections Requires 120V or 277V	F fuse EF end feed FW(#) flex whip (6' std)	DS# daylight sensor OS# occupancy sensor DOS# daylight&occupancy sensor See integrated controls guide for further details	C custom Please specify

● CONSTRUCTION

Housing	Extruded Aluminum (0.075" nominal) 70% Recycled Content
End Cap	Sheet Steel (18 ga)
Interior Brackets	Die Formed Sheet Steel (18 ga)
Reflectors	White Powder Coated Sheet Steel (22 ga)
Louvers	Die Formed Semi-Specular Aluminum (22 ga)
Blank	Extruded Aluminum (0.075" nominal)
Lenses	Extruded Acrylic (0.070" nominal) Satin: 68% trans. Frosted: 85% trans.

● JOINERS

In order to allow very long runs of BEAM 2 luminaires, Axis has developed a number of different joining systems. Special care has been taken to maximize the performance of the joiner for each BEAM option.

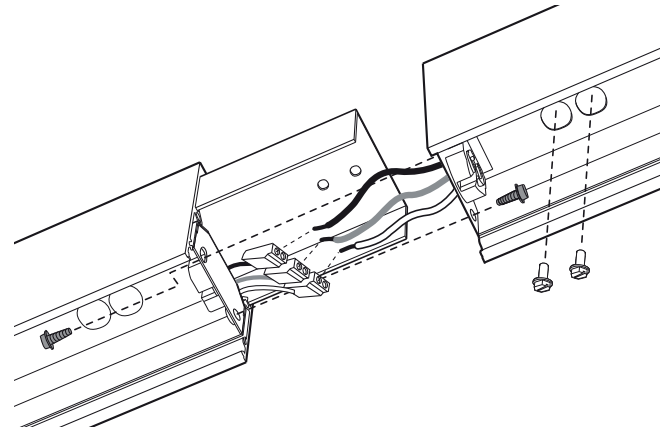

NOTE: Mount each system segment individually. Do not assemble system prior to mounting.

i Allow a minimum of 6" between end of long runs and vertical wall

● STAGGERED LAMPING

When BEAM 2 is used in continuous runs longer than 4', staggered lamping can be used to eliminate the appearance of socket shadows at the ends of the lamps. BEAM 2 uses a staggered overlap of bracket lengths (4"), along with 3' and 4' lamps, allowing us to match almost any row length requirements with optimal results. For example 3 x 3' staggered T5 lamps can be used to completely illuminate the lens of an 8' nominal luminaire.

LAMP TYPE	T5	T5HO
1 lamp	●	●

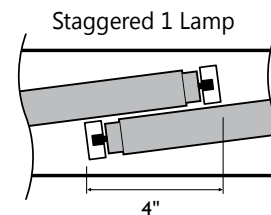

● WEIGHT

4 ft	10.5 lbs / 4.8 kg
8 ft	21.0 lbs / 9.6 kg
12 ft	31.5 lbs / 14.4 kg

● SYSTEM (S#)

BEAM 2 linear systems, with the use of a strong profile, allow for a nearly hair thin connection system of continuous runs. Lengths of 4', 8', 12' as well as custom lengths are available. Runs of BEAM 2 that are greater than 12ft in length are designated as systems (S#). This means that the run is comprised of a combination 4ft, 8ft and/or 12ft sections to be assembled on site using our joining system. For more information on systems and joining, please refer to the BEAM installation sheets available for download at www.axislighting.com.

● ELECTRICAL

Ballast Electronic IS, Electronic Rapid Start, Dimming (0-10V, Line, EcoSystem, DALI), BI-level dimming
With preinstalled ballast disconnect as per NEC & CEC

Emergency Emergency battery pack or emergency circuit

Voltage 120V, 277V, 347V, UNV

i Incorporating these components may have limitations or effect the length of the luminaire, please contact factory for more details.

● FINISH

Aluminium paint, Powder Coated and custom finishes are also available.

● APPROVALS

Certified to UL and CUL standards
 Meets NYC requirements
 Suitable for damp locations.

OPTICS

Satin & Frosted Lens - (acrylic snap-in lens)

satin: 68% trans.
 frosted: 85% trans.

Semi-spec. parabolic louver

9/16" deep blades – 5/8" spacing
 72 blades per 4'

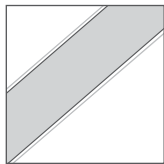

S satin lens

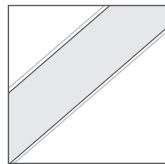

F frosted lens

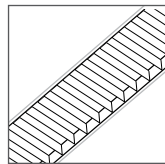

PL semi-specular parabolic louvers

CORNERS

Unlit Corners - BEAM2

features a multitude of layout patterns with the use of a number of corners, 90° corner, T or X junctions.

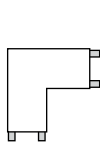
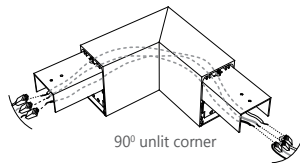

90° corner

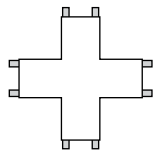

X junction

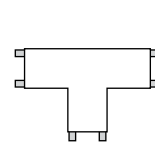

T junction

Lit Corners - In addition Axis offers 90° Wall to Ceiling lit corners.

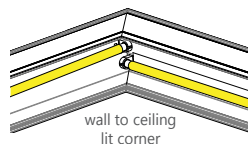

i For custom corner angles, please consult factory. Specifications sheets for all corners are available at: www.axislighting.com

MR11

Blank MR11 Halogens MR11 LED Quantity

Extruded Aluminum (0.075" nominal)
 1.4" diameter (20W / 35W)
 1.4" diameter

For every 4' fluorescent lamp section, there may be up to a maximum of 4 x MR11 lamps.

Each MR11 is placed centered on a blank section 6" in length.

Spacing

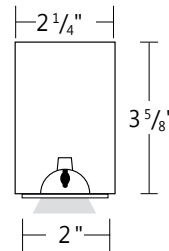

For a series of MR11's within a given section length, they will be spaced evenly on a longer blank section.

The directed light of MR11 Halogen lamps are fixed downward.

Custom spacing may be available on special request.

Between fluorescent lamps sections

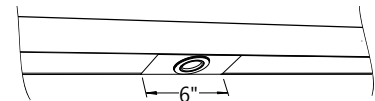

At luminaire ends

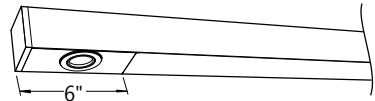

Several in a long blank section

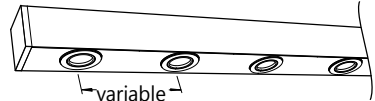

● **MOUNTING OPTIONS**

End to End Lamping:

T5/T5HO LAMP

BEAM2 4' (42⁹/₁₆" C.C.)
BEAM2 8' (88⁷/₈" C.C.)
BEAM2 12' (135³/₁₆" C.C.)

T8 LAMP

BEAM2 4' (44¹/₄" C.C.)
BEAM2 8' (92¹/₄" C.C.)
BEAM2 12' (138¹/₄" C.C.)

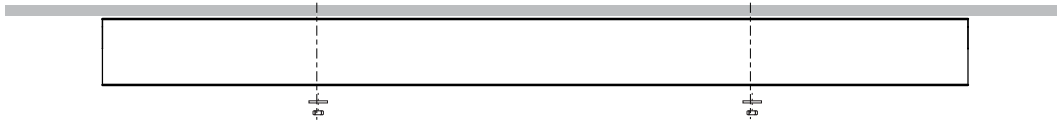

● **MOUNTING DETAILS**

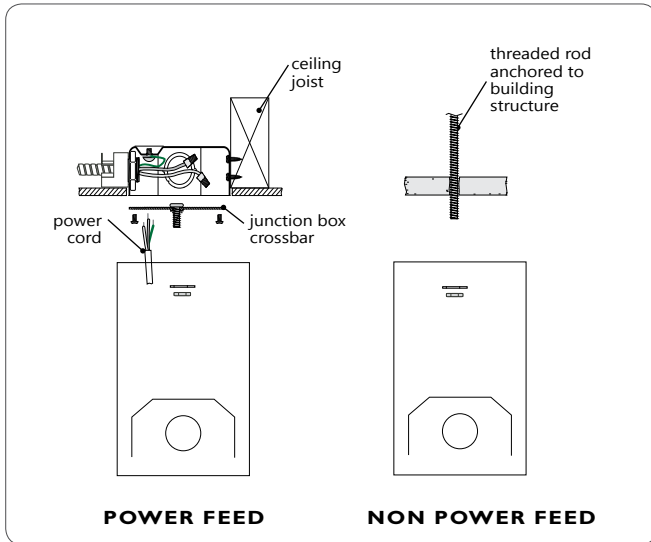

S SURFACE MOUNT DRYWALL CEILING

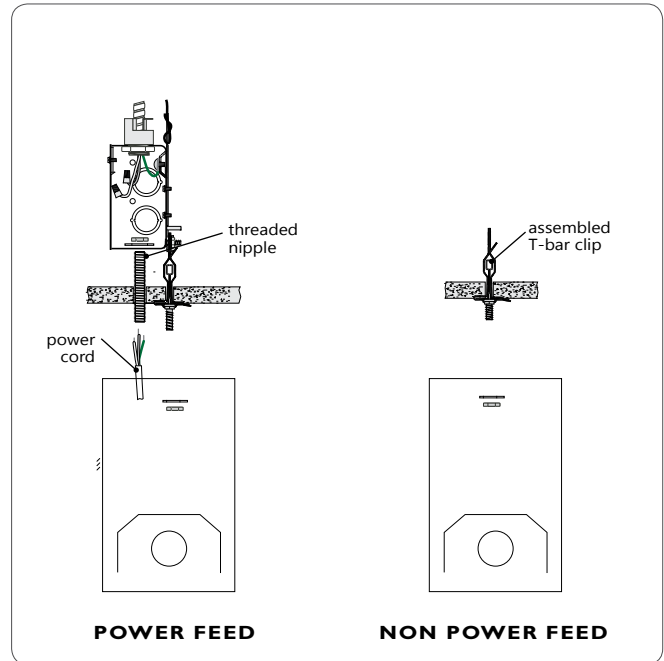

SB SURFACE MOUNT T-BAR CEILING

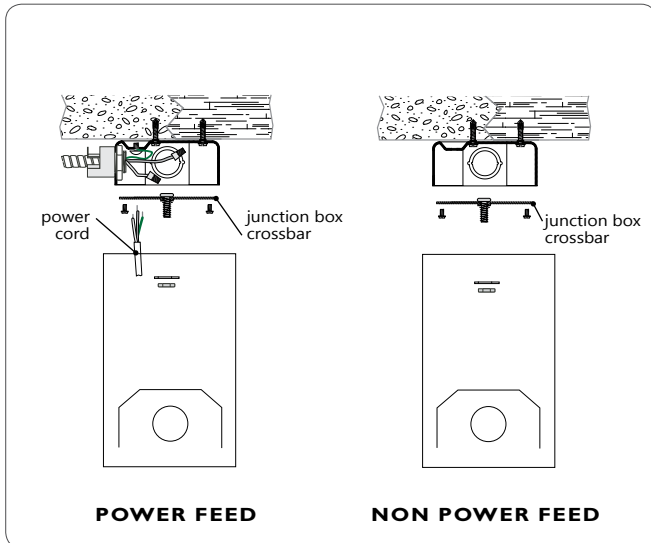

SC SURFACE MOUNT SOLID CEILING

● **OTHER MOUNTING OPTIONS**

BEAM 2 is also available with recessed, pendant, wall, asymmetric and recessed wall mounted options.

i Specification sheets and Installation sheets for all mounting for BEAM luminaires are available for download at www.axislighting.com

● **INTEGRATED CONTROL OPTIONS**

BEAM 2 luminaires allow the use of integrated controls such as daylight sensors (DS), occupancy sensors (OS), individual daylight sensors and occupancy sensors (DS+OS), and combination daylight/occupancy sensors (DOS). These options can be seamlessly integrated into our luminaires. The control system could be used to optimize the lighting of the space by reducing energy consumption through daylight harvesting and occupancy, thereby improving the overall interior environment and allowing for LEED credits.

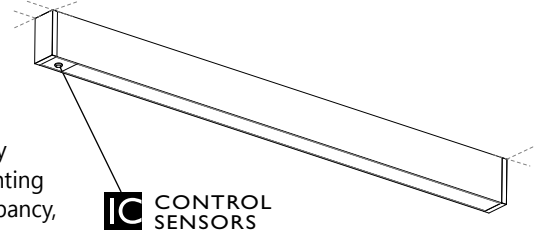

- Consult factory for other options.
- Refer to IC guide for more information.

SENSORS	BRAND	Model	TYPE	CODE	COMPATIBLE DIMMING BALLAST
Daylight Sensor (DS)	Lutron	EC-DIR-WH	Daylight	LD	EcoSystem
	Wattstopper	FD-301	Daylight	WD	0-10V
	Philips	Luxsense	Daylight	PL	0-10V
Occupancy Sensor (OS)	Wattstopper	FS-205	PIR Occupancy	WP1	Programmed Rapid Start
		FS-355	PIR Occupancy	WP2	Programmed Rapid Start
		FM-105	High Frequency Occupancy	WH	Programmed Rapid Start
Daylight & Occupancy Sensors (DOS)	Philips	Actilume	Daylight & PIR Occupancy	PA	DALI or 0-10V

● **PHOTOMETRIC DATA**

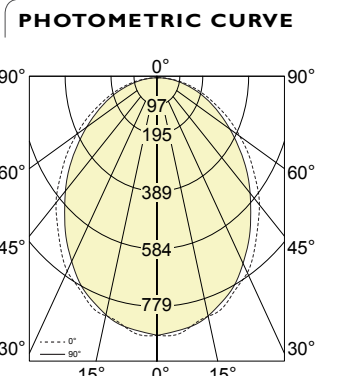
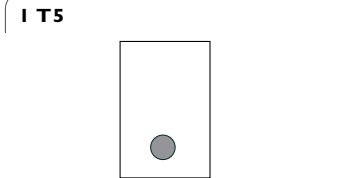

Test Lamp: 1xF28T5
 IES FILE: BD-S-4-T5-1

Efficiency: 47.2%

CANDELA DISTRIBUTION

Vertical Angle	Horizontal Angles					Zonal Lumens
	0	22.5	45	67.5	90	
0	486	486	486	486	486	
5	478	481	490	472	484	26
15	462	458	454	457	444	109
25	424	427	423	415	421	180
35	380	380	376	369	370	228
45	325	322	310	313	312	244
55	256	253	248	250	244	231
65	179	177	173	170	169	187
75	102	98	94	91	90	119
85	31	27	23	20	18	44
90	6	3	1	0	0	

LUMINANCE DATA (CD/M²)

Vertical Angle	Horizontal Angles		
	0	45	90
45	6157	2892	2443
55	5808	2314	1866
65	5252	1662	1296
75	4411	961	716
85	2745	255	157

COEFFICIENTS OF UTILIZATION (%)

Ceiling	80			70			50				
	70	50	30	10	70	50	30	10	50	30	10
Wall	70	50	30	10	70	50	30	10	50	30	10
0	56	56	56	56	55	55	55	55	53	53	53
1	51	49	47	45	50	48	46	44	46	44	43
2	47	43	39	37	45	42	39	36	40	38	35
3	43	37	34	30	41	37	33	30	35	32	30
4	39	33	29	26	38	33	29	26	31	28	25
5	36	30	25	22	35	29	25	22	28	24	22
6	33	27	22	19	32	26	22	19	25	22	19
7	31	24	20	17	30	24	20	17	23	19	17
8	28	22	18	15	28	22	18	15	21	18	15
9	27	20	16	14	26	20	16	14	19	16	14
10	25	19	15	12	24	18	15	12	18	15	12

Based on floor reflectance of 20

i All IES files for other lamping are available for download at: www.axislighting.com

● PHOTOMETRIC DATA

I T5

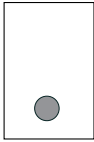

PHOTOMETRIC CURVE

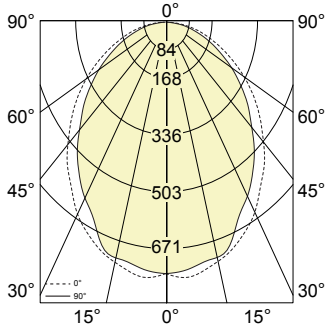

Test Lamp: IxF28T5
 IES FILE: BD-F-4-T5-1

Efficiency: 55.7%

CANDELA DISTRIBUTION

Vertical Angle	Horizontal Angles					Zonal Lumens
	0	22.5	45	67.5	90	
0	737	737	737	737	737	
5	750	739	729	755	728	40
15	702	689	675	676	692	166
25	616	598	585	576	564	256
35	504	495	474	453	452	295
45	389	375	355	340	339	285
55	281	268	255	238	237	242
65	180	175	161	152	149	179
75	100	94	86	80	77	109
85	32	28	23	19	18	42
90	5	4	1	0	1	

LUMINANCE DATA (CD/M²)

Vertical Angle	Horizontal Angles		
	0	45	90
45	7363	3305	2651
55	6363	2373	1811
65	5285	1547	1141
75	4328	882	617
85	2808	257	150

COEFFICIENTS OF UTILIZATION (%)

Ceiling	80			70			50				
	70	50	30	10	70	50	30	10	50	30	10
Wall	70	50	30	10	70	50	30	10	50	30	10
0	67	67	67	67	65	65	65	65	62	62	62
1	61	59	56	54	60	57	55	54	55	53	52
2	56	52	48	45	55	51	47	45	49	46	44
3	51	46	42	38	50	45	41	38	43	40	37
4	47	41	36	33	46	40	36	33	39	35	32
5	44	37	32	29	43	36	32	28	35	31	28
6	41	33	29	25	40	33	28	25	32	28	25
7	38	31	26	23	37	30	26	22	29	25	22
8	35	28	23	20	34	28	23	20	27	23	20
9	33	26	21	18	32	25	21	18	25	21	18
10	31	24	20	17	30	24	20	17	23	19	17

Based on floor reflectance of 20

I T5HO

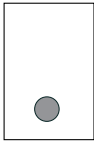

PHOTOMETRIC CURVE

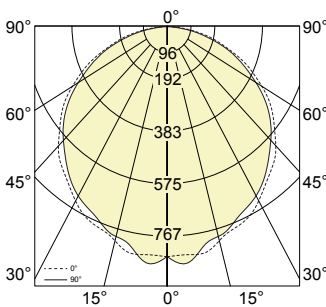

Test Lamp: IxF54T5HO
 IES FILE: BD-S-4-T5HO-1

Efficiency: 47.2%

CANDELA DISTRIBUTION

Vertical Angle	Horizontal Angles					Zonal Lumens
	0	22.5	45	67.5	90	
0	837	837	837	837	837	
5	833	819	815	834	863	45
15	790	789	787	785	781	189
25	740	736	735	715	712	311
35	651	653	644	641	631	391
45	554	557	540	533	534	420
55	445	437	430	426	420	399
65	311	307	300	294	289	322
75	174	169	163	158	155	206
85	52	47	40	32	32	76
90	10	6	2	1	1	

LUMINANCE DATA (CD/M²)

Vertical Angle	Horizontal Angles		
	0	45	90
45	10496	5026	4183
55	10082	4004	3204
65	9116	2879	2216
75	7542	1674	1233
85	4565	450	276

COEFFICIENTS OF UTILIZATION (%)

Ceiling	80			70			50				
	70	50	30	10	70	50	30	10	50	30	10
Wall	70	50	30	10	70	50	30	10	50	30	10
0	56	56	56	56	55	55	55	55	53	53	53
1	51	49	47	45	50	48	46	44	46	44	43
2	47	43	39	37	45	42	39	36	40	38	35
3	43	37	34	30	41	37	33	30	35	32	30
4	39	33	29	26	38	32	29	26	31	28	25
5	36	30	25	22	35	29	25	22	28	24	22
6	33	27	22	19	32	26	22	19	25	22	19
7	31	24	20	17	30	24	20	17	23	19	17
8	28	22	18	15	28	22	18	15	21	18	15
9	27	20	16	14	26	20	16	14	19	16	14
10	25	19	15	12	24	18	15	12	18	15	12

Based on floor reflectance of 20

i All IES files for other lamping are available for download at: www.axislighting.com

● PHOTOMETRIC DATA

I T8

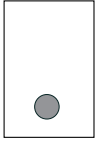

PHOTOMETRIC CURVE

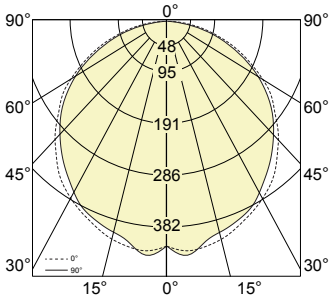

Test Lamp: IxF32T8

IES FILE: BD-S-4-T8-1

Efficiency: 41.9%

CANDELA DISTRIBUTION

Vertical Angle	Horizontal Angles					Zonal Lumens
	0	22.5	45	67.5	90	
0	411	411	411	411	411	
5	421	420	425	418	429	23
15	408	402	410	399	396	97
25	379	376	372	371	371	160
35	341	333	330	325	324	201
45	287	281	280	276	275	216
55	231	225	225	217	219	206
65	159	159	154	151	150	167
75	90	87	85	82	81	106
85	28	25	21	17	16	40
90	5	3	1	0	0	

COEFFICIENTS OF UTILIZATION (%)

Ceiling	80			70			50				
	70	50	30	10	70	50	30	10	50	30	10
Wall											
0	50	50	50	50	49	49	49	49	47	47	47
1	46	44	42	40	44	43	41	39	41	39	38
2	41	38	35	33	40	37	34	32	36	33	31
3	38	33	30	27	37	33	29	27	31	28	26
4	34	29	26	23	33	29	25	23	28	25	22
5	32	26	22	20	31	26	22	19	25	22	19
6	29	24	20	17	28	23	20	17	22	19	17
7	27	21	18	15	26	21	17	15	20	17	15
8	25	19	16	13	25	19	16	13	19	15	13
9	24	18	14	12	23	18	14	12	17	14	12
10	22	16	13	11	22	16	13	11	16	13	11

Based on floor reflectance of 20

LUMINANCE DATA (CD/M²)

Vertical Angle	Horizontal Angles		
	0	45	90
45	5267	2516	2079
55	5070	2022	1613
65	4532	1431	1116
75	3778	840	623
85	2446	231	133

I T8

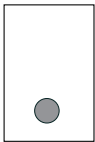

PHOTOMETRIC CURVE

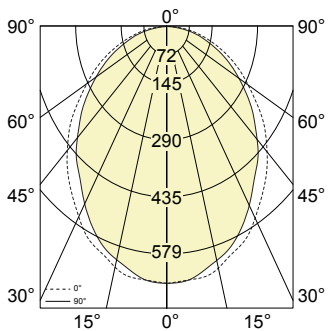

Test Lamp: IxF32T8

IES FILE: BD-F-4-T8-1

Efficiency: 49.6%

CANDELA DISTRIBUTION

Vertical Angle	Horizontal Angles					Zonal Lumens
	0	22.5	45	67.5	90	
0	652	652	652	652	652	
5	645	643	649	639	645	10
15	604	594	591	595	588	30
25	530	526	513	499	494	50
35	439	426	413	406	400	70
45	344	331	317	308	304	90
55	244	240	230	221	216	110
65	163	156	150	142	139	130
75	89	85	80	76	75	150
85	30	26	21	18	16	170
90	6	4	1	1	1	

COEFFICIENTS OF UTILIZATION (%)

Ceiling	80			70			50				
	70	50	30	10	70	50	30	10	50	30	10
Wall											
0	59	59	59	59	58	58	58	58	55	55	55
1	54	52	50	48	53	51	49	47	49	47	46
2	50	46	43	40	48	45	42	39	43	41	38
3	46	41	37	34	44	40	36	33	38	35	33
4	42	36	32	29	41	36	32	29	34	31	28
5	39	33	28	25	38	32	28	25	31	27	25
6	36	30	25	22	35	29	25	22	28	25	22
7	33	27	23	20	33	27	23	20	26	22	20
8	31	25	21	18	30	24	20	18	24	20	18
9	29	23	19	16	29	22	19	16	22	18	16
10	27	21	17	15	27	21	17	15	20	17	15

Based on floor reflectance of 20

LUMINANCE DATA (CD/M²)

Vertical Angle	Horizontal Angles		
	0	45	90
45	6304	2855	2301
55	5352	2072	1589
65	4632	1389	1031
75	3768	789	580
85	2576	230	135

i All IES files for other lamping are available for download at: www.axislighting.com