

● **PROJECT INFORMATION**

Project:

Type:

Notes:

● **DIMENSIONS**

SECTION VIEWS

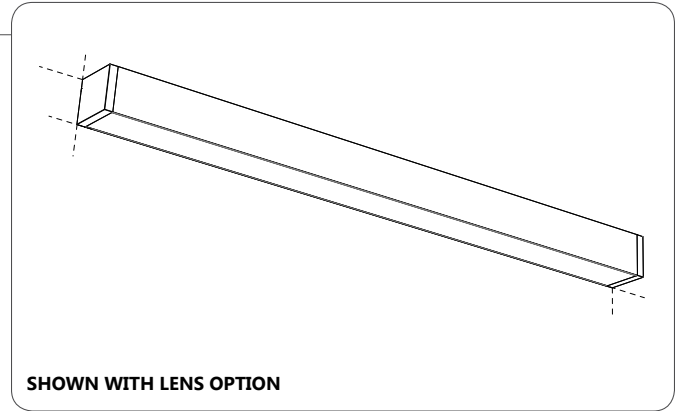
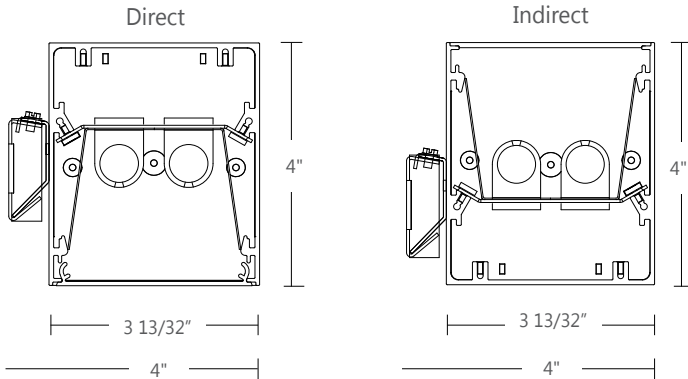

● **ORDERING CODE**

1	2	3	4	5	6	7	8	9	10	11	12	13	14	15
---	---	---	---	---	---	---	---	---	----	----	----	----	----	----

● **PRODUCT SPECIFICATIONS**

1	PRODUCT ID	2	OPTICS	3	LENGTH (FT)	4	SPECIFY LENGTH	5	LAMP	6	LAMP CONFIGURATION
BMWD	wall direct	S	satin lens	2	2'	NL	nominal (3' & 4' lamps)	T5	T5	0	0 lamp
BMWI	wall indirect	F	frosted lens ⁽²⁾	3	3'	NL4	nominal (4' lamps only)	T5HO	T5HO	1	1 lamp
BMWV	wall vertical ⁽¹⁾	PL	semi spec. para. louvers	4	4'	EX	exact (3' & 4' lamps)	T8	T8	2	2 lamps ⁽³⁾
		C	clear lens	5	5'	EX4	exact (4' lamps only)			+S	staggered ⁽⁴⁾
		NO	no lens	6	6'						
		B	blank	8	8'						
				12	12'						
				S#	System Run						
(1) Indirect lamping is not suggested for vertical mount		(2) not recommended with staggered lamping								(3) not available for T8 lamping (4) Staggered one T5/T5HO lamps only.	

7	MR	8	FINISH	9	VOLTAGE	10	BALLAST	11	CIRCUITS	12	BATTERY (OPTIONAL)
M16#	MR 16 halogen	AP	aluminum paint	120	120 V	D	dimming	1	1 regular	B#	battery pack 4' sections
M16LED#	MR 16 LED	W	white	277	277 V	E	instant start ⁽⁶⁾	2	2 regular		
		BLK	black	347	347 V ⁽⁵⁾	ERS	program start	2A/B	2 alternating		
		C	custom	UNV	universal	BI	bi-level dimming	+E(#)	emergency section		
								+NL(#)	night light section		
								+GTD(#)	generator transfer device		
								+M	MR		
Add 9" per lamp Requires 120V or 277V		(5) Please consult factory				(6) Available with T8 lamp only					

13	OTHER (OPTIONAL)	14	IC CONTROLS (OPTIONAL)	15	CUSTOM (OPTIONAL)
F	fuse	DS#	daylight sensor	C	custom
EF	end feed	OS#	occupancy sensor		
		DOS#	daylight&occupancy sensor		
			See integrated controls guide for further details	Please specify	

● CONSTRUCTION

Housing	Extruded Aluminum (0.075" nominal) up to 70% Recycled Content
End Cap	Sheet Steel (18 ga)
Interior Brackets	Die Formed Sheet Steel (18 ga)
Reflectors	White Powder Coated Sheet Steel (22 ga)
Louvers	Die Formed Semi-Specular Aluminum (22 ga)
Blank	Extruded Aluminum (0.075" nominal)
Lenses	Extruded Acrylic (0.070" nominal) Satin: 68% trans. Frosted: 85% trans.

Wall Mount Bracket Die Formed Sheet Steel (16 gauge)

Vertical Wall Mount Bracket Die Formed Sheet Steel (18 gauge)

● WEIGHT

4 ft	12.3 lbs / 5.0 kg
8 ft	24.6 lbs / 10.1 kg
12 ft	36.9 lbs / 15.1 kg

● SYSTEM (S#)

BEAM 3 linear systems, with the use of a strong profile, allow for a nearly hair thin connection system of continuous runs. Lengths of 4', 8', 12' as well as custom lengths are available. Runs of BEAM 3 that are greater than 12' in length are designated as systems (S#). This means that the run is comprised of a combination 4', 8' and/or 12' sections to be assembled on site using our joining system. For more information on systems and joining, please refer to the BEAM installation sheets available for download at www.axislighting.com.

● ELECTRICAL

Ballast Electronic IS, Electronic Rapid Start, Dimming (0-10V, Line, EcoSystem, DALI), with preinstalled ballast disconnect as per NEC & CEC, BI-level dimming

Emergency Emergency battery pack or emergency circuit

Voltage 120V, 277V, 347V, UNV

i Incorporating these components may have limitations or effect the length of the luminaire, please contact factory for more details.

● FINISH

Aluminium paint, Powder Coated and custom finishes are also available.

● APPROVALS

Certified to UL and CUL standards 
 Meets NYC and ADA requirements
 Suitable for damp locations.

● JOINERS

In order to allow very long runs of BEAM 3 luminaires, Axis has developed a number of different joining systems. Special care has been taken to maximize the performance of the joiner for each BEAM option.

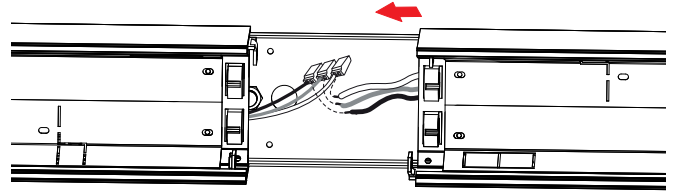

NOTE: Mount each system segment individually. Do not assemble system prior to mounting.

i Allow a minimum of 6" between end of long runs and vertical wall

● STAGGERED LAMPING

When BEAM 3 is used in continuous runs longer than 4', staggered lamping can be used to eliminate the appearance of socket shadows at the ends of the lamps. BEAM 3 uses a staggered overlap of 4 different bracket lengths (3.5", 4", 4.5" and 5"), along with 3' and 4' lamps, allowing us to match almost any row length requirements with optimal results. For example 3 x 3' T5 lamps can be used to completely illuminate the lens of an 8' luminaire.

LAMP TYPE	T5	T5HO
1 lamp	•	•

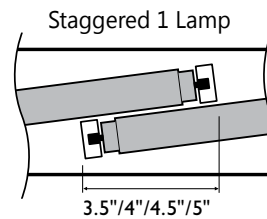

● **OPTICS**

Satin & Frosted Lens - (acrylic snap-in lens)

satin: 68% trans.
 frosted: 85% trans.

Semi-spec. parabolic louver

9/16" deep blades – 5/8" spacing
 72 blades per 4'



S satin lens

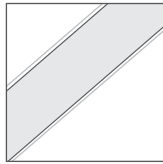

F frosted lens

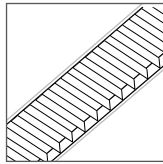

PL semi-specular parabolic louvers

● **CORNERS**

Unlit Corners - BEAM3

features a multitude of layout patterns with the use of a number of corners, 90° corner, T or X junctions.

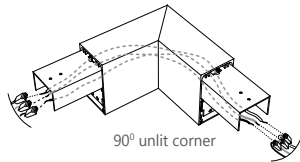

90° unlit corner

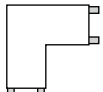

90° corner

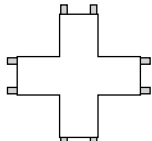

X junction

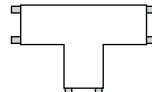

T junction

Lit Corners - In addition Axis offers Lit 90° Corners including Ceiling to Ceiling, Wall to Ceiling and Ceiling to Wall.

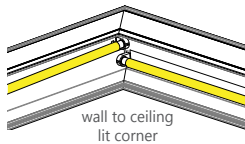

wall to ceiling lit corner

i For custom corner angles, please consult factory. Specifications sheets for all corners are available at: www.axislighting.com

● **MR16**

Blank MR16 Halogens MR16 LED Quantity

Extruded Aluminum (0.075" nominal)
 2.0" diameter (35W / 50W)
 2.0" diameter

For every 4' fluorescent lamp section, there may be up to a maximum of 4 x MR16 lamps.

Spacing

Each MR16 is placed centered on a blank section 9" in length.

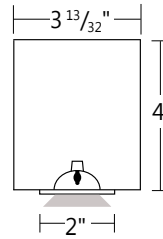

For a series of MR16's within a given section length, they will be spaced evenly on a longer blank section. The directed light of MR16 Halogen lamps are fixed downward.

Custom spacing may be available on special request. *Please consult factory

Between fluorescent lamps sections

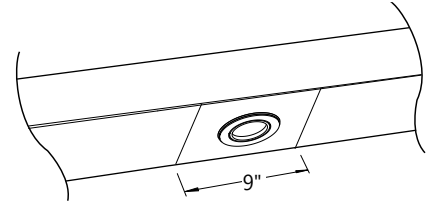

At luminaire ends

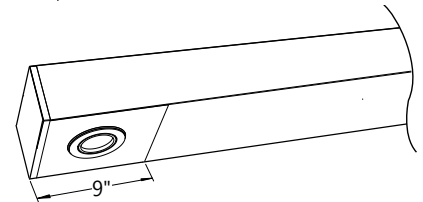

Several in a long blank section

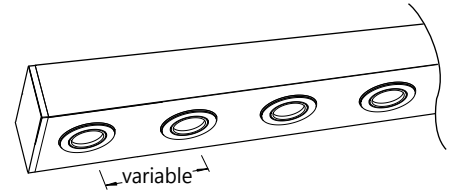

● **MOUNTING SPACING**

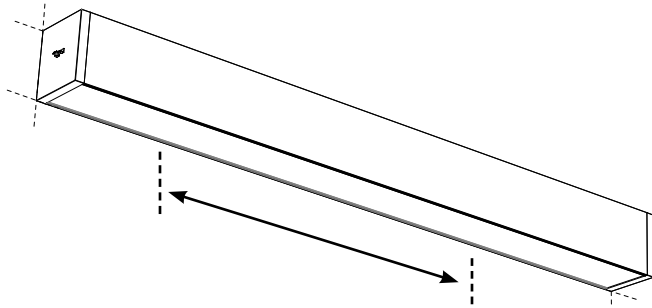

STAGGERED

1 LAMP

T5/T5HO

BEAM3 8' (64" C.C.)

BEAM3 12' (112" C.C.)

2 LAMPS

T5/T5HO

BEAM3 4' (32" C.C.)

BEAM3 8' (80" C.C.)

BEAM3 12' (128" C.C.)

END TO END

T5/T5HO

BEAM3 4' (32" C.C.)

BEAM3 8' (80" C.C.)

BEAM3 12' (112" C.C.)

T8

BEAM3 4' (32" C.C.)

BEAM3 8' (80" C.C.)

BEAM3 12' (128" C.C.)

NOTE: Use stud if possible for mounting

● **HORIZONTAL MOUNTING DETAILS**

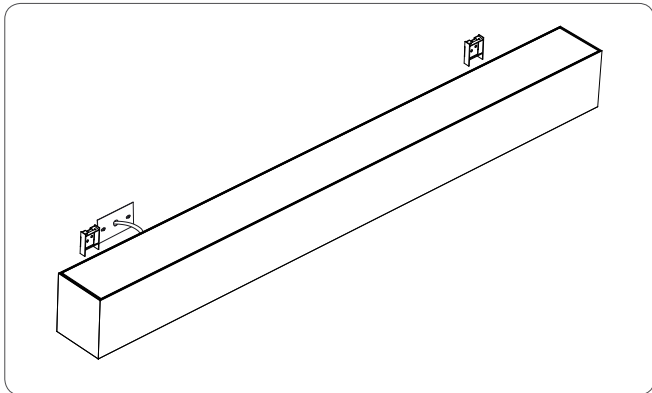

MOUNTING BRACKETS

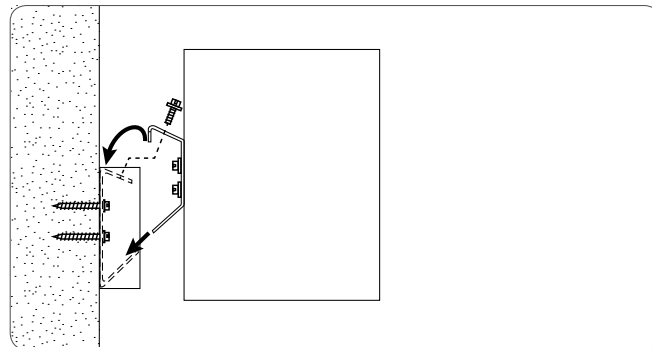

SIDE VIEW

● **VERTICAL MOUNTING DETAILS**

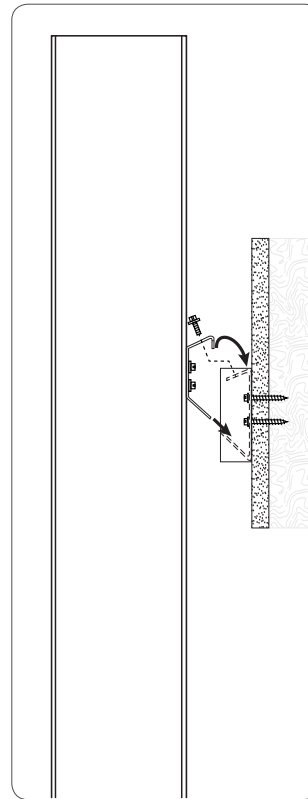

MOUNTING BRACKETS

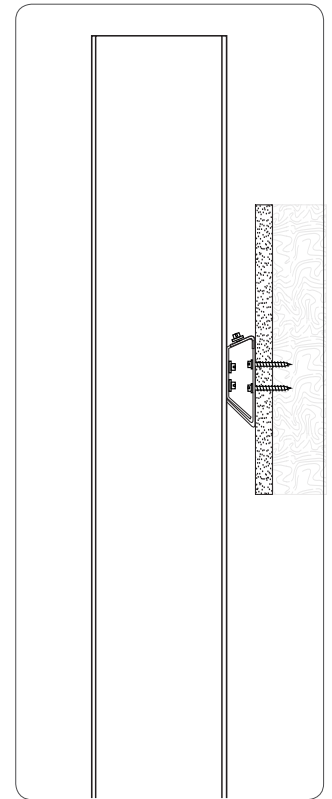

SIDE VIEW

● **OTHER MOUNTING OPTIONS**

BEAM 3 is available with recessed, pendant, surface, wall, asymmetric, recessed wall and wall wash mounted options.

i Specification sheets and Installation sheets for all mounting for BEAM luminaires are available for download at www.axislighting.com

● **INTEGRATED CONTROL OPTIONS**

BEAM 3 luminaires allow the use of integrated controls such as daylight sensors (DS), occupancy sensors (OS) and combination daylight/occupancy sensors (DOS). These options can be seamlessly integrated into our luminaires. The control system could be used to optimize the lighting of the space by reducing energy consumption through daylight harvesting and occupancy, thereby improving the overall interior environment and allowing for LEED credits.

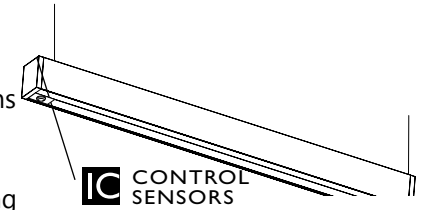

- Consult factory for other options.

SENSORS	BRAND	Model	TYPE	CODE	COMPATIBLE DIMMING BALLAST
Daylight Sensor (DS)	Lutron	EC-DIR-WH	Daylight	LD	EcoSystem
	Wattstopper	FD-301	Daylight	WD	0-10V
	Philips	Luxsense	Daylight	PL	0-10V
Occupancy Sensor (OS)	Wattstopper	FS-205	PIR Occupancy	WP1	Programmed Rapid Start
		FS-355	PIR Occupancy	WP2	Programmed Rapid Start
		FM-105	High Frequency Occupancy	WH	Programmed Rapid Start
Daylight & Occupancy Sensors (DOS)	Philips	Actilume	Daylight & PIR Occupancy	PA	DALI or 0-10V

● **PHOTOMETRIC DATA**

I T5

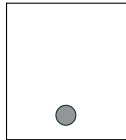

PHOTOMETRIC CURVE

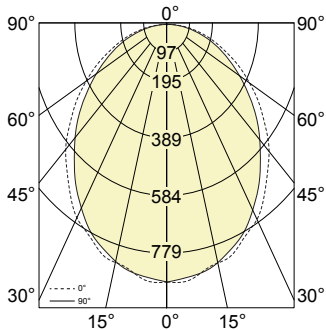

Test Lamp: 1xF28T5
 IES FILE: BMD-F-4-T5-1

Efficiency: 68.4 %

CANDELA DISTRIBUTION

Vertical Angle	Horizontal Angles					Zonal Lumens
	0	22.5	45	67.5	90	
0	875	875	875	875	875	
5	872	876	864	870	861	47
15	818	826	808	806	801	195
25	726	713	706	685	690	306
35	596	591	572	555	551	356
45	465	455	440	421	421	349
55	337	329	315	303	296	300
65	218	218	205	197	194	226
75	124	119	116	108	105	142
85	42	40	36	33	32	60
90	5	4	3	2	2	

LUMINANCE DATA (CD/M²)

Vertical Angle	Horizontal Angles		
	0	45	90
45	5775	3083	2556
55	4986	2256	1794
65	4154	1551	1212
75	3435	955	694
85	2280	339	230

COEFFICIENTS OF UTILIZATION (%)

Ceiling	80			70			50				
	70	50	30	10	70	50	30	10	50	30	10
Wall	70	50	30	10	70	50	30	10	50	30	10
0	82	82	82	82	80	80	80	80	76	76	76
1	75	72	69	66	73	70	68	65	67	65	63
2	68	63	59	55	67	62	58	54	59	56	53
3	63	56	50	46	61	55	50	46	53	48	45
4	58	50	44	40	56	49	43	39	47	42	39
5	53	45	39	34	52	44	38	34	43	38	34
6	49	41	35	30	48	40	34	30	39	34	30
7	46	37	31	27	45	36	31	27	35	30	27
8	43	34	28	24	42	33	28	24	33	28	24
9	40	31	26	22	39	31	26	22	30	25	22
10	38	29	24	20	37	29	24	20	28	23	20

Based on floor reflectance of 20

i All IES files for other lampping are available for download at: www.axislighting.com

● **PHOTOMETRIC DATA**

2 T5

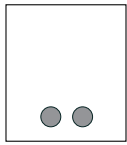

PHOTOMETRIC CURVE

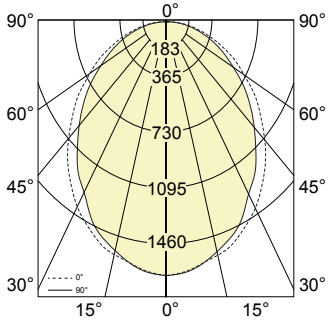

Test Lamp: 2x F28T5

IES FILE: BMD-F-4-T5-2

Efficiency: 62.5%

CANDELA DISTRIBUTION

Vertical Angle	Horizontal Angles					Zonal Lumens
	0	22.5	45	67.5	90	
0	1643	1643	1643	1643	1643	
5	1615	1597	1599	1596	1621	86
15	1520	1506	1496	1495	1479	362
25	1342	1319	1291	1270	1241	563
35	1110	1081	1046	1004	1001	652
45	855	843	795	773	758	638
55	613	604	572	542	531	545
65	405	399	373	357	350	411
75	223	221	206	196	192	258
85	78	72	65	58	58	109
90	10	7	5	3	3	

COEFFICIENTS OF UTILIZATION (%)

Ceiling	80			70			50				
	70	50	30	10	70	50	30	10	50	30	10
Wall	70	50	30	10	70	50	30	10	50	30	10
0	75	75	75	75	73	73	73	73	70	70	70
1	68	66	63	61	67	64	62	60	62	60	58
2	63	58	54	50	61	56	53	50	54	51	48
3	57	51	46	42	56	50	46	42	48	44	41
4	53	46	40	36	51	45	40	36	43	39	36
5	49	41	36	32	47	40	35	31	39	35	31
6	45	37	32	28	44	37	31	28	35	31	27
7	42	34	29	25	41	33	28	25	32	28	25
8	39	31	26	22	38	31	26	22	30	25	22
9	37	29	24	20	36	28	23	20	28	23	20
10	35	27	22	19	34	26	22	18	26	21	18

Based on floor reflectance of 20

LUMINANCE DATA (CD/M²)

Vertical Angle	Horizontal Angles		
	0	45	90
45	10617	5573	4605
55	9079	4095	3214
65	7712	2817	2182
75	6199	1700	1269
85	4294	616	421

1 T5

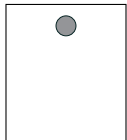

PHOTOMETRIC CURVE

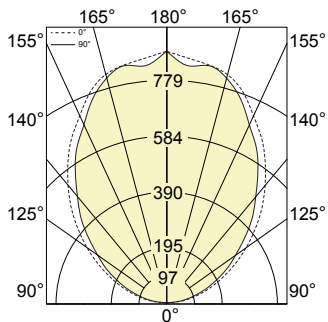

Test Lamp: 1x F28T5

IES FILE: BMI-F-4-T5-1

Efficiency: 68.4%

CANDELA DISTRIBUTION

Vertical Angle	Horizontal Angles					Zonal Lumens
	0	22.5	45	67.5	90	
90	11	8	5	4	3	
95	43	40	36	32	32	60
105	122	119	116	110	105	142
115	221	218	208	199	194	227
125	339	327	315	303	294	300
135	469	457	437	426	422	349
145	598	592	576	556	553	356
155	716	710	704	684	682	305
165	823	816	808	798	809	195
175	856	874	866	861	830	46
180	877	877	877	877	877	

COEFFICIENTS OF UTILIZATION (%)

Ceiling	80			70			50				
	70	50	30	10	70	50	30	10	50	30	10
Wall	70	50	30	10	70	50	30	10	50	30	10
0	65	65	65	65	56	56	56	56	38	38	38
1	59	57	54	52	51	48	47	45	33	32	31
2	54	49	46	42	46	42	39	37	29	27	26
3	49	43	39	35	42	37	33	30	25	23	21
4	45	38	33	29	38	33	29	26	23	20	18
5	41	34	29	25	35	29	25	22	20	17	15
6	38	30	25	21	32	26	22	19	18	15	13
7	35	27	22	18	29	23	19	16	16	13	11
8	32	24	19	16	27	21	17	14	14	12	10
9	29	22	17	14	25	19	15	12	13	10	9
10	27	20	15	12	23	17	13	11	12	9	8

Based on floor reflectance of 20

i All IES files for other lamping are available for download at: www.axislighting.com

● PHOTOMETRIC DATA

1 T5HO

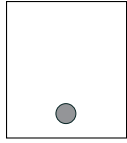

PHOTOMETRIC CURVE

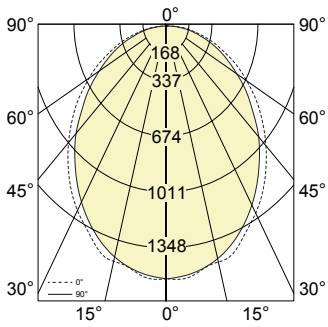

Test Lamp: 1x**F54T5HO**
 IES FILE: BMD-F-4-T5HO-1

Efficiency: 68.4%

CANDELA DISTRIBUTION

Vertical Angle	Horizontal Angles					Zonal Lumens
	0	22.5	45	67.5	90	
0	1513	1513	1513	1513	1513	
5	1510	1516	1496	1499	1493	81
15	1432	1397	1388	1391	1384	337
25	1242	1230	1210	1186	1190	527
35	1028	1015	984	957	960	614
45	802	785	757	735	722	603
55	583	565	545	516	512	517
65	381	374	358	342	337	390
75	210	206	198	186	181	244
85	75	69	61	57	53	104
90	10	7	5	3	3	

COEFFICIENTS OF UTILIZATION (%)

Ceiling	80			70			50				
	70	50	30	10	70	50	30	10	50	30	10
Wall	70	50	30	10	70	50	30	10	50	30	10
0	82	82	82	82	80	80	80	80	76	76	76
1	75	72	69	66	73	70	68	65	67	65	63
2	68	63	59	55	67	62	58	54	59	56	53
3	63	56	50	46	61	55	50	46	53	48	45
4	58	50	44	40	56	49	43	39	47	42	39
5	53	45	39	34	52	44	38	34	43	38	34
6	49	41	35	30	48	40	34	30	39	34	30
7	46	37	31	27	45	36	31	27	35	30	27
8	43	34	28	24	42	33	28	24	33	28	24
9	40	31	26	22	39	31	26	22	30	25	22
10	38	29	24	20	37	29	23	20	28	23	20

Based on floor reflectance of 20

LUMINANCE DATA (CD/M²)

Vertical Angle	Horizontal Angles		
	0	45	90
45	9964	5307	4383
55	8628	3900	3101
65	7241	2703	2100
75	5848	1634	1197
85	4078	580	387

2 T5HO

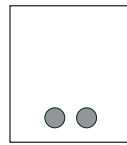

PHOTOMETRIC CURVE

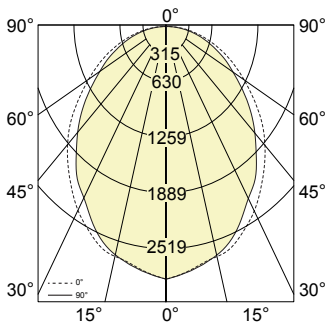

Test Lamp: 2x**F54T5HO**
 IES FILE: BMD-F-4-T5HO-2

Efficiency: 62.5%

CANDELA DISTRIBUTION

Vertical Angle	Horizontal Angles					Zonal Lumens
	0	22.5	45	67.5	90	
0	2831	2831	2831	2831	2831	
5	2753	2769	2722	2834	2761	149
15	2606	2594	2557	2558	2552	620
25	2297	2277	2211	2183	2142	968
35	1901	1882	1802	1740	1740	1127
45	1495	1455	1384	1321	1313	1103
55	1059	1039	983	941	908	938
65	706	681	649	606	599	707
75	390	376	361	340	334	445
85	135	129	111	102	97	189
90	18	13	8	5	5	

COEFFICIENTS OF UTILIZATION (%)

Ceiling	80			70			50				
	70	50	30	10	70	50	30	10	50	30	10
Wall	70	50	30	10	70	50	30	10	50	30	10
0	75	75	75	75	73	73	73	73	70	70	70
1	68	66	63	61	67	64	62	60	62	60	58
2	63	58	54	50	61	56	53	50	54	51	48
3	57	51	46	42	56	50	46	42	48	44	41
4	53	46	40	36	51	45	40	36	43	39	36
5	49	41	36	32	47	40	35	31	39	35	31
6	45	37	32	28	44	37	31	28	35	31	27
7	42	34	29	25	41	33	28	25	32	28	25
8	39	31	26	22	38	31	26	22	30	25	22
9	37	29	24	20	36	28	23	20	28	23	20
10	35	27	22	18	34	26	22	18	26	21	18

Based on floor reflectance of 20

LUMINANCE DATA (CD/M²)

Vertical Angle	Horizontal Angles		
	0	45	90
45	18569	9700	7973
55	15670	7042	5498
65	13431	4904	3732
75	10844	2982	2210
85	7402	1050	709

i All IES files for other lamping are available for download at: www.axislighting.com

● **PHOTOMETRIC DATA**

I T5HO

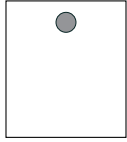

PHOTOMETRIC CURVE

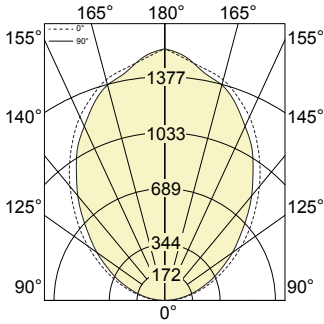

Test Lamp: IxF54T5HO

IES FILE: BMI-F-4-T5HO-1

Efficiency: 68.4%

CANDELA DISTRIBUTION

Vertical Angle	Horizontal Angles					Zonal Lumens
	0	22.5	45	67.5	90	
90	9	7	4	3	3	
95	73	69	62	56	53	37
105	211	209	199	188	184	175
115	381	374	356	339	337	319
125	581	564	542	515	515	456
135	800	789	756	731	721	567
145	1031	1021	987	952	957	618
155	1248	1235	1203	1191	1183	584
165	1406	1399	1394	1386	1373	444
175	1492	1507	1495	1486	1505	210
180	1549	1549	1549	1549	1549	

COEFFICIENTS OF UTILIZATION (%)

Ceiling	80			70			50				
	70	50	30	10	70	50	30	10	50	30	10
Wall	70	50	30	10	70	50	30	10	50	30	10
0	65	65	65	65	56	56	56	56	38	38	38
1	59	57	54	52	51	48	46	45	33	32	31
2	54	49	46	42	46	42	39	37	29	27	26
3	49	43	39	35	42	37	33	30	25	23	21
4	45	38	33	29	38	33	29	26	22	20	18
5	41	34	29	25	35	29	25	22	20	17	15
6	38	30	25	21	32	26	22	19	18	15	13
7	35	27	22	18	29	23	19	16	16	13	11
8	32	24	19	16	27	21	17	14	14	12	10
9	29	22	17	14	25	19	15	12	13	10	9
10	27	20	15	12	23	17	13	11	12	9	8

Based on floor reflectance of 20

I T8

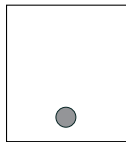

PHOTOMETRIC CURVE

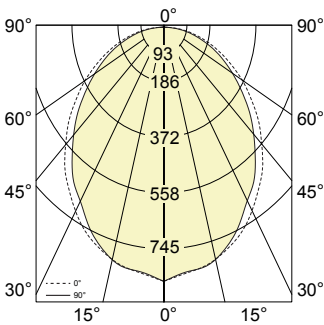

Test Lamp: IxF32T8

IES FILE: BMD-F-4-T8-1

Efficiency: 64.6%

CANDELA DISTRIBUTION

Vertical Angle	Horizontal Angles					Zonal Lumens
	0	22.5	45	67.5	90	
0	838	838	838	838	838	
5	815	814	812	814	811	44
15	767	765	761	754	762	184
25	677	674	661	651	641	288
35	566	554	543	526	523	337
45	441	431	416	403	398	331
55	320	310	299	286	282	284
65	210	205	197	187	187	214
75	117	114	108	105	102	135
85	40	39	34	31	30	57
90	5	4	3	2	2	

COEFFICIENTS OF UTILIZATION (%)

Ceiling	80			70			50				
	70	50	30	10	70	50	30	10	50	30	10
Wall	70	50	30	10	70	50	30	10	50	30	10
0	77	77	77	77	75	75	75	75	72	72	72
1	71	68	65	63	69	66	64	62	64	62	60
2	65	60	55	52	63	58	54	51	56	53	50
3	59	53	48	44	58	52	47	43	50	46	42
4	54	47	42	37	53	46	41	37	45	40	37
5	50	42	37	32	49	42	36	32	40	36	32
6	47	38	33	29	45	38	32	28	37	32	28
7	43	35	29	25	42	34	29	25	33	29	25
8	40	32	27	23	39	32	26	23	31	26	23
9	38	29	24	21	37	29	24	21	28	24	21
10	36	27	22	19	35	27	22	19	26	22	19

Based on floor reflectance of 20

LUMINANCE DATA (CD/M²)

Vertical Angle	Horizontal Angles		
	0	45	90
45	5449	2904	2406
55	4718	2129	1697
65	3972	1478	1157
75	3234	887	670
85	2198	323	218

i All IES files for other lamping are available for download at: www.axislighting.com

● PHOTOMETRIC DATA

I T8

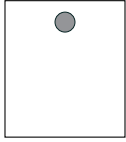

PHOTOMETRIC CURVE

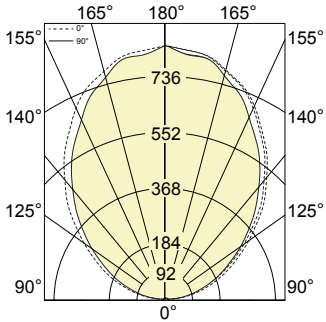

Test Lamp: IxF32T8

IES FILE: BMI-F-4-T8-1

Efficiency: 64.6%

CANDELA DISTRIBUTION

Vertical Angle	Horizontal Angles					Zonal Lumens
	0	22.5	45	67.5	90	
90	5	4	3	2	1	
95	39	38	35	31	31	21
105	116	113	109	102	100	96
115	211	205	196	190	186	176
125	317	310	300	287	285	251
135	444	431	413	403	402	312
145	566	556	540	529	525	339
155	682	672	660	649	639	319
165	766	766	755	756	745	242
175	814	816	821	828	799	115
180	826	826	826	826	826	

COEFFICIENTS OF UTILIZATION (%)

Ceiling	80			70			50				
	70	50	30	10	70	50	30	10	50	30	10
Wall	70	50	30	10	70	50	30	10	50	30	10
0	62	62	62	62	53	53	53	53	36	36	36
1	56	54	51	49	48	46	44	42	31	30	29
2	51	47	43	40	43	40	37	35	27	26	24
3	47	41	37	33	40	35	32	29	24	22	20
4	42	36	31	28	36	31	27	24	21	19	17
5	39	32	27	24	33	27	23	21	19	16	14
6	36	28	24	20	30	24	20	18	17	14	12
7	33	25	21	17	28	22	18	15	15	13	11
8	30	23	18	15	26	20	16	13	14	11	9
9	28	21	16	13	24	18	14	11	12	10	8
10	26	19	14	12	22	16	12	10	11	9	7

Based on floor reflectance of 20

i All IES files for other lamping are available for download at: www.axislighting.com