

● PROJECT INFORMATION

Project:

Type:

Notes:

● DIMENSIONS

SECTION VIEWS

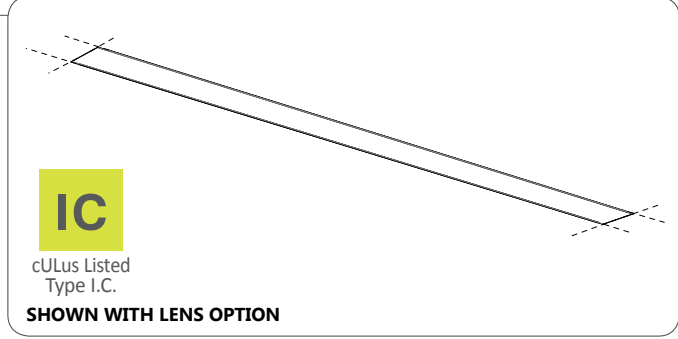
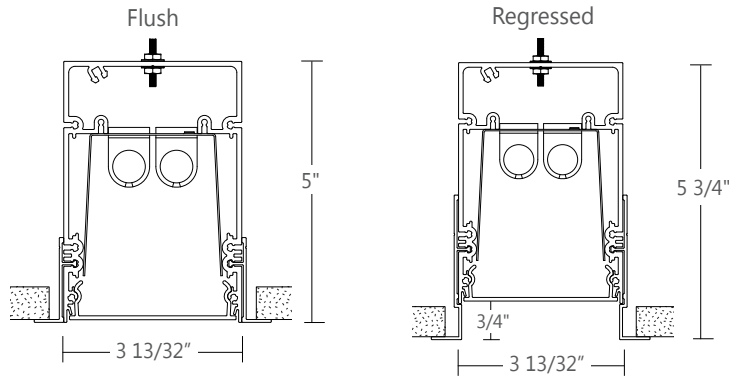

TECHZONE™ AND LOGIX™ COMPATIBLE
 for more info see page 3

● ORDERING CODE

1	2	3	4	5	6	7	8	9	10	11	12	13	14	15	16	17
---	---	---	---	---	---	---	---	---	----	----	----	----	----	----	----	----

● PRODUCT SPECIFICATIONS

1 PRODUCT ID	2 OPTICS	3 OPTICS POSITION	4 LENGTH (FT)	5 SPECIFY LENGTH	6 LAMP
BMR recessed	S satin lens F frosted lens PL semi spec. para. Louvers ⁽¹⁾ B blank	FL flush RG regressed	2 2' 3 3' 4 4' 5 5' 6 6' 8 8' 12 12' S# System Run	NL nominal (3' & 4' lamps) NL4 nominal (4' lamps only) EX exact (3' & 4' lamps) EX4 exact (4' lamps only)	T5 T5 T5HO T5HO T8 T8
(1) please consult factory					

7 LAMP CONFIGURATION	8 MR	9 FINISH	10 VOLTAGE	11 BALLAST	12 CIRCUITS
0 0 lamp 1 1 lamp 2 2 lamps ⁽²⁾ +S staggered ⁽³⁾	M16# MR 16 halogen M16LED# MR 16 LED	W white C custom	120 120 V 277 277 V 347 347 V ⁽⁴⁾ UNV universal	D dimming E instant start ⁽⁵⁾ ERS program start BI bi-level dimming	1 1 regular 2 2 regular 2A/B 2 alternating +E(#) emergency section +NL(#) night light section +GTD(#) generator transfer device +M MR
(2) Not available for T8 lamping. (3) Staggered one T5/T5HO lamps only.	Add 9" per lamp Requires 120V or 277V		(4) Please consult factory	(5) Available with T8 lamp only	

13 MOUNTING/SUSPENSION	14 BATTERY (OPTIONAL)	15 OTHER (OPTIONAL)	16 IC CONTROLS (OPTIONAL)	17 CUSTOM (OPTIONAL)
TB9 t-bar 9/16" TB15 t-bar 15/16" ST screw slot t-bar TG9 tegular 9/16" TG15 tegular 15/16" DF drywall flange D drywall flangeless DB slip-through bracket DS drywall spackle flange	B# battery pack 4' sections	F fuse EF end feed FW(#) flex whip (6' std) CP Chicago plenum AR air return plate ⁽⁶⁾ SR sprinkler plate ⁽⁶⁾ SPK speaker plate ⁽⁶⁾	DS# daylight sensor OS# occupancy sensor DOS# daylight&occupancy sensor	C custom
		(6) Please consult factory	See integrated controls guide for further details	Please specify

FILE NAME: BMR.SPEC March 10, 2016

● **CONSTRUCTION**

Housing	Extruded Aluminum (0.095" nominal) up to 70% Recycled Content
Interior Brackets	Die Formed Sheet Steel (18 ga)
Reflectors	White Powder Coated Sheet Steel (22 ga)
Blank	Extruded Aluminum (0.075" nominal)
Lenses	Extruded Acrylic (0.070" nominal) Satin: 68% trans. Frosted: 85% trans.
T-Bar Bracket	Die Formed Sheet Steel (16 ga)
Screw Slot T-Bar Bracket	Die Formed Sheet Steel (16 ga)
Slip-Through Bracket	Die Formed Sheet Steel (18 ga)
Spackle Flange	Die Formed Perforated Sheet Steel (20 ga)
Flange	Extruded Aluminum (0.075" nominal) visible flange width: 9/16"

● **WEIGHT**

4 ft	12.3 lbs / 5.0 kg
8 ft	24.6 lbs / 10.1 kg
12 ft	36.9 lbs / 15.1 kg

● **SYSTEM (S#)**

BEAM 3 linear systems, with the use of a strong profile, allow for a nearly hair thin connection system of continuous runs. Lengths of 4', 8', 12' as well as custom lengths are available. Runs of BEAM 3 that are greater than 12' in length are designated as systems (S#). This means that the run is comprised of a combination 4', 8' and/or 12' sections to be assembled on site using our joining system. For more information on systems and joining, please refer to the BEAM installation sheets available for download at www.axislighting.com.

● **ELECTRICAL**

Ballast	Electronic IS, Electronic Rapid Start, Dimming (0-10V, Line, EcoSystem, DALI), BI-level dimming With preinstalled ballast disconnect as per NEC & CEC
Emergency	Emergency battery pack or emergency circuit
Voltage	120V, 277V, 347V, UNV

i Incorporating these components may have limitations or effect the length of the luminaire, please contact factory for more details.

● **FINISH**

Powder Coated and custom finishes are also available.

● **APPROVALS**

Certified to UL and CUL standards 
 Meets NYC requirements
 Meets CCEC requirements (Chicago plenum)
 Suitable for damp locations.
 IC Rated (Insulated ceiling)

● **JOINERS**

In order to allow very long runs of BEAM 3 luminaires, Axis has developed a number of different joining systems. Special care has been taken to maximize the performance of the joiner for each BEAM option.

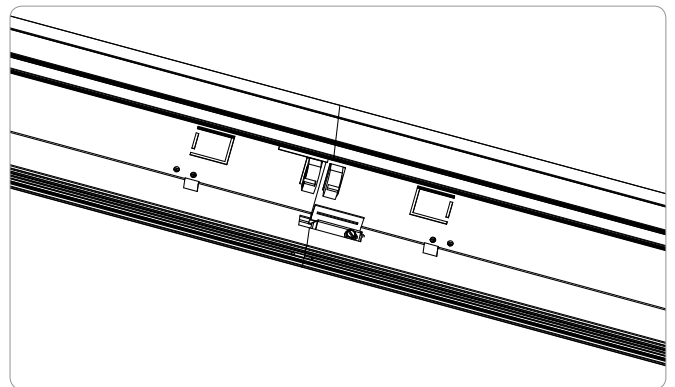
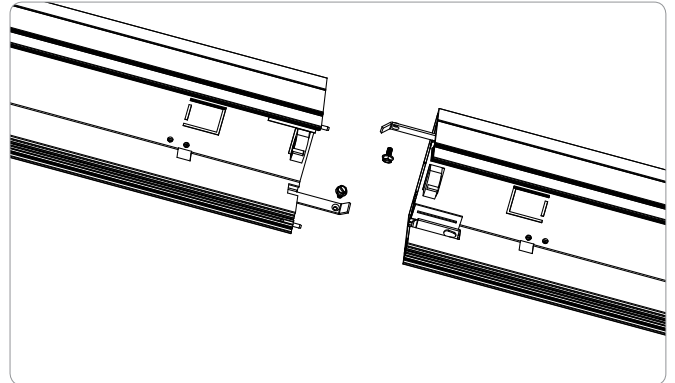

TB JOINER

NOTE: Hang each system segment individually. Do not assemble system prior to hanging.

● **STAGGERED LAMPING**

When BEAM 3 is used in continuous runs longer than 4', staggered lamping can be used to eliminate the appearance of socket shadows at the ends of the lamps. BEAM 3 uses a staggered overlap of 4 different bracket lengths (3.5", 4", 4.5" and 5"), along with 3' and 4' lamps, allowing us to match almost any row length requirements with optimal results. For example 3 x 3' T5 lamps can be used to completely illuminate the lens of an 8' luminaire.

LAMP TYPE	T5	T5HO
1 lamp	●	●

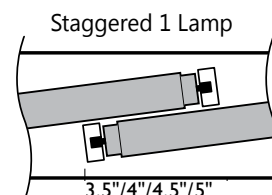

● **OPTICS**

Satin & Frosted Lens - (acrylic snap-in lens)

satin: 68% trans.
 frosted: 85% trans.

Semi-spec. parabolic louver

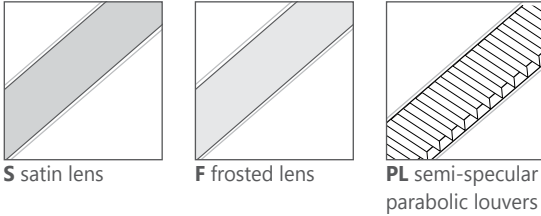

● **CORNERS - ONLY AVAILABLE WITH 4 3/4" EXTRUSION**

Unlit Corners - BEAM3 features a multitude of layout patterns with the use of a number of corners, 90° corner, T or X junctions.

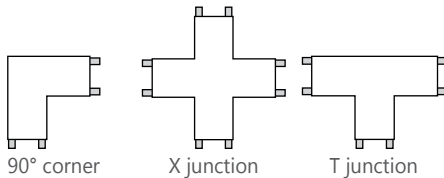
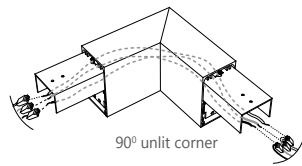

Lit Corners - In addition Axis offers Lit 90° Corners including Ceiling to Ceiling, Wall to Ceiling and Ceiling to Wall.

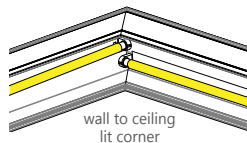

i Specifications sheets for all corners are available at: www.axislighting.com

● **TECHZONE™ AND LOGIX™**

Integrated contiguous modules for PA speakers, Air Returns and Sprinkler Heads are available for our recessed Beam products to add a consistent linear system to complete the illuminated portion.



● **MR16**

Blank MR16 Halogens MR16 LED Quantity

Extruded Aluminum (0.075" nominal)
 2.0" diameter (35W / 50W)
 2.0" diameter

For every 4' fluorescent lamp section, there may be up to a maximum of 4 x MR16 lamps.

Spacing

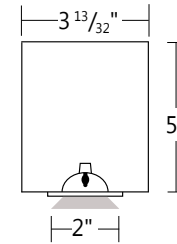

Each MR16 is placed centered on a blank section 9" in length.

For a series of MR16's within a given section length, they will be spaced evenly on a longer blank section. The directed light of MR16 Halogen lamps are fixed downward.

Custom spacing may be available on special request. *Please consult factory

Between fluorescent lamps sections

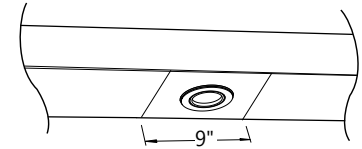

At luminaire ends

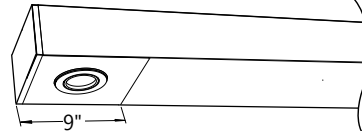

Several in a long blank section

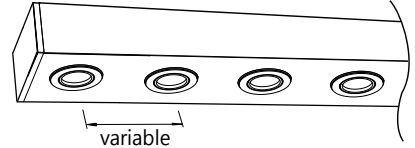

● **TB CEILING MOUNTING OPTIONS**

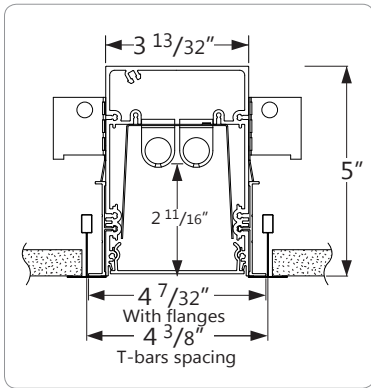

TB15 15/16" T-BAR

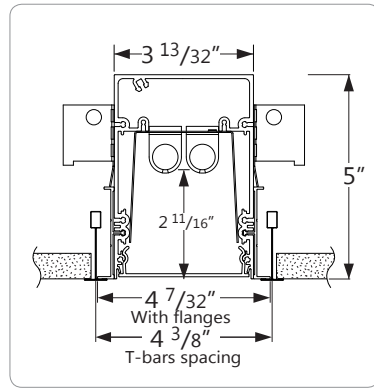

TB9 9/16" T-BAR

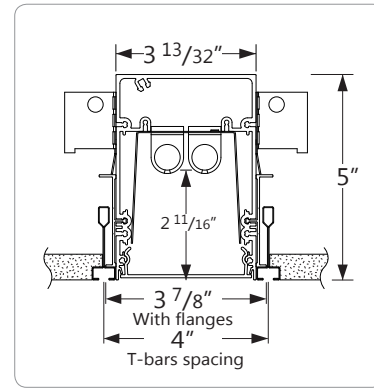

ST SCREW SLOT T-BAR

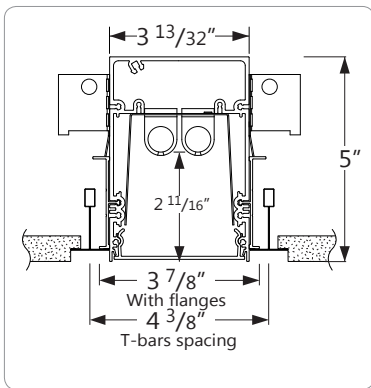

TG15 15/16" TEGULAR

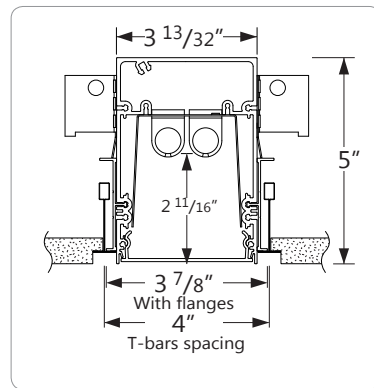

TG9 9/16" TEGULAR

● **DRYWALL CEILING MOUNTING OPTIONS**

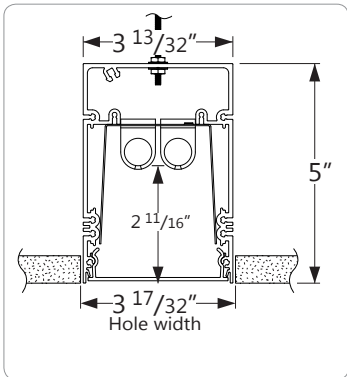

D FLANGELESS WITH 1/4-20 STUD MOUNTING

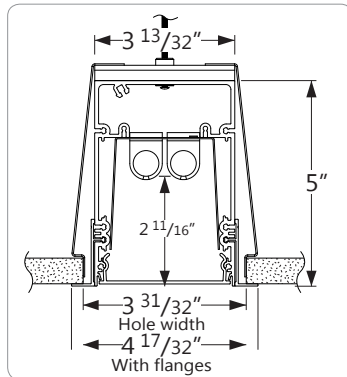

DB VISIBLE FLANGES WITH SLIP-THROUGH BRACKET

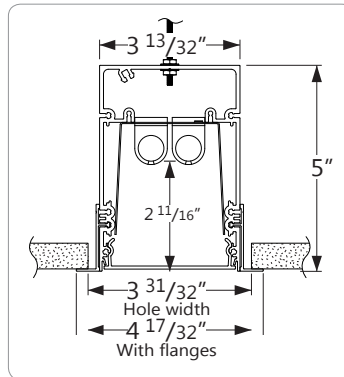

DF VISIBLE FLANGES WITH 1/4-20 STUD MOUNTING

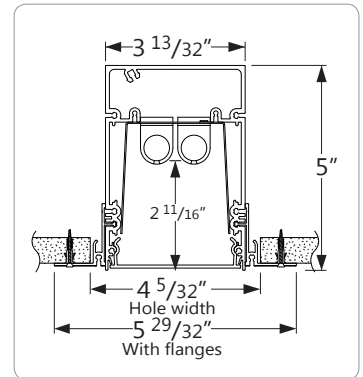

DS SPACKLE FLANGES

● **OTHER MOUNTING OPTIONS**

BEAM 3 is also available with pendant, surface, wall, asymmetric, recessed wall and wall wash mounted options.

i Specification sheets and Installation sheets for all mounting for BEAM luminaires are available for download at www.axislighting.com

● **INTEGRATED CONTROL OPTIONS**

BEAM 3 luminaires allow the use of integrated controls such as daylight sensors (DS), occupancy sensors (OS) and combination daylight/occupancy sensors (DOS). These options can be seamlessly integrated into our luminaires. The control system could be used to optimize the lighting of the space by reducing energy consumption through daylight harvesting and occupancy, thereby improving the overall interior environment and allowing for LEED credits.

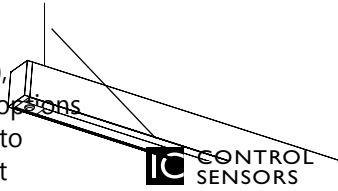

- Consult factory for other options.

SENSORS	BRAND	Model	TYPE	CODE	COMPATIBLE DIMMING BALLAST
Daylight Sensor (DS)	Lutron	EC-DIR-WH	Daylight	LD	EcoSystem
	Wattstopper	FD-301	Daylight	WD	0-10V
	Philips	Luxsense	Daylight	PL	0-10V
Occupancy Sensor (OS)	Wattstopper	FS-205	PIR Occupancy	WP1	Programmed Rapid Start
		FS-355	PIR Occupancy	WP2	Programmed Rapid Start
		FM-105	High Frequency Occupancy	WH	Programmed Rapid Start
Daylight & Occupancy Sensors (DOS)	Philips	Actilume	Daylight & PIR Occupancy	PA	DALI or 0-10V

● **PHOTOMETRIC DATA**

I T5

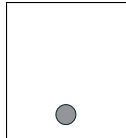

PHOTOMETRIC CURVE

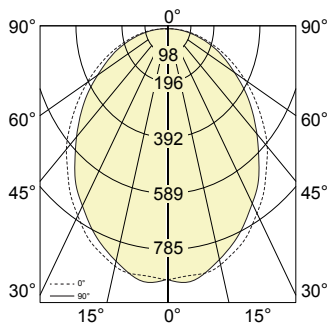

Test Lamp: 1xT5
 IES FILE: BMR-F-FL-4-T5-1

Efficiency: 68.5 %

CANDELA DISTRIBUTION

Vertical Angle	Horizontal Angles					Zonal Lumens
	0	22.5	45	67.5	90	
0	873	873	873	873	873	
5	862	879	850	872	883	47
15	821	816	807	808	799	196
25	721	713	705	693	683	306
35	596	590	569	559	550	356
45	468	457	440	423	417	350
55	338	329	315	303	295	300
65	223	216	207	199	197	226
75	122	119	114	110	108	143
85	42	41	36	33	32	61
90	6	4	3	2	2	

LUMINANCE DATA (CD/M²)

Vertical Angle	Horizontal Angles		
	0	45	90
45	4690	2745	2312
55	4038	2050	1663
65	3420	1449	1168
75	2750	899	698
85	1851	331	235

COEFFICIENTS OF UTILIZATION (%)

Ceiling	80			70			50				
	70	50	30	10	70	50	30	10	50	30	10
Wall	70	50	30	10	70	50	30	10	50	30	10
0	82	82	82	82	80	80	80	80	76	76	76
1	75	72	69	66	73	70	68	65	67	65	63
2	68	63	59	55	67	62	58	54	59	56	53
3	63	56	50	46	61	55	50	46	53	48	45
4	58	50	44	40	56	49	43	39	47	42	39
5	53	45	39	34	52	44	38	34	43	38	34
6	49	41	35	30	48	40	34	30	39	34	30
7	46	37	31	27	45	36	31	27	35	30	27
8	43	34	28	24	42	33	28	24	33	28	24
9	40	31	26	22	39	31	26	22	30	25	22
10	38	29	24	20	37	29	24	20	28	23	20

Based on floor reflectance of 20

i All IES files for other lamping are available for download at: www.axislighting.com

● **PHOTOMETRIC DATA**

2 T5

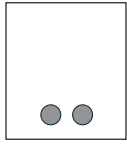

PHOTOMETRIC CURVE

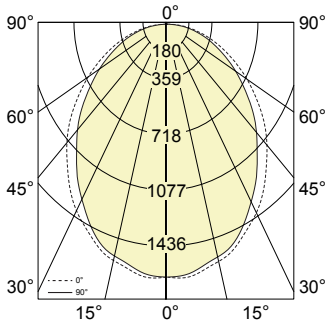

Test Lamp: 2x F28T5
 IES FILE: BMR-F-FL-4-T5-2
Efficiency: 62.7%

CANDELA DISTRIBUTION

Vertical Angle	Horizontal Angles					Zonal Lumens
	0	22.5	45	67.5	90	
0	1611	1611	1611	1611	1611	
5	1616	1614	1604	1611	1595	86
15	1517	1499	1506	1483	1488	362
25	1334	1320	1286	1263	1257	563
35	1099	1090	1050	1004	997	652
45	868	839	810	777	762	641
55	624	603	571	543	536	547
65	408	400	377	360	347	413
75	225	221	209	199	193	260
85	78	73	65	60	56	110
90	10	8	5	3	3	

COEFFICIENTS OF UTILIZATION (%)

Ceiling	80			70			50				
	70	50	30	10	70	50	30	10	50	30	10
Wall	70	50	30	10	70	50	30	10	50	30	10
0	75	75	75	75	73	73	73	73	70	70	70
1	69	66	63	61	67	64	62	60	62	60	58
2	63	58	54	50	61	57	53	50	54	51	48
3	58	51	46	42	56	50	46	42	48	44	41
4	53	46	40	36	52	45	40	36	43	39	36
5	49	41	36	32	48	40	35	31	39	35	31
6	45	37	32	28	44	37	32	28	36	31	28
7	42	34	29	25	41	33	28	25	32	28	25
8	39	31	26	22	38	31	26	22	30	25	22
9	37	29	24	20	36	28	24	20	28	23	20
10	35	27	22	19	34	26	22	18	26	21	18

Based on floor reflectance of 20

LUMINANCE DATA (CD/M²)

Vertical Angle	Horizontal Angles		
	0	45	90
45	8698	5056	4224
55	7460	3718	3027
65	6260	2645	2059
75	5062	1648	1247
85	3466	600	414

1 T5

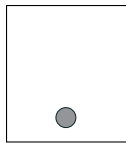

PHOTOMETRIC CURVE

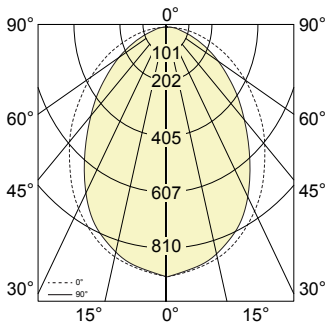

Test Lamp: 1x F14T5
 IES FILE: BMR-F-RG-4-T5-1
Efficiency: 64.6%

CANDELA DISTRIBUTION

Vertical Angle	Horizontal Angles					Zonal Lumens
	0	22.5	45	67.5	90	
0	911	911	911	911	911	
5	894	904	888	892	889	48
15	844	837	842	832	820	201
25	746	738	717	699	690	314
35	617	612	570	533	514	357
45	485	470	418	376	364	338
55	352	331	279	244	235	276
65	233	208	167	140	131	195
75	126	103	73	57	53	107
85	33	21	19	18	17	37
90	2	2	2	2	2	

COEFFICIENTS OF UTILIZATION (%)

Ceiling	80			70			50				
	70	50	30	10	70	50	30	10	50	30	10
Wall	70	50	30	10	70	50	30	10	50	30	10
0	77	77	77	77	75	75	75	75	72	72	72
1	71	68	66	64	69	67	65	63	64	62	61
2	65	61	57	53	64	59	56	53	57	54	51
3	60	54	49	45	59	53	48	45	51	47	44
4	55	48	43	39	54	47	43	39	46	42	38
5	51	44	38	34	50	43	38	34	42	37	34
6	48	40	34	30	46	39	34	30	38	33	30
7	44	36	31	27	43	36	31	27	35	30	27
8	41	33	28	24	41	33	28	24	32	27	24
9	39	31	26	22	38	30	25	22	30	25	22
10	37	28	24	20	36	28	23	20	27	23	20

Based on floor reflectance of 20

LUMINANCE DATA (CD/M²)

Vertical Angle	Horizontal Angles		
	0	45	90
45	4791	2423	1850
55	4124	1658	1198
65	3478	1053	692
75	2704	509	297
85	1329	148	109

i All IES files for other lamping are available for download at: www.axislighting.com

● **PHOTOMETRIC DATA**

1 T5HO

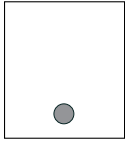

PHOTOMETRIC CURVE

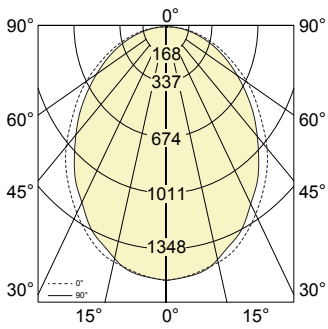

Test Lamp: 1xF54T5HO
 IES FILE: BMR-F-FL-4-T5HO-1

Efficiency: 68.5%

CANDELA DISTRIBUTION

Vertical Angle	Horizontal Angles					Zonal Lumens
	0	22.5	45	67.5	90	
0	1516	1516	1516	1516	1516	
5	1494	1503	1510	1503	1498	81
15	1416	1404	1395	1384	1373	336
25	1244	1225	1209	1192	1175	526
35	1040	1011	990	955	952	614
45	798	790	764	733	726	603
55	587	565	545	522	513	518
65	383	373	355	341	339	390
75	214	204	199	190	186	247
85	74	70	61	56	57	105
90	9	8	5	3	3	

COEFFICIENTS OF UTILIZATION (%)

Ceiling	80			70			50				
	70	50	30	10	70	50	30	10	50	30	10
Wall	70	50	30	10	70	50	30	10	50	30	10
0	82	82	82	82	80	80	80	80	76	76	76
1	75	72	69	66	73	70	68	65	67	65	63
2	69	63	59	55	67	62	58	54	59	56	53
3	63	56	50	46	61	55	50	46	53	48	45
4	58	50	44	40	56	49	43	39	47	42	39
5	53	45	39	34	52	44	38	34	43	38	34
6	49	41	35	30	48	40	34	30	39	34	30
7	46	37	31	27	45	36	31	27	35	30	27
8	43	34	28	24	42	33	28	24	33	28	24
9	40	31	26	22	39	31	26	22	30	25	22
10	38	29	24	20	37	29	24	20	28	23	20

Based on floor reflectance of 20

LUMINANCE DATA (CD/M²)

Vertical Angle	Horizontal Angles		
	0	45	90
45	7996	4773	4021
55	7008	3547	2895
65	5882	2495	2013
75	4810	1568	1199
85	3262	571	417

2 T5HO

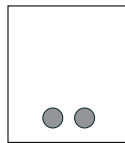

PHOTOMETRIC CURVE

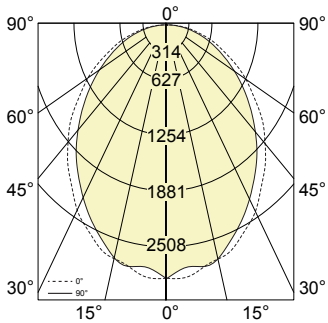

Test Lamp: 2xF54T5HO
 IES FILE: BMR-F-FL-4-T5HO-2

Efficiency: 62.7%

CANDELA DISTRIBUTION

Vertical Angle	Horizontal Angles					Zonal Lumens
	0	22.5	45	67.5	90	
0	2822	2822	2822	2822	2822	
5	2811	2813	2746	2723	2705	149
15	2632	2611	2570	2578	2560	625
25	2312	2270	2242	2176	2159	970
35	1904	1880	1812	1755	1744	1127
45	1498	1456	1390	1324	1312	1104
55	1079	1035	993	944	926	943
65	694	683	651	612	599	710
75	384	377	361	337	330	446
85	133	125	113	104	98	189
90	18	13	8	6	5	

COEFFICIENTS OF UTILIZATION (%)

Ceiling	80			70			50				
	70	50	30	10	70	50	30	10	50	30	10
Wall	70	50	30	10	70	50	30	10	50	30	10
0	75	75	75	75	73	73	73	73	70	70	70
1	69	66	63	61	67	64	62	60	62	60	58
2	63	58	54	50	61	57	53	50	54	51	49
3	58	51	46	42	56	50	46	42	48	44	41
4	53	46	40	36	52	45	40	36	43	39	36
5	49	41	36	32	48	40	35	32	39	35	31
6	45	37	32	28	44	37	32	28	36	31	28
7	42	34	29	25	41	33	28	25	33	28	25
8	39	31	26	22	38	31	26	22	30	25	22
9	37	29	24	20	36	28	24	20	28	23	20
10	35	27	22	19	34	26	22	19	26	21	18

Based on floor reflectance of 20

LUMINANCE DATA (CD/M²)

Vertical Angle	Horizontal Angles		
	0	45	90
45	15018	8678	7268
55	12889	6465	5224
65	10666	4572	3556
75	8627	2841	2135
85	5900	1054	720

i All IES files for other lamping are available for download at: www.axislighting.com

● PHOTOMETRIC DATA

I T5HO

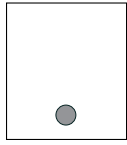

PHOTOMETRIC CURVE

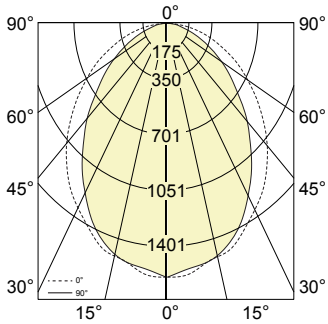

Test Lamp: IxF54T5HO
 IES FILE: BMR-F-RG-4-T5HO-1

Efficiency: 64.6%

CANDELA DISTRIBUTION

Vertical Angle	Horizontal Angles					Zonal Lumens
	0	22.5	45	67.5	90	
0	1577	1577	1577	1577	1577	
5	1563	1549	1545	1554	1529	83
15	1463	1450	1447	1444	1430	348
25	1280	1273	1243	1200	1183	539
35	1076	1053	985	917	893	616
45	836	805	723	651	618	583
55	603	566	484	421	405	477
65	395	360	288	241	225	335
75	217	179	124	101	93	185
85	58	36	32	29	30	64
90	3	3	3	3	3	

COEFFICIENTS OF UTILIZATION (%)

Ceiling	80			70			50				
	70	50	30	10	70	50	30	10	50	30	10
Wall	70	50	30	10	70	50	30	10	50	30	10
0	77	77	77	77	75	75	75	75	72	72	72
1	71	68	66	64	70	67	65	63	64	62	61
2	65	61	57	53	64	59	56	53	57	54	51
3	60	54	49	45	59	53	48	45	51	47	44
4	55	48	43	39	54	47	43	39	46	42	38
5	51	44	38	34	50	43	38	34	42	37	34
6	48	40	34	30	46	39	34	30	38	33	30
7	44	36	31	27	43	36	31	27	35	30	27
8	42	33	28	24	41	33	28	24	32	27	24
9	39	31	26	22	38	30	25	22	30	25	22
10	37	28	24	20	36	28	23	20	27	23	20

Based on floor reflectance of 20

LUMINANCE DATA (CD/M²)

Vertical Angle	Horizontal Angles		
	0	45	90
45	8262	4190	3145
55	7062	2882	2065
65	5906	1817	1190
75	4668	859	524
85	2342	255	188

I T8

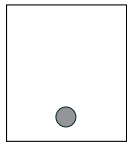

PHOTOMETRIC CURVE

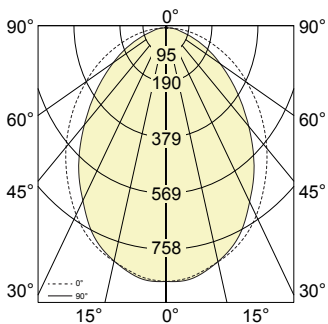

Test Lamp: IxF32T8
 IES FILE: BMR-F-RG-4-T8-1

Efficiency: 61.8%

CANDELA DISTRIBUTION

Vertical Angle	Horizontal Angles					Zonal Lumens
	0	22.5	45	67.5	90	
0	853	853	853	853	853	
5	843	837	834	838	850	45
15	789	788	786	785	782	189
25	703	699	689	662	653	297
35	582	580	549	512	504	340
45	457	449	404	366	352	324
55	333	317	272	238	225	267
65	221	201	160	134	127	188
75	120	98	68	53	49	101
85	32	20	17	17	16	35
90	2	2	2	2	2	

COEFFICIENTS OF UTILIZATION (%)

Ceiling	80			70			50				
	70	50	30	10	70	50	30	10	50	30	10
Wall	70	50	30	10	70	50	30	10	50	30	10
0	74	74	74	74	72	72	72	72	69	69	69
1	68	65	63	61	66	64	62	60	61	60	58
2	62	58	54	51	61	57	53	50	54	52	49
3	57	51	47	43	56	50	46	43	49	45	42
4	53	46	41	37	52	45	41	37	44	40	36
5	49	42	36	33	48	41	36	32	40	35	32
6	45	38	32	29	44	37	32	29	36	32	28
7	42	34	29	26	41	34	29	26	33	29	25
8	40	32	27	23	39	31	26	23	30	26	23
9	37	29	24	21	36	29	24	21	28	24	21
10	35	27	22	19	34	27	22	19	26	22	19

Based on floor reflectance of 20

LUMINANCE DATA (CD/M²)

Vertical Angle	Horizontal Angles		
	0	45	90
45	4403	2279	1742
55	3805	1580	1119
65	3225	987	653
75	2534	463	270
85	1299	134	100

i All IES files for other lamping are available for download at: www.axislighting.com

● PHOTOMETRIC DATA

I T8

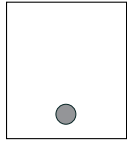

PHOTOMETRIC CURVE

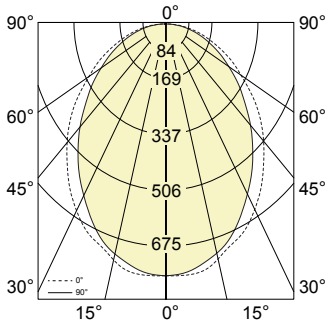

Test Lamp: IxF32T8

IES FILE: BMR-F-FL-4-T8-1

Efficiency: 56.9%

CANDELA DISTRIBUTION

Vertical Angle	Horizontal Angles					Zonal Lumens
	0	22.5	45	67.5	90	
0	752	752	752	752	752	
5	753	759	743	748	744	40
15	698	701	700	689	684	168
25	621	612	593	582	571	260
35	509	501	477	459	452	298
45	399	384	358	343	334	289
55	279	272	256	240	235	245
65	183	178	165	157	153	183
75	102	98	92	88	85	115
85	34	32	30	27	25	49
90	5	3	2	2	2	

LUMINANCE DATA (CD/M²)

Vertical Angle	Horizontal Angles		
	0	45	90
45	3862	2026	1656
55	3210	1487	1168
65	2690	1014	787
75	2164	626	469
85	1385	231	155

COEFFICIENTS OF UTILIZATION (%)

Ceiling	80			70			50				
	70	50	30	10	70	50	30	10	50	30	10
Wall	70	50	30	10	70	50	30	10	50	30	10
0	68	68	68	68	66	66	66	66	63	63	63
1	62	60	57	55	61	58	56	54	56	54	53
2	57	53	49	46	56	51	48	45	49	47	44
3	52	47	42	39	51	46	42	38	44	41	38
4	48	42	37	33	47	41	36	33	39	36	33
5	45	37	33	29	43	37	32	29	36	32	28
6	41	34	29	26	40	33	29	25	32	28	25
7	38	31	26	23	37	31	26	23	30	26	23
8	36	28	24	21	35	28	24	20	27	23	20
9	34	26	22	19	33	26	22	19	25	21	19
10	32	24	20	17	31	24	20	17	23	20	17

Based on floor reflectance of 20

i All IES files for other lamping are available for download at: www.axislighting.com