

● **PROJECT INFORMATION**

Project:

Type:

Notes:

● **DIMENSIONS**

SECTION VIEWS

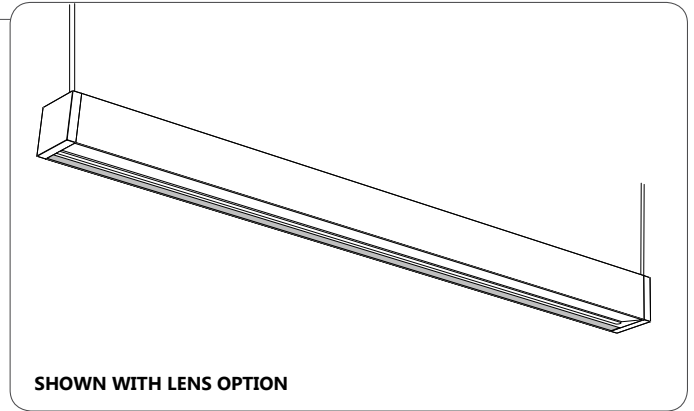
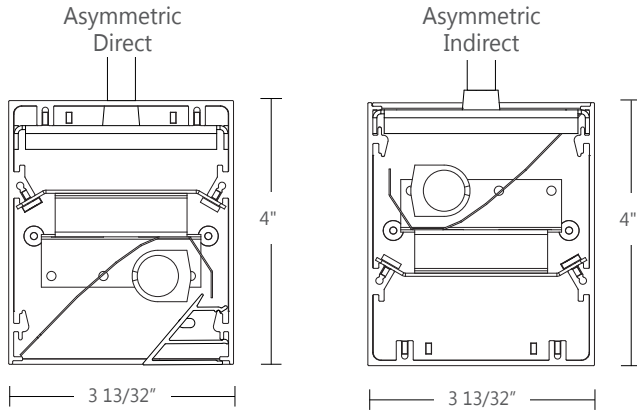

● **ORDERING CODE**

1	2	3	4	5	6	7	8	9	10	11	12	13	14	15	16
---	---	---	---	---	---	---	---	---	----	----	----	----	----	----	----

● **PRODUCT SPECIFICATIONS**

1	PRODUCT ID	2	OPTICS	3	LENGTH (FT)	4	SPECIFY LENGTH	5	LAMP	6	LAMP CONFIGURATION
BMD	pendant direct	A	asymmetric	2	2'	NL	nominal (3' & 4' lamps)	T5	T5	1	1 lamp
BMI	pendant indirect	AF	asymmetric frosted ⁽¹⁾	3	3'	NL4	nominal (4' lamps only)	T5HO	T5HO		
				4	4'	EX	exact (3' & 4' lamps)				
				5	5'	EX4	exact (4' lamps only)				
				6	6'						
				8	8'						
				12	12'						
				S#	System Run						
(1) For direct light distribution only											

7	MR	8	FINISH	9	VOLTAGE	10	BALLAST	11	CIRCUITS	12	MOUNTING/SUSPENSION
M16#	MR 16 halogen	AP	aluminum paint	120	120 V	D	dimming	1	1 regular	SA#	drywall+stem length >48" (18" std.)
M16LED#	MR 16 LED	W	white	277	277 V	E	instant start ⁽³⁾	2A/B	2 alternating		
		BLK	black	347	347 V ⁽²⁾	ERS	program start	+E(#)	emergency section		
		C	custom	UNV	universal	BI	bi-level dimming	+NL(#)	night light section		
								+GTD(#)	generator transfer device		
								+M	MR		
Add 9" per lamp Requires 120V or 277V					(2) Please consult factory	(3) Available with T8 lamp only					

13	BATTERY	14	OTHER	15	IC CONTROLS	16	CUSTOM
B#	battery pack 4' sections	F	fuse	DS#	daylight sensor	C	custom
				OS#	occupancy sensor		
				DOS#	daylight & occupancy sensor		
					See integrated controls guide for further details	Please specify	

● **CONSTRUCTION**

Housing	Extruded Aluminum (0.075" nominal) up to 70% Recycled Content
End Cap	Sheet Steel (18 ga)
Interior Brackets	Die Formed Sheet Steel (18 gauge)
Reflectors	White Powder Coated Sheet Steel (22 ga)
Blank	Extruded Aluminum (0.075" nominal)
Lenses	Extruded Acrylic (0.070" nominal) Frosted: 85% trans.
Suspension	Ø 1/2" Stem

● **WEIGHT**

4 ft	12.3 lbs / 5.0 kg
8 ft	24.6 lbs / 10.1 kg
12 ft	36.9 lbs / 15.1 kg

● **SYSTEM (S#)**

BEAM 3 linear systems, with the use of a strong profile, allow for a nearly hair thin connection system of continuous runs. Lengths of 4', 8', 12' as well as custom lengths are available. Runs of BEAM 3 that are greater than 12' in length are designated as systems (S#). This means that the run is comprised of a combination of 4', 8' and/or 12' sections to be assembled on site using our joining system. For more information on systems and joining, please refer to the BEAM installation sheets available for download at www.axislighting.com.

● **ELECTRICAL**

Ballast	Electronic IS, Electronic Rapid Start, Dimming (0-10V, Line, EcoSystem, DALI), BI-level dimming With preinstalled ballast disconnect as per NEC & CEC
Emergency	Emergency battery pack or emergency circuit
Voltage	120V, 277V, 347V, UNV

i Incorporating these components may have limitations or effect the length of the luminaire, please contact factory for more details.

● **APPROVALS**

Certified to UL and CUL standards 
 Meets NYC requirements
 Suitable for damp locations.

● **FINISH**

Aluminium paint, Powder Coated and custom finishes are also available.

● **JOINERS**

In order to allow very long runs of BEAM 3 luminaires, Axis has developed an effective joining system. Special care has been taken to maximize the performance of the joiner for each BEAM option.

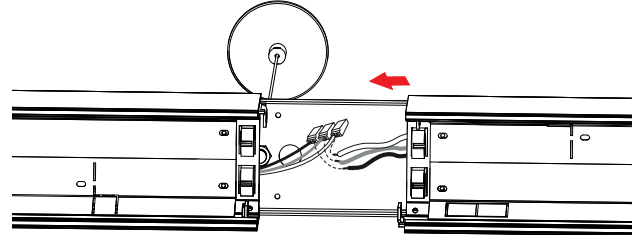

NOTE: Hang each system segment individually. Do not assemble system prior to hanging.

● **MR16**

Blank	Extruded Aluminum (0.075" nominal)
MR16 Halogens	2.0" diameter (35W / 50W)
MR16 LED	2.0" diameter
Quantity	For every 4' fluorescent lamp section, there may be up to a maximum of 4 x MR16 lamps.

Spacing

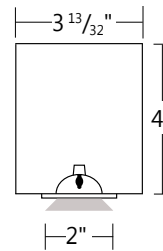

Each MR16 is placed centered on a blank section 9" in length.

For a series of MR16's within a given section length, they will be spaced evenly on a longer blank section. The directed light of MR16 Halogen lamps are fixed downward. Custom spacing may be available on special request. *Please consult factory

Between fluorescent lamps sections

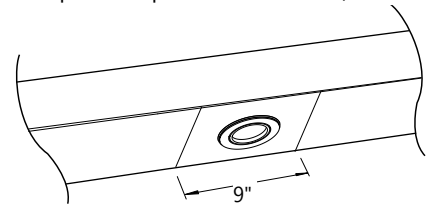

At luminaire ends

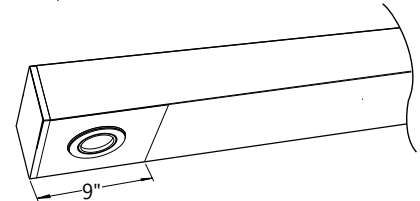

Several in a long blank section

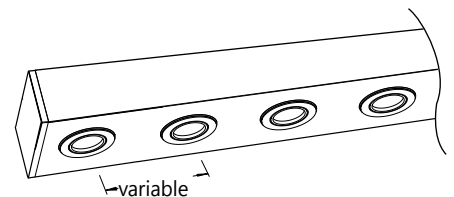

● OPTICS

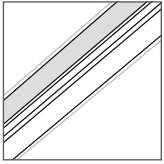

AF asymmetric frosted

ASYMMETRIC FROSTED LENS
 (acrylic snap-in lens)
 frosted: 85% trans.

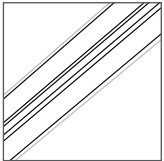

A asymmetric

ASYMMETRIC NO LENS
 (asymmetric reflector)

● ASYMMETRIC

Inner Asymmetric Reflector

Die Formed Specular Aluminum (22 gauge)

Outer Asymmetric Reflector

Extruded Aluminum (0.075" nominal)

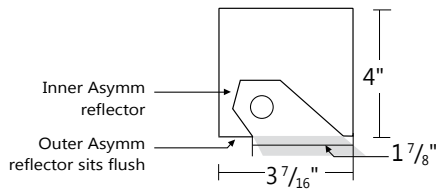

SA STEM MOUNT IN DRYWALL CEILING

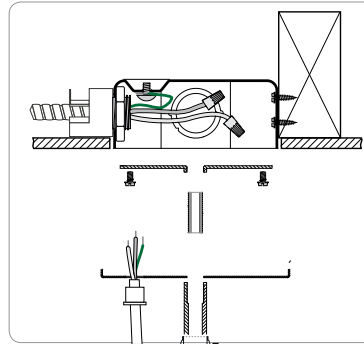

Power feed

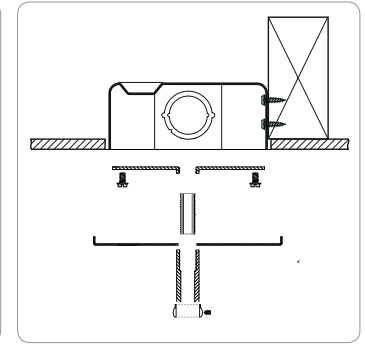

Non power feed

● MOUNTING SPACING

T5/T5HO LAMP	4'	(46 5/16" C.C.)
	8'	(92 5/8" C.C.)
	12'	(138 15/16" C.C.)

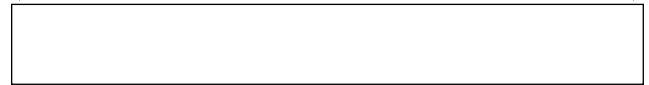

T8 LAMP	4'	(48" C.C.)
	8'	(96" C.C.)
	12'	(144" C.C.)



● OTHER MOUNTING OPTIONS

BEAM 3 is also available with recessed, surface, wall, recessed wall, asymmetric and wall wash mounted options.

i Specification sheets and Installation sheets for all mounting for BEAM luminaires are available for download at www.axislighting.com

● INTEGRATED CONTROL OPTIONS

BEAM 3 luminaires allow the use of integrated controls such as daylight sensors (DS), occupancy sensors (OS) and combination daylight/occupancy sensors (DOS). These options can be seamlessly integrated into our luminaires. The control system could be used to optimize the lighting of the space by reducing energy consumption through daylight harvesting and occupancy, thereby improving the overall interior environment and allowing for LEED credits.

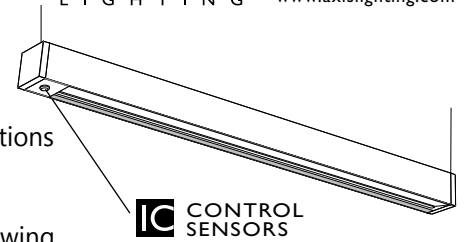

- Consult factory for other options.

SENSORS	BRAND	Model	TYPE	CODE	COMPATIBLE DIMMING BALLAST
Daylight Sensor (DS)	Lutron	EC-DIR-WH	Daylight	LD	EcoSystem
	Wattstopper	FD-301	Daylight	WD	0-10V
	Philips	Luxsense	Daylight	PL	0-10V
Occupancy Sensor (OS)	Wattstopper	FS-205	PIR Occupancy	WP1	Programmed Rapid Start
		FS-355	PIR Occupancy	WP2	Programmed Rapid Start
		FM-105	High Frequency Occupancy	WH	Programmed Rapid Start
Daylight & Occupancy Sensors (DOS)	Philips	Actilume	Daylight & PIR Occupancy	PA	DALI or 0-10V

● PHOTOMETRIC DATA

I T5

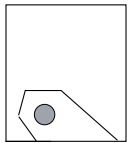

PHOTOMETRIC CURVE

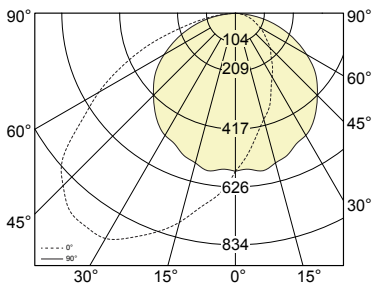

Test Lamp: IxF28T5
 IES FILE: BMD-A-4-T5-1

Efficiency: 70.3 %

CANDELA DISTRIBUTION

Vertical Angle	Horizontal Angles								Zonal Lumens
	0	23	45	68	90	135	157	180	
0	569	569	569	569	569	569	569	569	
5	510	498	506	535	564	621	650	652	31
15	395	397	432	482	558	705	755	780	135
25	304	314	352	416	519	783	866	892	238
35	233	243	281	348	485	827	916	939	324
45	178	187	213	275	418	812	878	878	376
55	126	133	155	201	345	720	703	678	375
65	80	88	99	129	247	490	462	450	304
75	46	47	52	63	143	242	216	205	188
85	15	16	16	16	36	54	52	49	65
90	1	1	1	2	2	5	4	4	
95	0	0	0	0	0	0	0	0	2
105	0	0	0	0	0	0	0	0	0
115	0	0	0	0	0	0	0	0	0
125	0	0	0	0	0	0	0	0	0
135	0	0	0	0	0	1	0	0	0
145	0	0	0	0	0	1	1	1	0
155	0	0	0	0	0	0	1	1	0
165	0	0	0	0	0	0	0	0	0
175	0	0	0	0	0	0	0	0	0
180	0	0	0	0	0	0	0	0	

COEFFICIENTS OF UTILIZATION (%)

Ceiling	80			70			50				
	70	50	30	10	70	50	30	10	50	30	10
Wall	70	50	30	10	70	50	30	10	50	30	10
0	84	84	84	84	82	82	82	82	78	78	78
1	76	73	69	67	74	71	68	66	68	66	63
2	69	63	58	54	67	61	57	53	59	55	52
3	62	55	49	44	61	54	48	44	51	47	43
4	57	48	42	37	55	47	41	36	45	40	36
5	52	43	36	31	51	42	36	31	40	35	31
6	48	38	32	27	47	38	31	27	36	31	27
7	44	34	28	24	43	34	28	24	33	27	23
8	41	31	25	21	40	31	25	21	30	24	21
9	38	29	23	19	37	28	22	19	27	22	18
10	36	26	21	17	35	26	20	17	25	20	17

Based on floor reflectance of 20

LUMINANCE DATA (CD/M²)

Vertical Angle	Horizontal Angles				
	0	23	90	135	180
45	984	1060	4189	5069	4866
55	708	770	4126	4687	3829
65	477	539	3792	3441	2673
75	296	317	3210	1908	1326
85	112	120	1594	498	358

i All IES files for other lamping are available for download at: www.axislighting.com

● PHOTOMETRIC DATA

I T5HO

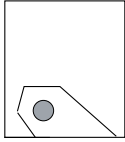

PHOTOMETRIC CURVE

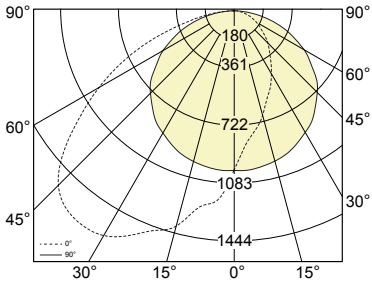

Test Lamp: 1xF54T5HO
 IES FILE: BMD-A-4-T5HO-1

Efficiency: 70.3 %

CANDELA DISTRIBUTION

Vertical Angle	Horizontal Angles							Zonal Lumens
	0	23	45	68	90	135	157	
0	987	987	987	987	987	987	987	
5	833	884	895	915	989	1094	1093	31
15	678	697	742	807	965	1229	1305	135
25	530	546	611	729	912	1357	1490	238
35	403	420	490	604	838	1434	1575	324
45	303	322	369	470	728	1398	1517	376
55	211	231	268	345	585	1231	1212	375
65	143	148	172	217	423	849	790	304
75	80	81	88	109	244	426	374	188
85	27	27	27	28	63	96	88	65
90	1	1	2	3	4	9	7	
95	0	0	0	0	0	0	0	2
105	0	0	0	0	0	0	0	0
115	0	0	0	0	0	0	0	0
125	0	0	0	0	0	0	0	0
135	0	0	0	0	0	1	0	0
145	0	0	0	0	0	1	1	0
155	0	0	0	0	0	1	1	0
165	0	0	0	0	0	0	0	0
175	0	0	0	0	0	0	0	0
180	0	0	0	0	0	0	0	

COEFFICIENTS OF UTILIZATION (%)

Ceiling	80			70			50				
	70	50	30	10	70	50	30	10	50	30	10
Wall	70	50	30	10	70	50	30	10	50	30	10
0	84	84	84	84	82	82	82	82	78	78	78
1	76	73	70	67	74	71	68	66	68	66	64
2	69	63	58	54	67	62	57	53	59	55	52
3	63	55	49	44	61	54	48	44	52	47	43
4	57	48	42	37	55	47	41	37	45	40	36
5	52	43	36	31	51	42	36	31	40	35	31
6	48	38	32	27	47	38	31	27	36	31	27
7	44	35	28	24	43	34	28	24	33	27	23
8	41	31	25	21	40	31	25	21	30	25	21
9	38	29	23	19	37	28	23	19	27	22	19
10	36	26	21	17	35	26	20	17	25	20	17

Based on floor reflectance of 20

LUMINANCE DATA (CD/M²)

Vertical Angle	Horizontal Angles				
	0	23	90	135	180
45	1678	1822	7302	8729	8498
55	1192	1336	6991	8013	6623
65	850	901	6495	5958	4577
75	519	540	5483	3351	2267
85	201	210	2810	895	613

i All IES files for other lamping are available for download at: www.axislighting.com