

● PROJECT INFORMATION

Project:

Type:

Notes:

● DIMENSIONS

SECTION VIEWS

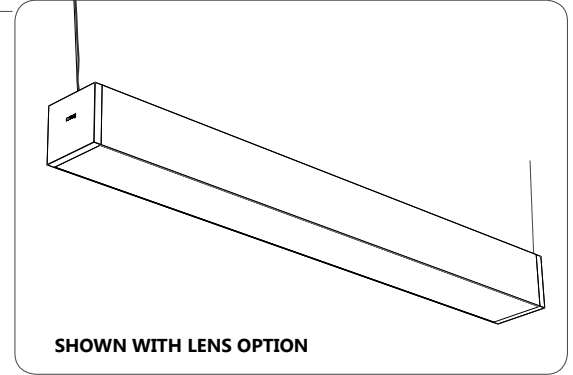
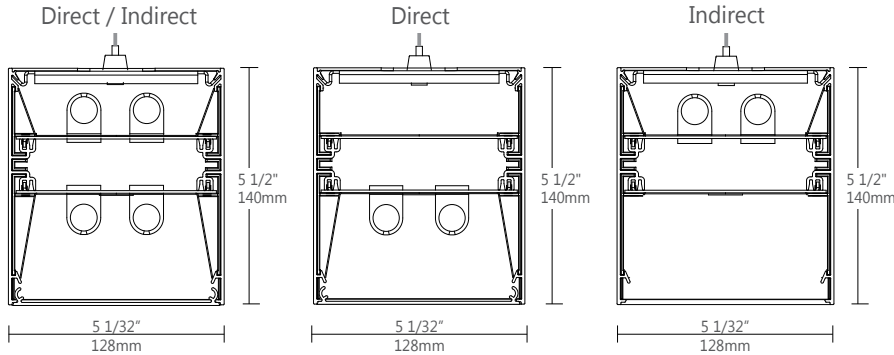

● ORDERING CODE

1	2	3	4	5	6	7	8	9	10	11	12	13	14	15	16	17	18
---	---	---	---	---	---	---	---	---	----	----	----	----	----	----	----	----	----

● PRODUCT SPECIFICATIONS

1	PRODUCT ID	2	OPTICS DIRECT	3	OPTICS INDIRECT	4	LENGTH (FT)	5	SPECIFY LENGTH	6	LAMP
B6	pendant direct/indirect	S	satin lens	NO	no lens	2	2'	NL	nominal (3' & 4' lamps)	T5	T5
B6D	pendant direct	F	frosted lens ⁽¹⁾			3	3'	NL4	nominal (4' lamps only)	T5HO	T5HO
B6I	pendant indirect	PL	semi spec. para. louvers			4	4'	EX	exact (3' & 4' lamps)	T8	T8
		B	blank			5	5'	EX4	exact (4' lamps only)		
						6	6'				
						8	8'				
						12	12'				
						S#	System Run				
(1) not recommended with staggered lampping											

7	DOWN LAMP	8	UP LAMP	9	MR	10	FINISH	11	VOLTAGE	12	BALLAST	13	CIRCUITS
0	0 lamp ⁽²⁾	0	0 lamp ⁽⁵⁾	M16#	MR 16 halogen	AP	aluminum paint	120	120V	D	dimming	1	1 regular
1	1 lamp	1	1 lamp	M16LED#	MR 16 LED	W	white	277	277V	E	instant start ⁽⁷⁾	2	2 regular
2	2 lamp	2	2 lamps			BLK	black	347	347V ⁽⁶⁾	ERS	program start	2A/B	2 alternating
3	3 lamp ⁽³⁾	3	3 lamps			C	custom	UNV	universal	BI	bi-level dimming	+E(#)	emergency section
+S	staggered ⁽⁴⁾	+S	staggered									+NL(#)	night light section
												+GTD(#)	generator transfer device
												+M	MR
(2) Available only with indirect. Configuration for staggered lampping must be the same for up and down.		(5) Available only with direct. Configuration for staggered lampping must be the same for up and down.		Add 9" per lamp Requires 120V or 277V				(6) Please consult factory		(7) Available with T8 lamp only			
(3) Not available with T8 lamp.		(4) Available with 1 lamp only											

14	MOUNTING/SUSPENSION	15	BATTERY	16	OTHER	17	IC CONTROLS (OPTIONAL)	18	CUSTOM (OPTIONAL)
CA#	drywall+cable length (36" std.)	B#	battery pack 4' sections	D	dust cover	DS#	daylight sensor	C	custom
CT9-#	TB/TG 9/16+cable length (36" std.)			F	fuse	OS#	occupancy sensor		
CT15-#	TB/TG15/16+cable length (36" std.)					DS+OS#	daylight+occupancy sensor		
CTS#	ST+cable length (36" std.)					DOS#	daylight&occupancy sensor		
SA#	drywall+stem length >48" (18" std.)								
See ceiling mounting guide for further details						See integrated controls guide for further details		Please specify	

FILE NAME: B6.SPEC May 17, 2016

● CONSTRUCTION

Housing	Extruded Aluminum (0.075" nominal) 70% Recycled Content
End Cap	Die Cast Zinc (0.060" nominal)
Interior Brackets	Die Formed Sheet Steel (18 gauge)
Reflectors	White Powder Coated Sheet Steel (22 ga)
Louvers	Die Formed Semi-Specular Aluminum (22 ga)
White Louver	Die Formed Aluminum Painted White (22 ga)
Lenses	Extruded Acrylic (0.070" nominal) Satin: 68% trans. Frosted: 85% trans.

Hanger	Die Formed Sheet Steel (16 gauge)
Suspension	Aircraft Cable or Ø 1/2" Stem
Cable Grips	Quick Connecting / Release

● WEIGHT

4 ft	16.3 lbs / 7.4 kg
8 ft	32.6 lbs / 14.8 kg
12 ft	48.9 lbs / 22.2 kg

● SYSTEM (S#)

BEAM 6 linear systems, with the use of a strong profile, allow for a nearly hair thin connection system of continuous runs. Lengths of 4', 8', 12' as well as custom lengths are available. Runs of BEAM 6 that are greater than 12' in length are designated as systems (S#). This means that the run is comprised of a combination of 4', 8' and/or 12' sections to be assembled on site using our joining system. For more information on systems and joining, please refer to the BEAM installation sheets available for download at www.axislighting.com.

● ELECTRICAL

Ballast Electronic IS, Electronic Rapid Start, Dimming (0-10V, Line, EcoSystem, DALI), BI-level dimming
With preinstalled ballast disconnect as per NEC & CEC

Emergency Emergency battery pack or emergency circuit

Voltage 120V, 277V, 347V, UNV

i Incorporating these components may have limitations or effect the length of the luminaire, please contact factory for more details.

● FINISH

Aluminium paint, Powder Coated and custom finishes are also available.

● APPROVALS

Certified to UL and CUL standards
 Meets NYC requirements
 Suitable for damp locations.

● JOINERS

In order to allow very long runs of BEAM 6 luminaires, Axis has developed an effective joining system. Special care has been taken to maximize the performance of the joiner for each BEAM option.

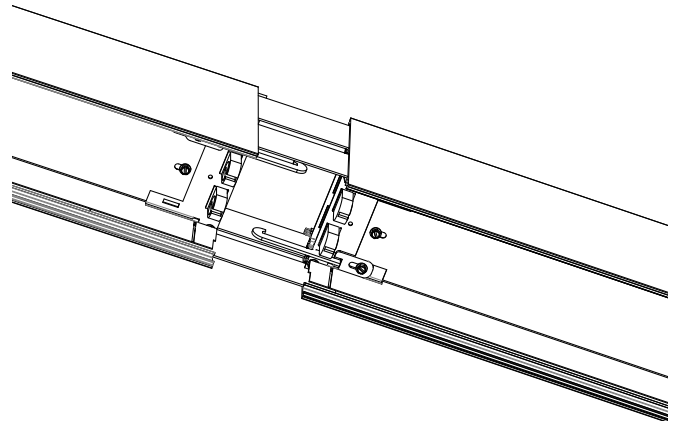

NOTE: Hang each system segment individually. Do not assemble system prior to hanging.

● STAGGERED LAMPING

When BEAM 6 is used in continuous runs longer than 4', staggered lamping can be used to eliminate the appearance of socket shadows at the ends of the lamps. BEAM 6 uses a staggered overlap of 4 different overlapping bracket lengths (3.5", 4", 4.5" and 5"), along with 3' and 4' lamps, allowing us to match almost any row length requirements with optimal results. For example 3 x 3' staggered T5 lamps can be used to completely illuminate the lens of an 8' nominal luminaire.

LAMP TYPE	T5	T5HO	T8
1 lamp	•	•	•

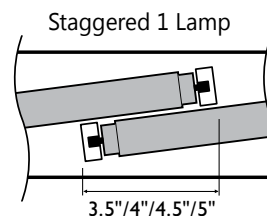

● **OPTICS**

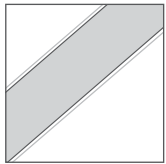

S satin lens

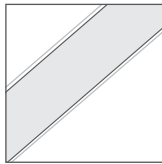

F frosted lens

SATIN & FROSTED LENS

(acrylic snap-in lens)
 satin: 68% trans.
 frosted: 85% trans.

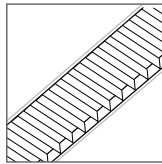

PL semi-specular parabolic louvers

LOUVERS

(semi-spec. parabolic louver)
 9/16" deep blades – 5/8" spacing
 72 blades per 4'

● **CORNERS**

Unlit Corners - BEAM6

features a multitude of layout patterns with the use of a number of corners, 90° corner, T or X junctions.

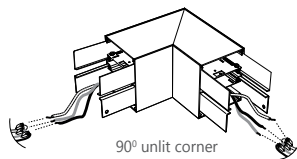

90° unlit corner

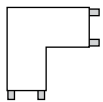

90° corner

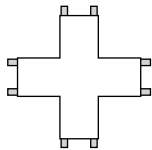

X junction

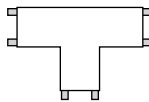

T junction

Lit Corners - In addition Axis offers Lit 90° Corners including Ceiling to Ceiling, Wall to Ceiling and Ceiling to Wall.

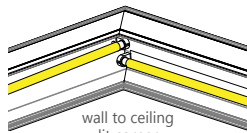

wall to ceiling lit corner

i For custom corner angles, please consult factory. Specifications sheets for all corners are available at: www.axislighting.com

● **MR16**

Blank MR16 Halogens Quantity

Extruded Aluminum (0.075" nominal)
 2.0" diameter (35W / 50W)

For every 4' fluorescent lamp section, there may be up to a maximum of 4 x MR16 lamps.

Spacing

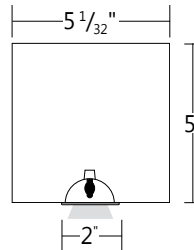

Each MR16 is placed centered on a blank section 9" in length.

For a series of MR16's within a given section length, they will be spaced evenly on a longer blank section. The directed light of MR16 Halogen lamps are fixed downward. Custom spacing may be available on special request.

Between fluorescent lamps sections

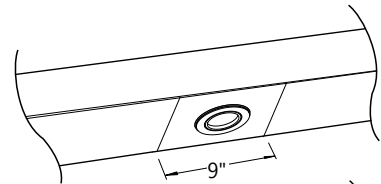

At luminaire ends

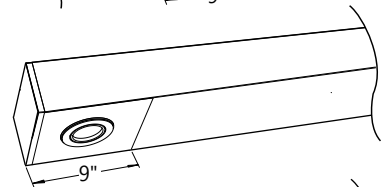

Several in a long blank section

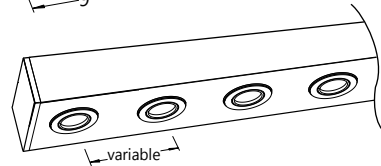

● MOUNTING SPACING END TO END

T5/T5HO LAMP	4'	(46 5/16" C.C.)
	8'	(92 5/8" C.C.)
	12'	(138 15/16" C.C.)

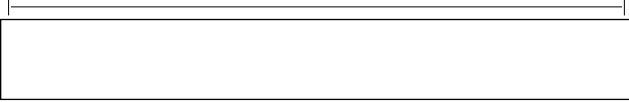

T8 LAMP	4'	(48" C.C.)
	8'	(96" C.C.)
	12'	(144" C.C.)



● MOUNTING SPACING STAGGERED

T5/T5HO 1 LAMP	T5/T5HO 2 LAMP
8' 3X3' (95 1/2" C.C.)	4' (50 5/16" C.C.)
8' 2X4' (88 5/8" C.C.)	8' (96 5/8" C.C.)
12' 3X4' (130 15/16" C.C.)	12' (142 15/16" C.C.)
12' 2X4'+2X3' (149 5/8" C.C.)	

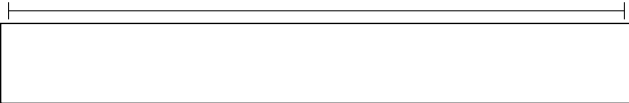

T8 1 LAMP	T8 2 LAMP
8' (92" C.C.)	4' (52" C.C.)
12' (136" C.C.)	8' (100" C.C.)
	12' (148" C.C.)

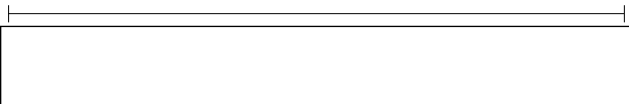

i Row configuration and mounting spacing file is available for download at: www.axislighting.com

● OTHER MOUNTING OPTIONS

BEAM 6 is also available with recessed, surface, wall, recessed wall, asymmetric and wall wash mounted options.

i Specification sheets and Installation sheets for all mounting for BEAM luminaires are available for download at www.axislighting.com

● MOUNTING OPTIONS

CT TILE CEILING - ON GRID

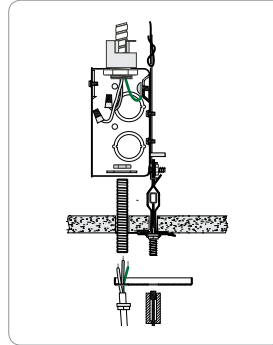

Power feed

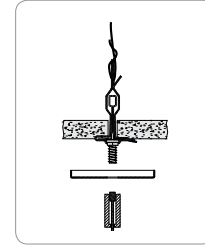

Non power feed

CA DRYWALL CEILING

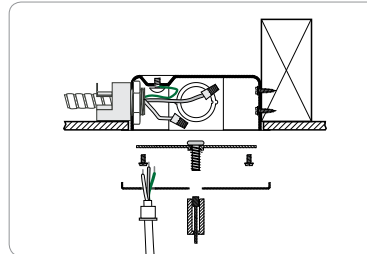

Power feed

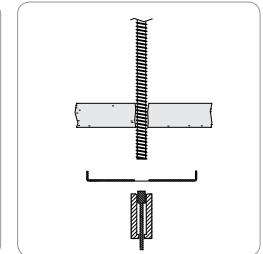

Non power feed

SA STEM MOUNT IN DRYWALL CEILING

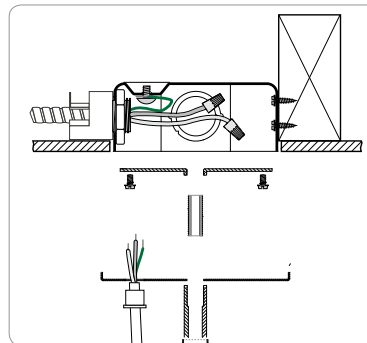

Power feed

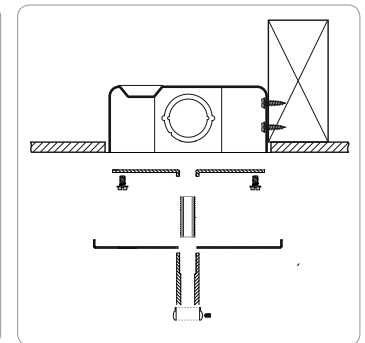

Non power feed

● **INTEGRATED CONTROL OPTIONS**

BEAM 6 luminaires allow the use of integrated controls such as daylight sensors (DS), occupancy sensors (OS), individual daylight sensors and occupancy sensors (DS+OS), and combination daylight/occupancy sensors (DOS). These options can be seamlessly integrated into our luminaires. The control system could be used to optimize the lighting of the space by reducing energy consumption through daylight harvesting and occupancy, thereby improving the overall interior environment and allowing for LEED credits.

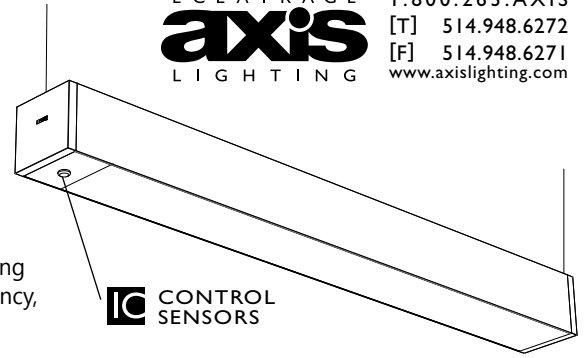

- Consult factory for other options.
- Refer to IC brochure for more information.

SENSORS	BRAND	Model	TYPE	CODE	COMPATIBLE DIMMING BALLAST
Daylight Sensor (DS)	Lutron	EC-DIR-WH	Daylight	LD	EcoSystem
	Wattstopper	FD-301	Daylight	WD	0-10V
	Philips	Luxsense	Daylight	PL	0-10V
Occupancy Sensor (OS)	Wattstopper	FS-205	PIR Occupancy	WP1	Programmed Rapid Start
		FS-355	PIR Occupancy	WP2	Programmed Rapid Start
		FM-105	High Frequency Occupancy	WH	Programmed Rapid Start
Daylight & Occupancy Sensors (DOS)	Philips	Actilume	Daylight & PIR Occupancy	PA	DALI or 0-10V

● **PHOTOMETRIC DATA**

2 T5

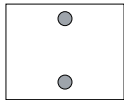

PHOTOMETRIC CURVE

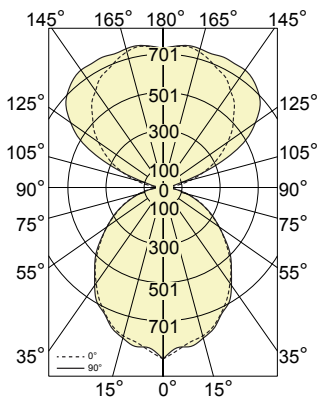

Test Lamp: 2xF28T5
 IES FILE: B6-F-FL-4-T5-1-1

Efficiency: 82.0%

CANDELA DISTRIBUTION

Vertical Angle	Horizontal Angles					Zonal Lumens
	0	22.5	45	67.5	90	
0	901	901	901	901	901	
5	860	860	877	876	845	47
15	808	816	815	819	819	196
25	726	726	733	736	731	316
35	614	615	619	621	628	381
45	490	490	495	494	501	387
55	362	363	364	364	360	343
65	244	241	242	241	243	263
75	138	138	134	130	132	167
85	49	47	45	40	40	71
90	7	6	5	4	3	
95	31	26	22	20	19	15
105	155	214	162	111	98	122
115	289	367	413	393	373	323
125	414	482	562	592	593	462
135	525	573	646	698	709	493
145	619	645	695	740	753	452
155	684	700	726	754	755	363
165	738	736	743	747	754	243
175	741	748	746	747	745	107
180	731	731	731	731	731	

COEFFICIENTS OF UTILIZATION (%)

Ceiling	80				70				50			
	70	50	30	10	70	50	30	10	50	30	10	
Wall												
0	87	87	87	87	80	80	80	80	66	66	66	
1	79	76	73	70	73	70	67	65	58	56	54	
2	72	66	61	57	66	61	57	53	51	48	45	
3	66	58	52	48	60	54	49	44	45	41	38	
4	60	52	45	40	55	48	42	38	40	36	32	
5	55	46	39	35	51	43	37	32	36	31	28	
6	51	41	35	30	47	38	32	28	32	28	24	
7	47	37	31	26	43	34	29	25	29	25	21	
8	44	34	27	23	40	31	26	22	27	22	19	
9	41	31	25	21	37	29	23	19	24	20	17	
10	38	28	22	18	35	26	21	17	23	18	15	

Based on floor reflectance of 20

LUMINANCE DATA (CD/M²)

Vertical Angle	Horizontal Angles		
	0	45	90
45	4041	2506	2255
55	3532	1904	1639
65	3028	1354	1157
75	2447	835	677
85	1606	323	234

i All IES files for other lamping are available for download at: www.axislighting.com

● PHOTOMETRIC DATA

3 T5

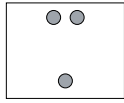

PHOTOMETRIC CURVE

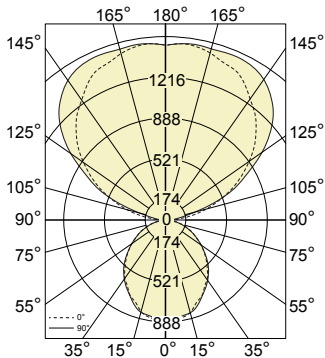

Test Lamp: 3xT5
 IES FILE: B6-F-FL-4-T5-1-2
Efficiency: 82.9%

CANDELA DISTRIBUTION

Vertical Angle	Horizontal Angles					Zonal Lumens
	0	22.5	45	67.5	90	
0	892	892	892	892	892	
5	857	848	840	851	844	46
15	762	769	776	782	790	197
25	664	680	683	683	680	314
35	551	553	564	558	568	382
45	424	429	429	430	428	389
55	294	303	301	299	299	342
65	187	191	186	184	181	263
75	94	92	88	85	85	167
85	49	48	45	41	41	72
90	7	6	5	4	3	
95	66	49	35	33	34	26
105	333	380	313	229	202	232
115	607	717	700	661	642	590
125	870	975	1053	1025	1004	846
135	1104	1176	1276	1321	1318	959
145	1280	1341	1407	1469	1492	910
155	1440	1449	1498	1540	1555	744
165	1509	1526	1534	1547	1551	500
175	1552	1534	1553	1556	1553	221
180	1534	1534	1534	1534	1534	

COEFFICIENTS OF UTILIZATION (%)

Ceiling	80				70				50			
Wall	70	50	30	10	70	50	30	10	50	30	10	
0	85	85	85	85	76	76	76	76	60	60	60	
1	78	74	71	68	69	67	64	62	53	51	49	
2	71	65	60	56	63	58	54	51	46	43	41	
3	64	57	51	46	58	51	46	42	41	37	34	
4	59	50	44	39	53	45	40	36	36	32	29	
5	54	45	38	33	48	40	35	31	32	28	25	
6	50	40	33	29	44	36	30	26	29	25	22	
7	46	36	30	25	41	33	27	23	26	22	19	
8	42	32	26	22	38	29	24	20	24	20	17	
9	39	30	24	19	35	27	22	18	22	18	15	
10	37	27	21	17	33	25	19	16	20	16	13	

Based on floor reflectance of 20

LUMINANCE DATA (CD/M²)

Vertical Angle	Horizontal Angles		
	0	45	90
45	4021	2503	2254
55	3520	1902	1645
65	3052	1362	1135
75	2491	841	677
85	1602	324	235

3 T5

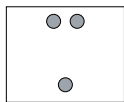

PHOTOMETRIC CURVE

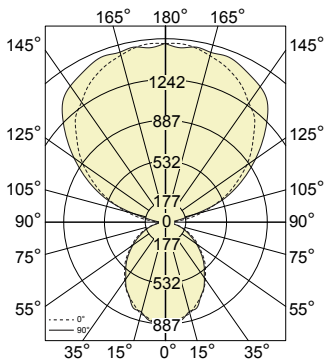

Test Lamp: 3xT5
 IES FILE: B6-F-FL-4S-T5-1S-2
Efficiency: 82.3%

CANDELA DISTRIBUTION

Vertical Angle	Horizontal Angles					Zonal Lumens
	0	22.5	45	67.5	90	
0	876	876	876	876	876	
5	896	879	866	871	888	47
15	834	824	825	834	819	199
25	735	744	746	727	733	320
35	616	612	612	614	600	380
45	491	490	482	471	473	379
55	356	356	348	339	338	329
65	239	235	229	223	218	250
75	133	132	128	123	122	159
85	47	44	40	38	39	68
90	7	6	4	4	3	
95	59	51	38	36	35	26
105	326	369	340	262	231	243
115	610	689	685	662	657	591
125	875	970	1013	987	971	830
135	1109	1186	1260	1274	1275	942
145	1294	1356	1417	1470	1473	911
155	1444	1461	1508	1537	1552	748
165	1535	1530	1549	1575	1567	507
175	1597	1572	1565	1565	1561	224
180	1593	1593	1593	1593	1593	

COEFFICIENTS OF UTILIZATION (%)

Ceiling	80				70				50			
Wall	70	50	30	10	70	50	30	10	50	30	10	
0	84	84	84	84	76	76	76	76	59	59	59	
1	77	73	70	68	69	66	63	61	52	50	49	
2	70	64	59	55	63	58	54	50	46	43	40	
3	64	56	51	46	57	51	46	42	40	37	34	
4	58	50	44	39	52	45	40	35	36	32	29	
5	54	44	38	33	48	40	35	30	32	28	25	
6	49	40	33	29	44	36	30	26	29	25	22	
7	45	36	29	25	41	32	27	23	26	22	19	
8	42	32	26	22	38	29	24	20	24	20	17	
9	39	29	23	19	35	27	21	18	22	18	15	
10	36	27	21	17	33	24	19	16	20	16	13	

Based on floor reflectance of 20

LUMINANCE DATA (CD/M²)

Vertical Angle	Horizontal Angles		
	0	45	90
45	4031	2380	2068
55	3445	1765	1488
65	2929	1238	996
75	2331	761	601
85	1488	279	213

i All IES files for other lamping are available for download at: www.axislighting.com

● PHOTOMETRIC DATA

2 T5HO

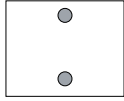

PHOTOMETRIC CURVE

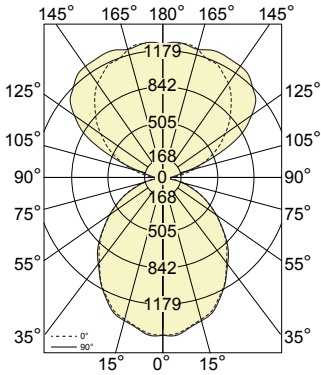

Test Lamp: 2x**F54T5HO**
 IES FILE: B6-F-FL-4-T5HO-1-1

Efficiency: 82.0%

CANDELA DISTRIBUTION

Vertical Angle	Horizontal Angles					Zonal Lumens
	0	22.5	45	67.5	90	
0	1498	1498	1498	1498	1498	
5	1487	1516	1465	1490	1503	80
15	1394	1400	1407	1413	1407	337
25	1256	1273	1263	1271	1271	547
35	1048	1051	1069	1078	1060	656
45	846	846	850	855	860	668
55	621	626	621	625	627	590
65	418	420	421	415	417	454
75	239	235	229	228	225	287
85	84	80	75	71	68	123
90	11	10	9	7	6	
95	55	45	38	35	34	27
105	268	367	278	194	171	210
115	499	633	715	682	630	557
125	711	825	977	1018	1021	795
135	911	986	1116	1204	1211	851
145	1093	1120	1195	1266	1301	781
155	1205	1209	1253	1291	1315	626
165	1275	1275	1280	1292	1276	419
175	1288	1308	1296	1295	1306	185
180	1281	1281	1281	1281	1281	

COEFFICIENTS OF UTILIZATION (%)

Ceiling	80				70				50			
	70	50	30	10	70	50	30	10	50	30	10	
Wall	70	50	30	10	70	50	30	10	50	30	10	
0	87	87	87	87	80	80	80	80	67	67	67	
1	80	76	73	70	73	70	67	65	58	56	55	
2	72	66	61	57	66	61	57	53	51	48	45	
3	66	58	52	48	60	54	49	44	45	41	38	
4	60	52	45	40	55	48	42	38	40	36	32	
5	56	46	39	35	51	43	37	32	36	31	28	
6	51	41	35	30	47	38	32	28	32	28	24	
7	47	37	31	26	43	34	29	25	29	25	21	
8	44	34	27	23	40	31	26	22	27	22	19	
9	41	31	25	21	37	29	23	19	24	20	17	
10	38	28	22	18	35	26	21	17	23	18	15	

Based on floor reflectance of 20

LUMINANCE DATA (CD/M²)

Vertical Angle	Horizontal Angles		
	0	45	90
45	6978	4303	3868
55	6057	3249	2855
65	5184	2355	1985
75	4238	1427	1157
85	2788	546	396

3 T5HO

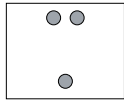

PHOTOMETRIC CURVE

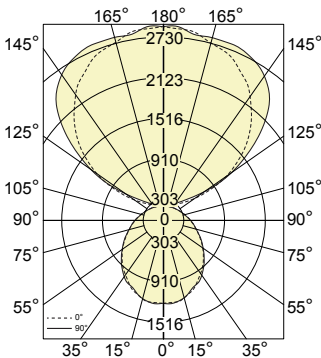

Test Lamp: 3x**F54T5HO**
 IES FILE: B6-F-FL-4-T5HO-1-2

Efficiency: 82.8%

CANDELA DISTRIBUTION

Vertical Angle	Horizontal Angles					Zonal Lumens
	0	22.5	45	67.5	90	
0	1477	1477	1477	1477	1477	
5	1470	1481	1447	1499	1487	79
15	1403	1397	1382	1420	1402	338
25	1245	1269	1257	1287	1277	545
35	1059	1054	1065	1082	1082	657
45	839	848	861	859	848	668
55	615	625	628	631	612	590
65	419	420	421	422	410	455
75	234	235	234	225	228	287
85	84	85	77	70	70	125
90	112	84	60	58	58	
95	567	658	538	396	343	44
105	1056	1230	1207	1144	1095	400
115	1507	1684	1807	1767	1721	1017
125	1897	2030	2199	2271	2285	1457
135	2240	2300	2425	2533	2562	1652
145	2478	2499	2573	2642	2669	1569
155	2597	2611	2624	2649	2658	1284
165	2685	2652	2619	2665	2648	862
175	2698	2689	2682	2642	2730	380
180	2721	2721	2721	2721	2721	

COEFFICIENTS OF UTILIZATION (%)

Ceiling	80				70				50			
	70	50	30	10	70	50	30	10	50	30	10	
Wall	70	50	30	10	70	50	30	10	50	30	10	
0	85	85	85	85	76	76	76	76	60	60	60	
1	77	74	71	68	69	66	64	61	52	51	49	
2	71	65	60	56	63	58	54	50	46	43	41	
3	64	57	51	46	57	51	46	42	41	37	34	
4	59	50	44	39	53	45	40	36	36	32	29	
5	54	45	38	33	48	40	35	30	32	28	25	
6	50	40	33	29	44	36	30	26	29	25	22	
7	46	36	29	25	41	32	27	23	26	22	19	
8	42	32	26	22	38	29	24	20	24	20	17	
9	39	30	23	19	35	27	22	18	22	18	15	
10	37	27	21	17	33	25	19	16	20	16	13	

Based on floor reflectance of 20

LUMINANCE DATA (CD/M²)

Vertical Angle	Horizontal Angles		
	0	45	90
45	6927	4358	3815
55	6005	3286	2788
65	5194	2355	1951
75	4159	1453	1173
85	2772	555	404

i All IES files for other lamping are available for download at: www.axislighting.com

● **PHOTOMETRIC DATA**

3 T5HO

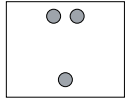

PHOTOMETRIC CURVE

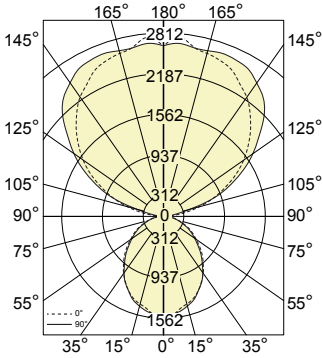

Test Lamp: 3xT5HO

IES FILE: B6-F-FL-4S-T5HO-1S-2

Efficiency: 82.3%

CANDELA DISTRIBUTION

Vertical Angle	Horizontal Angles					Zonal Lumens
	0	22.5	45	67.5	90	
0	1555	1555	1555	1555	1555	
5	1548	1527	1493	1496	1537	82
15	1412	1428	1447	1420	1444	344
25	1272	1262	1282	1263	1275	550
35	1069	1065	1049	1054	1054	655
45	840	831	834	825	808	653
55	603	614	603	581	577	567
65	413	410	399	390	386	434
75	232	226	218	209	211	271
85	82	75	72	66	63	117
90	10	11	8	6	6	
95	100	86	65	62	60	44
105	559	641	582	449	399	419
115	1039	1206	1190	1148	1126	1023
125	1513	1668	1746	1691	1691	1430
135	1912	2016	2178	2198	2211	1622
145	2262	2336	2452	2527	2535	1570
155	2518	2507	2598	2660	2689	1292
165	2635	2639	2674	2704	2680	872
175	2812	2634	2736	2694	2715	386
180	2671	2671	2671	2671	2671	

COEFFICIENTS OF UTILIZATION (%)

Ceiling	80				70				50			
	70	50	30	10	70	50	30	10	50	30	10	
Wall	70	50	30	10	70	50	30	10	50	30	10	
0	84	84	84	84	76	76	76	76	59	59	59	
1	77	73	70	68	69	66	63	61	52	50	49	
2	70	64	59	55	63	58	54	50	46	43	40	
3	64	56	51	46	57	51	46	42	40	37	34	
4	58	50	44	39	52	45	40	35	36	32	29	
5	54	44	38	33	48	40	35	30	32	28	25	
6	49	40	33	29	44	36	30	26	29	25	22	
7	45	36	29	25	41	32	27	23	26	22	19	
8	42	32	26	22	38	29	24	20	24	20	17	
9	39	29	23	19	35	27	21	18	22	18	15	
10	36	27	21	17	33	24	19	16	20	16	13	

Based on floor reflectance of 20

LUMINANCE DATA (CD/M²)

Vertical Angle	Horizontal Angles		
	0	45	90
45	6894	4116	3530
55	5844	3063	2539
65	5071	2153	1764
75	4054	1301	1036
85	2638	493	348

2 T8

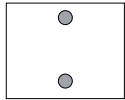

PHOTOMETRIC CURVE

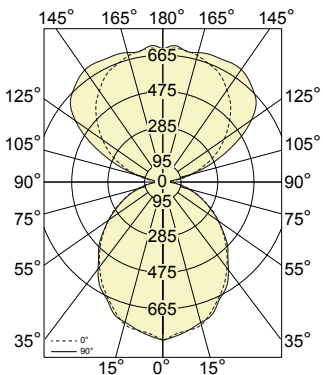

Test Lamp: 2xT8

IES FILE: B6-F-FL-4-T8-1-1

Efficiency: 80.0%

CANDELA DISTRIBUTION

Vertical Angle	Horizontal Angles					Zonal Lumens
	0	22.5	45	67.5	90	
0	854	854	854	854	854	
5	822	834	843	852	833	45
15	796	789	797	791	784	189
25	695	704	713	706	705	304
35	590	596	602	603	608	369
45	472	475	482	483	486	376
55	354	354	353	352	354	334
65	236	237	238	238	235	257
75	135	133	132	132	125	164
85	47	45	43	41	39	70
90	6	6	5	4	3	
95	33	31	21	20	20	16
105	153	207	183	162	148	139
115	279	356	404	375	363	320
125	397	466	547	582	575	447
135	507	549	627	678	687	478
145	596	619	670	712	735	436
155	667	680	700	722	731	350
165	705	708	711	715	722	234
175	724	723	729	726	737	104
180	716	716	716	716	716	

COEFFICIENTS OF UTILIZATION (%)

Ceiling	80				70				50			
	70	50	30	10	70	50	30	10	50	30	10	
Wall	70	50	30	10	70	50	30	10	50	30	10	
0	85	85	85	85	78	78	78	78	65	65	65	
1	78	74	71	68	71	68	65	63	57	55	53	
2	71	65	60	56	65	59	55	52	50	47	44	
3	64	57	51	46	59	52	47	43	44	40	37	
4	59	50	44	39	54	46	41	37	39	35	32	
5	54	45	38	34	49	41	36	31	35	31	27	
6	50	40	34	29	46	37	31	27	31	27	24	
7	46	36	30	26	42	34	28	24	28	24	21	
8	43	33	27	23	39	31	25	21	26	22	19	
9	40	30	24	20	36	28	23	19	24	20	17	
10	37	28	22	18	34	26	20	17	22	18	15	

Based on floor reflectance of 20

LUMINANCE DATA (CD/M²)

Vertical Angle	Horizontal Angles		
	0	45	90
45	3773	2349	2102
55	3345	1778	1548
65	2836	1284	1071
75	2329	788	618
85	1517	296	216

i All IES files for other lamping are available for download at: www.axislighting.com

● PHOTOMETRIC DATA

3 T8

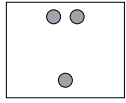

PHOTOMETRIC CURVE

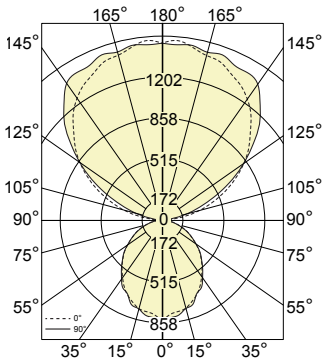

Test Lamp: 3x**F32T8**

IES FILE: B6-F-FL-4-T8-1-2

Efficiency: **78.6%**

CANDELA DISTRIBUTION

Vertical Angle	Horizontal Angles					Zonal Lumens
	0	22.5	45	67.5	90	
0	861	861	861	861	861	
5	810	843	846	828	838	45
15	781	798	784	781	784	189
25	703	698	712	711	698	305
35	590	593	600	607	605	369
45	474	476	483	483	478	376
55	353	352	355	360	354	335
65	241	237	238	234	239	257
75	131	133	133	129	128	163
85	48	47	43	41	39	70
90	7	6	5	4	3	
95	73	48	35	30	29	25
105	342	336	271	239	234	229
115	606	672	596	544	520	518
125	858	940	939	874	859	763
135	1070	1128	1210	1199	1184	889
145	1271	1288	1364	1401	1428	872
155	1389	1398	1443	1477	1465	718
165	1463	1484	1498	1503	1491	487
175	1545	1519	1517	1532	1509	217
180	1517	1517	1517	1517	1517	

COEFFICIENTS OF UTILIZATION (%)

Ceiling	80				70				50			
	70	50	30	10	70	50	30	10	50	30	10	
Wall	70	50	30	10	70	50	30	10	50	30	10	
0	81	81	81	81	73	73	73	73	57	57	57	
1	74	70	67	65	66	63	61	58	50	48	47	
2	67	61	57	53	60	55	51	48	44	41	39	
3	61	54	48	44	55	49	44	40	39	35	33	
4	56	48	42	37	50	43	38	34	34	31	28	
5	51	42	36	32	46	38	33	29	31	27	24	
6	47	38	32	27	42	34	29	25	28	24	21	
7	43	34	28	24	39	31	26	22	25	21	18	
8	40	31	25	21	36	28	23	19	23	19	16	
9	37	28	22	18	34	25	20	17	21	17	14	
10	35	26	20	16	31	23	18	15	19	15	13	

Based on floor reflectance of 20

LUMINANCE DATA (CD/M²)

Vertical Angle	Horizontal Angles		
	0	45	90
45	3789	2355	2068
55	3341	1790	1547
65	2900	1283	1092
75	2270	794	629
85	1541	302	217

3 T8

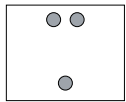

PHOTOMETRIC CURVE

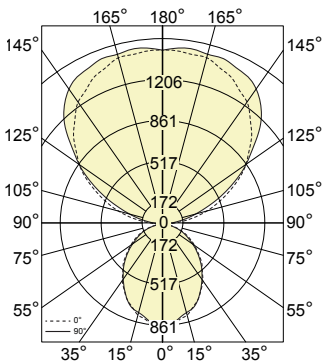

Test Lamp: 3x**F32T8**

IES FILE: B6-F-FL-4S-T8-1S-2

Efficiency: **78.3%**

CANDELA DISTRIBUTION

Vertical Angle	Horizontal Angles					Zonal Lumens
	0	22.5	45	67.5	90	
0	853	853	853	853	853	
5	878	850	851	847	862	46
15	810	800	797	797	788	192
25	717	713	705	710	717	308
35	601	596	597	596	588	367
45	476	472	471	464	460	369
55	346	346	341	333	331	322
65	235	229	223	219	216	244
75	129	128	123	119	120	154
85	45	44	40	37	36	66
90	7	6	5	4	3	
95	68	47	33	29	28	24
105	345	335	264	239	232	226
115	601	674	598	538	525	518
125	867	936	938	875	862	762
135	1085	1134	1211	1201	1186	893
145	1276	1301	1370	1405	1414	876
155	1401	1422	1449	1477	1495	722
165	1488	1495	1507	1511	1519	492
175	1504	1550	1544	1523	1529	218
180	1505	1505	1505	1505	1505	

COEFFICIENTS OF UTILIZATION (%)

Ceiling	80				70				50			
	70	50	30	10	70	50	30	10	50	30	10	
Wall	70	50	30	10	70	50	30	10	50	30	10	
0	80	80	80	80	72	72	72	72	57	57	57	
1	73	70	67	64	66	63	60	58	50	48	46	
2	67	61	56	53	60	55	51	48	44	41	39	
3	61	54	48	44	54	48	44	40	38	35	32	
4	56	47	42	37	50	43	38	34	34	31	28	
5	51	42	36	32	46	38	33	29	31	27	24	
6	47	38	32	27	42	34	29	25	27	24	21	
7	43	34	28	24	39	31	26	22	25	21	18	
8	40	31	25	21	36	28	23	19	23	19	16	
9	37	28	22	18	33	25	20	17	21	17	14	
10	35	26	20	16	31	23	18	15	19	15	13	

Based on floor reflectance of 20

LUMINANCE DATA (CD/M²)

Vertical Angle	Horizontal Angles		
	0	45	90
45	3776	2225	1920
55	3239	1654	1387
65	2795	1150	942
75	2186	698	558
85	1386	264	188

i All IES files for other lamping are available for download at: www.axislighting.com