



PENDANT MOUNT

PROJECT INFORMATION

Project:

Type:

Notes:

DIMENSIONS

SECTION VIEWS

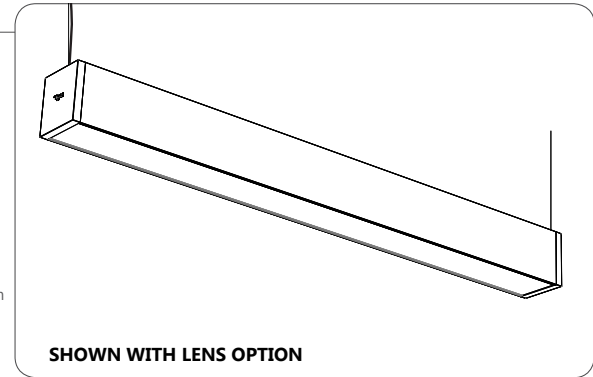
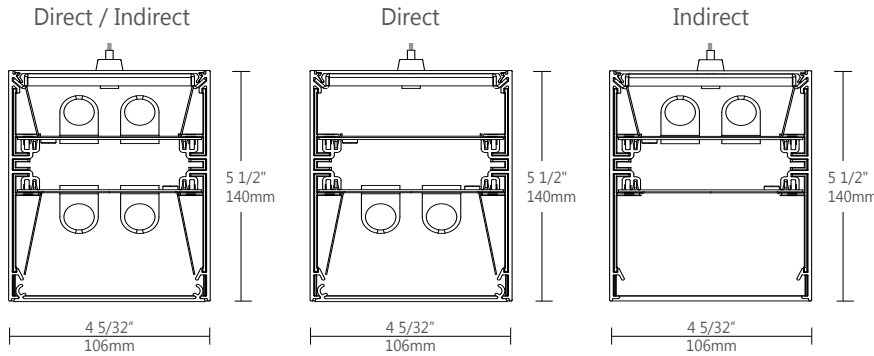

ORDERING CODE

1	2	3	4	5	6	7	8	9	10	11	12	13	14	15	16	17	18
---	---	---	---	---	---	---	---	---	----	----	----	----	----	----	----	----	----

PRODUCT SPECIFICATIONS

1	PRODUCT ID	2	OPTICS DIRECT	3	OPTICS INDIRECT	4	LENGTH/FT	5	SPECIFY LENGTH	6	LAMP
BB	pendant direct/indirect	S	satin lens	NO	no lens	2	2'	NL	nominal (3' & 4' lamps)	T5	T5
BBD	pendant direct	F	frosted lens ⁽¹⁾			3	3'	NL4	nominal (4' lamps only)	T5HO	T5HO
BBI	pendant indirect	PL	semi spec. para. louvers			4	4'	EX	exact (3' & 4' lamps)	T8	T8
		B	blank			5	5'	EX4	exact (4' lamps only)		
						6	6'				
						8	8'				
						12	12'				
						S#	System Run				
		(1) not recommended with staggered lampping									

7	DOWN LAMP	8	UP LAMP	9	MR	10	FINISH	11	VOLTAGE	12	BALLAST	13	CIRCUITS
0	0 lamp ⁽²⁾	0	0 lamp ⁽⁴⁾	M16#	MR 16 halogen	AP	aluminum paint	120	120V	D	dimming	1	1 regular
1	1 lamp	1	1 lamp	M16LED#	MR 16 LED	W	white	277	277V	E	instant start ⁽⁶⁾	2	2 regular
2	2 lamp	2	2 lamps			BLK	black	347	347V ⁽⁵⁾	ERS	program start	2A/B	2 alternating
+S	staggered ⁽³⁾	+S	staggered			C	custom	UNV	universal	BI	bi-level dimming	+E(#)	emergency section
												+NL(#)	night light section
												+GTD(#)	generator transfer device
												+M	MR
(2) Available only with indirect Staggered lampping and configurations must be the same up and down. (3) available with 1 lamp only		(4) Available only with direct Staggered lampping and configurations must be the same up and down		Add 9" per lamp Requires 120V or 277V				(5) Please consult factory		(6) Available with T8 lamp only			

14	MOUNTING/SUSPENSION	15	BATTERY	16	OTHER	17	IC CONTROLS (OPTIONAL)	18	CUSTOM (OPTIONAL)
CA#	drywall+cable length (36" std.)	B#	battery pack 4' sections	D	dust cover	DS#	daylight sensor	C	custom
CT9-#	TB/TG 9/16+cable length (36" std.)			F	fuse	OS#	occupancy sensor		
CT15-#	TB/TG15/16+cable length (36" std.)					DS+OS#	daylight+occupancy sensor		
CTS#	ST+cable length (36" std.)					DOS#	daylight&occupancy sensor		
SA#	drywall+stem length >48" (18" std.)								
See ceiling mounting guide for further details						See integrated controls guide for further details		Please specify	



● CONSTRUCTION

Housing	Extruded Aluminum (0.075" nominal) up to 70% Recycled Content
End Cap	Sheet Steel (18 ga)
Interior Brackets	Die Formed Sheet Steel (18 gauge)
Reflectors	White Powder Coated Sheet Steel (22 ga)
Louvers	Die Formed Semi-Specular Aluminum (22 ga)
White Louver	Die Formed Aluminum Painted White (22 ga)
Blank	Extruded Aluminum (0.075" nominal)
Lenses	Extruded Acrylic (0.070" nominal) Satin: 68% trans. Frosted: 85% trans.
Hanger	Die Formed Sheet Steel (16 gauge)
Suspension	Aircraft Cable or Ø 1/2" Stem
Cable Grips	Quick Connecting / Release

● WEIGHT

4 ft	14.5 lbs / 6.6 kg
8 ft	29.0 lbs / 13.2 Kg
12 ft	43.5 lbs / 19.7 Kg

● SYSTEM (S#)

BEAM 4 linear systems, with the use of a strong profile, allow for a nearly hair thin connection system of continuous runs. Lengths of 4', 8', 12' as well as custom lengths are available. Runs of BEAM 4 that are greater than 12' in length are designated as systems (S#). This means that the run is comprised of a combination of 4', 8' and/or 12' sections to be assembled on site using our joining system. For more information on systems and joining, please refer to the BEAM installation sheets available for download at www.axislighting.com.

● ELECTRICAL

Ballast	Electronic IS, Electronic Rapid Start, Dimming (0-10V, Line, EcoSystem, DALI), BI-level dimming With preinstalled ballast disconnect as per NEC & CEC
Emergency	Emergency battery pack or emergency circuit
Voltage	120V, 277V, 347V, UNV

i Incorporating these components may have limitations or effect the length of the luminaire, please contact factory for more details.

● FINISH

Aluminium paint, Powder Coated and custom finishes are also available.

● APPROVALS

Certified to UL and CUL standards
 Meets NYC requirements
 Suitable for damp locations.

● JOINERS

In order to allow very long runs of BEAM 4 luminaires, Axis has developed an effective joining system. Special care has been taken to maximize the performance of the joiner for each BEAM option.

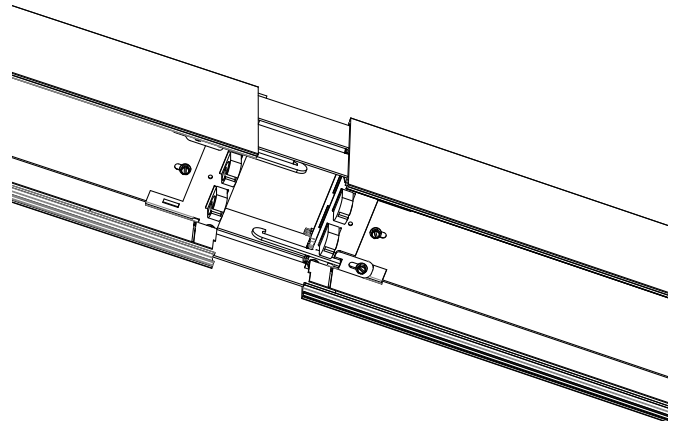

NOTE: Hang each system segment individually. Do not assemble system prior to hanging.

● STAGGERED LAMPING

When BEAM 4 is used in continuous runs longer than 4', staggered lamping can be used to eliminate the appearance of socket shadows at the ends of the lamps. BEAM 4 uses a staggered overlap of 4 different overlapping bracket lengths (3.5", 4", 4.5" and 5"), along with 3' and 4' lamps, allowing us to match almost any row length requirements with optimal results. For example 3 x 3' staggered T5 lamps can be used to completely illuminate the lens of an 8' nominal luminaire.

LAMP TYPE	T5	T5HO	T8
1 lamp	●	●	●

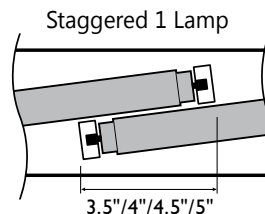

OPTICS

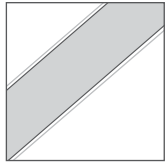

S satin lens

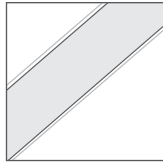

F frosted lens

SATIN & FROSTED LENS

(acrylic snap-in lens)
 satin: 68% trans.
 frosted: 85% trans.

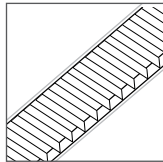

PL semi-specular parabolic louvers

LOUVERS

(semi-spec. parabolic louver)
 9/16" deep blades – 5/8" spacing
 72 blades per 4'

CORNERS

Unlit Corners - BEAM4

features a multitude of layout patterns with the use of a number of corners, 90° corner, T or X junctions.

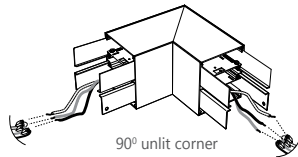

90° unlit corner

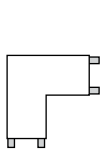

90° corner

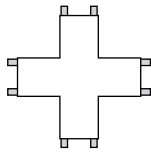

X junction

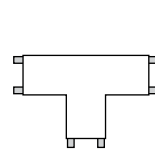

T junction

Lit Corners - In addition Axis offers Lit 90° Corners including Ceiling to Ceiling, Wall to Ceiling and Ceiling to Wall.

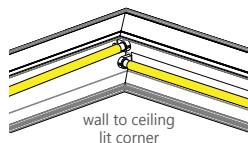

wall to ceiling lit corner

i For custom corner angles, please consult factory. Specifications sheets for all corners are available at: www.axislighting.com

MR16

Blank MR16 Halogens
MR16 LED
Quantity

Extruded Aluminum (0.075" nominal)
 2.0" diameter (35W / 50W)
 2.0" diameter

For every 4' fluorescent lamp section, there may be up to a maximum of 4 x MR16 lamps.

Spacing

Each MR16 is placed centered on a blank section 9" in length.

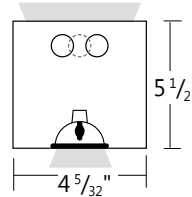

For a series of MR16's within a given section length, they will be spaced evenly on a longer blank section. The directed light of MR16 Halogen lamps are fixed downward.

Custom spacing may be available on special request.

Between fluorescent lamps sections

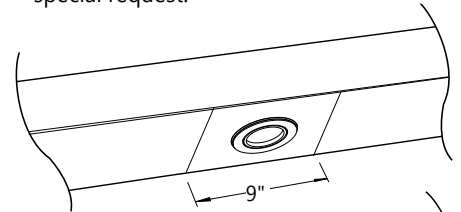

At luminaire ends

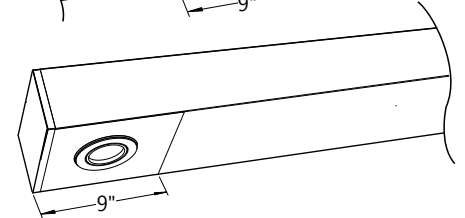

Several in a long blank section

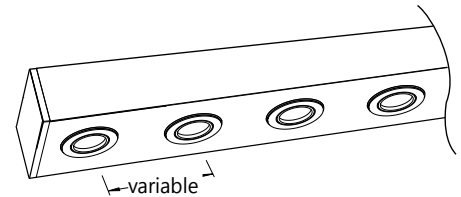

● MOUNTING SPACING END TO END

T5/T5HO LAMP	4'	(46 5/16" C.C.)
	8'	(92 5/8" C.C.)
	12'	(138 15/16" C.C.)

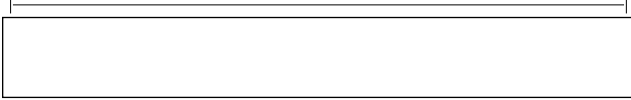

T8 LAMP	4'	(48" C.C.)
	8'	(96" C.C.)
	12'	(144" C.C.)

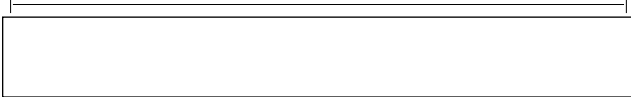

● MOUNTING SPACING STAGGERED

T5/T5HO 1 LAMP	T5/T5HO 2 LAMP
8' 3X3' (95 1/2" C.C.)	4' (50 5/16" C.C.)
8' 2X4' (88 5/8" C.C.)	8' (96 5/8" C.C.)
12' 3X4' (130 15/16" C.C.)	12' (142 15/16" C.C.)
12' 2X4'+2X3' (149 5/8" C.C.)	



T8 1 LAMP	T8 2 LAMP
8' (92" C.C.)	4' (52" C.C.)
12' (136" C.C.)	8' (100" C.C.)
	12' (148" C.C.)

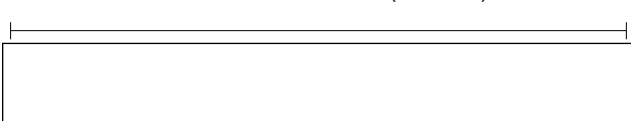

i Row configuration and mounting spacing file is available for download at: www.axislighting.com

● OTHER MOUNTING OPTIONS

BEAM 4 is also available with recessed, surface, wall, asymmetric, recessed wall and wall wash mounted options.

i Specification sheets and Installation sheets for all mounting for BEAM luminaires are available for download at www.axislighting.com

● MOUNTING OPTIONS

CT TILE CEILING - ON GRID

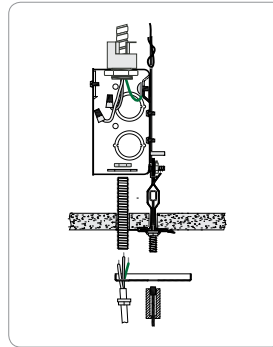

Power feed

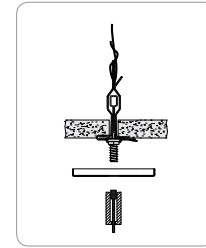

Non power feed

CA DRYWALL CEILING

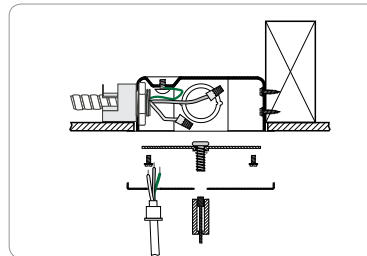

Power feed

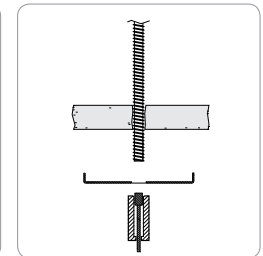

Non power feed

SA STEM MOUNT IN DRYWALL CEILING

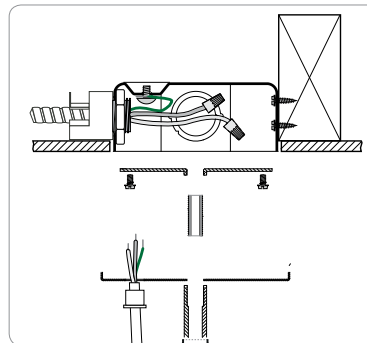

Power feed

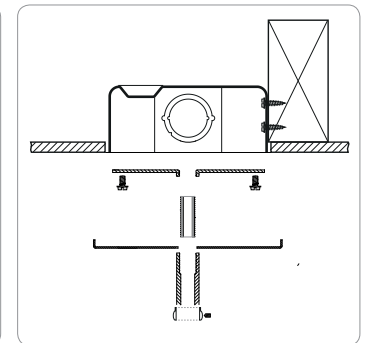

Non power feed

● INTEGRATED CONTROL OPTIONS

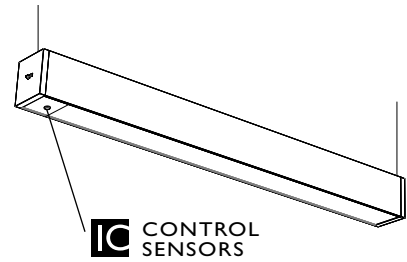

BEAM 4 luminaires allow the use of integrated controls such as daylight sensors (DS), occupancy sensors (OS), individual daylight sensors and occupancy sensors (DS+OS), and combination daylight/occupancy sensors (DOS). These options can be seamlessly integrated into our luminaires. The control system could be used to optimize the lighting of the space by reducing energy consumption through daylight harvesting and occupancy, thereby improving the overall interior environment and allowing for LEED credits.

- Consult factory for other options.
- Refer to IC brochure for more information.

SENSORS	BRAND	Model	TYPE	CODE	COMPATIBLE DIMMING BALLAST
Daylight Sensor (DS)	Lutron	EC-DIR-WH	Daylight	LD	EcoSystem
	Wattstopper	FD-301	Daylight	WD	0-10V
	Philips	Luxsense	Daylight	PL	0-10V
Occupancy Sensor (OS)	Wattstopper	FS-205	PIR Occupancy	WP1	Programmed Rapid Start
		FS-355	PIR Occupancy	WP2	Programmed Rapid Start
		FM-105	High Frequency Occupancy	WH	Programmed Rapid Start
Daylight & Occupancy Sensors (DOS)	Philips	Actilume	Daylight & PIR Occupancy	PA	DALI or 0-10V

● PHOTOMETRIC DATA

2 T5

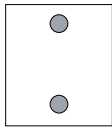

PHOTOMETRIC CURVE

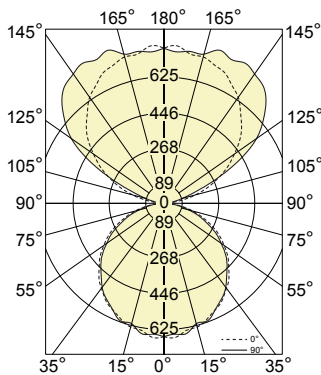

Test Lamp: 2x F28T5
 IES FILE: BB-S-FL-4-T5-1-1

Efficiency: 77.6%

CANDELA DISTRIBUTION

Vertical Angle	Horizontal Angles					Zonal Lumens
	0	22.5	45	67.5	90	
0	657	657	657	657	657	
5	662	633	654	643	647	35
15	631	627	629	629	613	150
25	584	590	587	580	587	250
35	528	526	525	520	524	318
45	451	445	449	447	439	345
55	361	361	351	349	343	329
65	259	253	248	242	236	267
75	147	141	136	134	126	171
85	47	44	36	33	31	67
90	6	5	3	2	2	
95	30	24	19	17	16	13
105	160	196	132	104	93	112
115	295	373	377	314	285	286
125	423	502	560	562	557	448
135	540	595	671	706	710	502
145	638	673	721	768	778	468
155	709	718	752	788	782	376
165	747	746	758	771	761	249
175	778	755	768	747	749	108
180	764	764	764	764	764	

COEFFICIENTS OF UTILIZATION (%)

Ceiling	80				70				50			
	70	50	30	10	70	50	30	10	50	30	10	
Wall	70	50	30	10	70	50	30	10	50	30	10	
0	82	82	82	82	75	75	75	75	62	62	62	
1	75	71	68	65	68	65	62	60	54	52	50	
2	68	62	57	53	62	57	53	49	47	44	41	
3	62	54	49	44	56	50	45	41	41	38	34	
4	56	48	42	37	51	44	39	34	36	32	29	
5	52	43	36	32	47	39	33	29	33	28	25	
6	47	38	32	27	43	35	29	25	29	25	22	
7	44	34	28	24	40	31	26	22	26	22	19	
8	41	31	25	21	37	29	23	19	24	20	17	
9	38	28	22	18	34	26	21	17	22	18	15	
10	35	26	20	16	32	24	19	15	20	16	13	

Based on floor reflectance of 20

LUMINANCE DATA (CD/M²)

Vertical Angle	Horizontal Angles		
	0	45	90
45	4510	2537	2162
55	4273	2022	1684
65	3895	1501	1187
75	3176	897	673
85	1863	272	184

i All IES files for other lamping are available for download at: www.axislighting.com

● **PHOTOMETRIC DATA**

2 T5

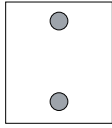

PHOTOMETRIC CURVE

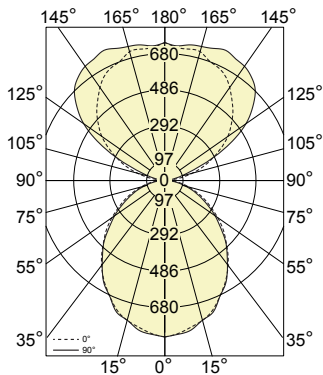

Test Lamp: 2xF28T5
 IES FILE: BB-F-FL-4-T5-1-1
Efficiency: 80.6%

CANDELA DISTRIBUTION

Vertical Angle	Horizontal Angles					Zonal Lumens
	0	22.5	45	67.5	90	
0	875	875	875	875	875	
5	858	854	858	864	863	45
15	810	813	817	810	808	196
25	720	724	728	719	721	313
35	610	613	608	610	608	376
45	481	480	477	477	477	378
55	357	354	346	341	339	329
65	238	234	228	222	217	250
75	133	132	123	118	113	155
85	46	42	36	32	30	63
90	6	4	3	2	1	
95	30	23	18	17	16	13
105	161	195	132	102	93	111
115	294	376	375	316	290	288
125	429	498	561	563	553	448
135	537	596	672	703	713	502
145	631	668	725	769	777	467
155	698	722	753	778	802	376
165	747	750	758	770	775	249
175	746	778	749	763	755	108
180	770	770	770	770	770	

COEFFICIENTS OF UTILIZATION (%)

Ceiling	80												70				50			
	Wall	70	50	30	10	70	50	30	10	50	30	10	50	30	10					
0	85	85	85	85	78	78	78	78	65	65	65									
1	78	75	71	69	71	68	66	63	57	55	53									
2	71	65	60	56	65	60	56	52	50	47	44									
3	65	57	52	47	59	53	48	44	44	40	37									
4	59	51	45	40	54	47	41	37	39	35	32									
5	55	45	39	34	50	42	36	32	35	31	28									
6	50	41	34	30	46	38	32	28	32	27	24									
7	46	37	30	26	42	34	28	24	29	24	21									
8	43	33	27	23	39	31	25	22	26	22	19									
9	40	30	24	20	37	28	23	19	24	20	17									
10	37	28	22	18	34	26	21	17	22	18	15									

Based on floor reflectance of 20

LUMINANCE DATA (CD/M²)

Vertical Angle	Horizontal Angles		
	0	45	90
45	4817	2695	2349
55	4221	1990	1665
65	3584	1383	1091
75	2868	810	602
85	1851	268	178

3 T5

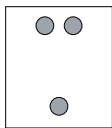

PHOTOMETRIC CURVE

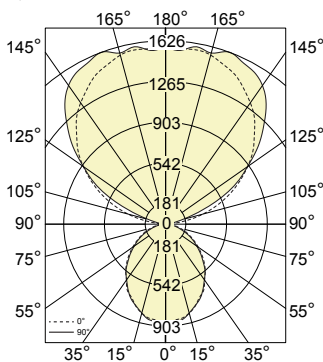

Test Lamp: 3xF28T5
 IES FILE: BB-F-FL-4-T5-1-2
Efficiency: 80.9%

CANDELA DISTRIBUTION

Vertical Angle	Horizontal Angles					Zonal Lumens
	0	22.5	45	67.5	90	
0	888	888	888	888	888	
5	856	869	863	861	868	45
15	817	811	814	816	816	196
25	715	720	729	724	728	313
35	606	607	608	616	602	375
45	488	483	476	475	474	379
55	356	355	351	341	339	330
65	235	234	230	221	220	249
75	134	132	121	116	113	155
85	47	43	36	32	30	63
90	6	5	3	2	2	
95	67	40	29	27	25	21
105	347	356	246	173	156	202
115	627	697	633	569	528	531
125	890	989	984	918	890	800
135	1115	1214	1278	1259	1233	938
145	1313	1379	1455	1480	1501	925
155	1462	1477	1546	1585	1594	764
165	1551	1550	1571	1612	1570	515
175	1562	1557	1567	1576	1546	224
180	1574	1574	1574	1574	1574	

COEFFICIENTS OF UTILIZATION (%)

Ceiling	80												70				50			
	Wall	70	50	30	10	70	50	30	10	50	30	10	50	30	10					
0	83	83	83	83	74	74	74	74	58	58	58									
1	76	72	69	66	68	65	62	60	51	49	48									
2	69	63	58	54	62	57	53	49	45	42	40									
3	63	55	50	45	56	50	45	41	40	36	33									
4	57	49	43	38	51	44	39	35	35	31	28									
5	53	44	37	33	47	39	34	30	31	27	24									
6	48	39	33	28	43	35	30	26	28	24	21									
7	45	35	29	25	40	32	26	23	26	22	19									
8	41	32	26	22	37	29	24	20	23	19	16									
9	38	29	23	19	34	26	21	18	21	17	15									
10	36	26	21	17	32	24	19	16	19	16	13									

Based on floor reflectance of 20

LUMINANCE DATA (CD/M²)

Vertical Angle	Horizontal Angles		
	0	45	90
45	4885	2689	2334
55	4217	2023	1664
65	3542	1394	1109
75	2887	798	602
85	1889	271	178

i All IES files for other lamping are available for download at: www.axislighting.com

● **PHOTOMETRIC DATA**

3 T5HO

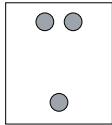

PHOTOMETRIC CURVE

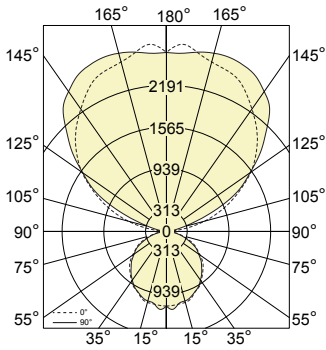

Test Lamp: 3x F54T5HO
 IES FILE: BB-S-FL-4-T5HO-1-2

Efficiency: 78.9%

CANDELA DISTRIBUTION

Vertical Angle	Horizontal Angles					Zonal Lumens
	0	22.5	45	67.5	90	
0	1118	1118	1118	1118	1118	
5	1115	1129	1141	1121	1172	61
15	1102	1071	1088	1077	1080	258
25	1009	1021	1021	1005	1005	430
35	911	920	899	900	891	549
45	779	770	773	764	748	593
55	619	617	609	605	590	564
65	454	439	433	424	419	463
75	253	253	236	227	228	297
85	85	73	64	57	53	116
90	11	9	5	4	3	
95	111	67	50	44	44	36
105	597	607	420	302	274	348
115	1074	1206	1087	986	917	917
125	1548	1713	1699	1587	1534	1380
135	1931	2098	2211	2161	2117	1618
145	2240	2381	2519	2567	2560	1594
155	2526	2547	2659	2745	2746	1318
165	2629	2673	2679	2741	2766	887
175	2816	2759	2671	2753	2680	389
180	2683	2683	2683	2683	2683	

COEFFICIENTS OF UTILIZATION (%)

Ceiling	80				70				50			
	70	50	30	10	70	50	30	10	50	30	10	
Wall	70	50	30	10	70	50	30	10	50	30	10	
0	81	81	81	81	72	72	72	72	56	56	56	
1	73	70	67	64	65	63	60	58	49	47	46	
2	67	61	56	52	59	55	51	47	43	40	38	
3	61	53	48	43	54	48	43	39	38	34	32	
4	55	47	41	36	49	42	37	33	33	30	27	
5	51	42	36	31	45	38	32	28	30	26	23	
6	47	37	31	27	41	34	28	24	27	23	20	
7	43	33	27	23	38	30	25	21	24	20	17	
8	40	30	24	20	35	27	22	18	22	18	15	
9	37	27	22	18	33	25	20	16	20	16	13	
10	34	25	19	16	31	23	18	15	18	14	12	

Based on floor reflectance of 20

LUMINANCE DATA (CD/M²)

Vertical Angle	Horizontal Angles		
	0	45	90
45	7793	4367	3685
55	7325	3507	2891
65	6835	2621	2110
75	5444	1557	1218
85	3390	476	312

2 T5HO

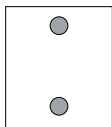

PHOTOMETRIC CURVE

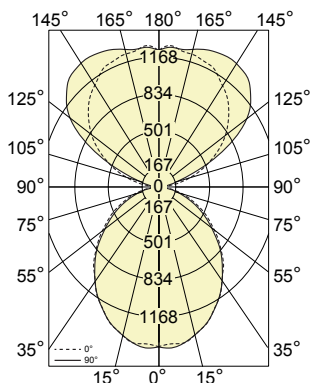

Test Lamp: 2x F54T5HO
 IES FILE: BB-F-FL-4-T5HO-1-1

Efficiency: 80.6%

CANDELA DISTRIBUTION

Vertical Angle	Horizontal Angles					Zonal Lumens
	0	22.5	45	67.5	90	
0	1487	1487	1487	1487	1487	
5	1464	1470	1478	1482	1502	80
15	1404	1396	1407	1402	1407	337
25	1246	1260	1246	1248	1249	540
35	1041	1048	1046	1045	1044	646
45	833	835	830	819	819	651
55	609	609	605	585	580	568
65	412	408	395	382	374	433
75	231	226	214	205	199	268
85	81	70	62	55	51	109
90	10	8	4	3	3	
95	51	40	32	28	28	22
105	279	340	229	176	166	192
115	508	645	652	544	492	495
125	739	864	965	972	950	771
135	931	1021	1156	1225	1220	864
145	1091	1150	1248	1321	1349	808
155	1224	1233	1301	1343	1372	649
165	1278	1286	1313	1333	1330	431
175	1325	1325	1295	1316	1308	187
180	1271	1271	1271	1271	1271	

COEFFICIENTS OF UTILIZATION (%)

Ceiling	80				70				50			
	70	50	30	10	70	50	30	10	50	30	10	
Wall	70	50	30	10	70	50	30	10	50	30	10	
0	86	86	86	86	78	78	78	78	65	65	65	
1	78	75	72	69	71	69	66	63	57	55	53	
2	71	65	60	56	65	60	56	52	50	47	44	
3	65	57	52	47	59	53	48	44	44	41	37	
4	59	51	45	40	54	47	41	37	39	35	32	
5	55	45	39	34	50	42	36	32	35	31	28	
6	50	41	34	30	46	38	32	28	32	27	24	
7	46	37	30	26	43	34	28	24	29	24	21	
8	43	33	27	23	39	31	25	22	26	22	19	
9	40	30	24	20	37	28	23	19	24	20	17	
10	37	28	22	18	34	26	21	17	22	18	15	

Based on floor reflectance of 20

LUMINANCE DATA (CD/M²)

Vertical Angle	Horizontal Angles		
	0	45	90
45	8331	4693	4034
55	7212	3481	2844
65	6201	2395	1884
75	4972	1413	1060
85	3256	461	302

i All IES files for other lamping are available for download at: www.axislighting.com

● **PHOTOMETRIC DATA**

3 T5HO

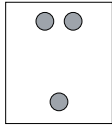

PHOTOMETRIC CURVE

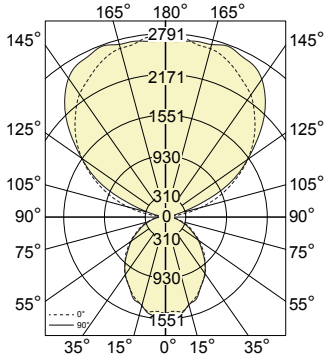

Test Lamp: 3x F54T5HO

IES FILE: BB-F-FL-4-T5HO-2-1

Efficiency: 80.9%

CANDELA DISTRIBUTION

Vertical Angle	Horizontal Angles					Zonal Lumens
	0	22.5	45	67.5	90	
0	1491	1491	1491	1491	1491	
5	1463	1484	1497	1494	1526	80
15	1401	1394	1406	1424	1398	338
25	1237	1239	1253	1258	1242	541
35	1063	1041	1042	1056	1050	646
45	842	832	831	823	812	653
55	617	617	599	590	593	570
65	412	413	395	382	378	431
75	227	225	211	204	196	265
85	81	72	62	56	54	109
90	12	8	5	4	3	
95	113	68	50	46	42	36
105	591	613	425	302	279	349
115	1076	1204	1085	980	924	914
125	1543	1716	1695	1586	1544	1382
135	1943	2093	2212	2167	2135	1618
145	2284	2349	2498	2547	2579	1588
155	2508	2568	2664	2718	2734	1320
165	2674	2671	2725	2743	2740	889
175	2773	2755	2708	2728	2704	389
180	2697	2697	2697	2697	2697	

COEFFICIENTS OF UTILIZATION (%)

Ceiling	80				70				50			
	70	50	30	10	70	50	30	10	50	30	10	
Wall	70	50	30	10	70	50	30	10	50	30	10	
0	83	83	83	83	74	74	74	74	59	59	59	
1	76	72	69	66	68	65	62	60	51	50	48	
2	69	63	58	54	62	57	53	49	45	42	40	
3	63	55	50	45	56	50	45	41	40	36	33	
4	57	49	43	38	51	44	39	35	35	31	28	
5	53	44	37	33	47	39	34	30	31	28	24	
6	48	39	33	28	43	35	30	26	28	24	21	
7	45	35	29	25	40	32	26	23	26	22	19	
8	41	32	26	22	37	29	24	20	23	19	16	
9	38	29	23	19	34	26	21	18	21	17	15	
10	36	26	21	17	32	24	19	16	19	16	13	

Based on floor reflectance of 20

LUMINANCE DATA (CD/M²)

Vertical Angle	Horizontal Angles		
	0	45	90
45	8429	4695	3999
55	7299	3448	2908
65	6197	2391	1905
75	4890	1392	1048
85	3236	465	316

2 T8

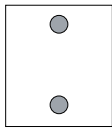

PHOTOMETRIC CURVE

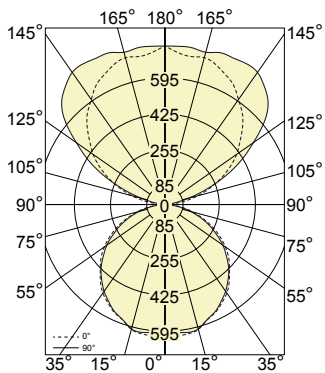

Test Lamp: 2x F32T8

IES FILE: BB-S-FL-4-T8-1-1

Efficiency: 74.7%

CANDELA DISTRIBUTION

Vertical Angle	Horizontal Angles					Zonal Lumens
	0	22.5	45	67.5	90	
0	626	626	626	626	626	
5	622	616	628	612	606	33
15	607	604	596	592	605	143
25	560	558	561	557	556	238
35	507	503	498	495	497	302
45	428	432	428	419	423	329
55	347	341	338	333	332	312
65	244	243	239	232	229	255
75	138	136	130	126	125	163
85	46	40	35	32	30	64
90	5	5	3	2	2	
95	32	25	18	17	16	13
105	161	193	153	126	113	120
115	290	363	353	320	307	290
125	411	483	545	523	507	427
135	516	571	648	678	685	482
145	602	640	700	742	758	450
155	673	690	728	756	760	362
165	714	716	732	741	740	241
175	716	753	727	736	746	105
180	745	745	745	745	745	

COEFFICIENTS OF UTILIZATION (%)

Ceiling	80				70				50			
	70	50	30	10	70	50	30	10	50	30	10	
Wall	70	50	30	10	70	50	30	10	50	30	10	
0	79	79	79	79	72	72	72	72	59	59	59	
1	72	69	66	63	65	63	60	58	52	50	48	
2	65	60	55	51	59	55	51	47	45	42	40	
3	59	52	47	42	54	48	43	39	40	36	33	
4	54	46	40	36	49	42	37	33	35	31	28	
5	50	41	35	30	45	38	32	28	31	27	24	
6	46	37	31	26	42	34	28	24	28	24	21	
7	42	33	27	23	38	30	25	21	25	21	18	
8	39	30	24	20	36	27	22	19	23	19	16	
9	36	27	22	18	33	25	20	17	21	17	14	
10	34	25	19	16	31	23	18	15	19	16	13	

Based on floor reflectance of 20

LUMINANCE DATA (CD/M²)

Vertical Angle	Horizontal Angles		
	0	45	90
45	4153	2339	2014
55	3984	1884	1573
65	3575	1399	1115
75	2898	832	645
85	1795	254	169

i All IES files for other lamping are available for download at: www.axislighting.com

PHOTOMETRIC DATA

2 T8

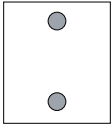

PHOTOMETRIC CURVE

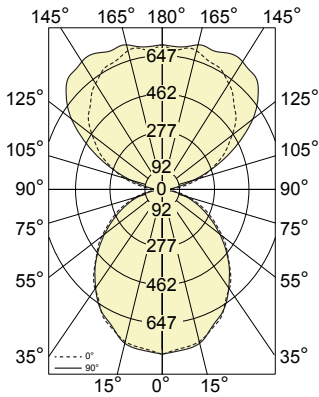

Test Lamp: 2xF32T8

IES FILE: BB-F-FL-4-T8-1-1

Efficiency: 77.9%

CANDELA DISTRIBUTION

Vertical Angle	Horizontal Angles					Zonal Lumens
	0	22.5	45	67.5	90	
0	829	829	829	829	829	
5	810	832	827	814	818	33
15	778	776	780	779	785	143
25	702	693	700	689	695	238
35	591	586	586	585	582	302
45	462	465	460	462	457	329
55	343	344	337	331	328	312
65	233	226	226	218	210	255
75	130	127	119	115	111	163
85	46	41	35	31	30	64
90	6	4	3	2	2	
95	33	24	19	16	16	13
105	159	192	155	124	115	120
115	284	363	355	318	304	290
125	405	486	541	525	513	427
135	522	573	643	677	680	482
145	610	642	701	743	749	450
155	680	689	724	747	765	362
165	716	722	732	746	758	241
175	710	745	727	735	728	105
180	735	735	735	735	735	

COEFFICIENTS OF UTILIZATION (%)

Ceiling	80				70				50			
	70	50	30	10	70	50	30	10	50	30	10	
Wall	70	50	30	10	70	50	30	10	50	30	10	
0	83	83	83	83	76	76	76	76	63	63	63	
1	76	72	69	66	69	66	64	61	55	53	52	
2	69	63	58	54	63	58	54	51	48	45	43	
3	63	56	50	45	57	51	46	42	43	39	36	
4	57	49	43	38	52	45	40	36	38	34	31	
5	53	44	38	33	48	40	35	31	34	30	27	
6	49	39	33	29	44	36	31	27	31	26	23	
7	45	35	29	25	41	33	27	23	28	24	20	
8	42	32	26	22	38	30	24	21	25	21	18	
9	39	29	24	20	36	27	22	19	23	19	16	
10	36	27	21	18	33	25	20	17	21	17	15	

Based on floor reflectance of 20

LUMINANCE DATA (CD/M²)

Vertical Angle	Horizontal Angles		
	0	45	90
45	4478	2513	2173
55	3934	1878	1554
65	3406	1322	1020
75	2731	763	574
85	1807	253	168

3 T8

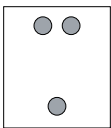

PHOTOMETRIC CURVE

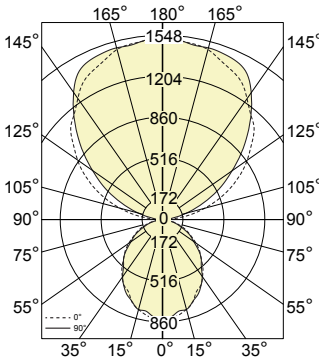

Test Lamp: 3xF32T8

IES FILE: BB-F-FL-4-T8-1-2

Efficiency: 74.4%

CANDELA DISTRIBUTION

Vertical Angle	Horizontal Angles					Zonal Lumens
	0	22.5	45	67.5	90	
0	825	825	825	825	825	
5	836	821	826	807	824	44
15	783	781	788	778	785	188
25	673	705	700	695	701	300
35	587	585	583	588	583	361
45	459	458	464	457	461	362
55	344	339	338	330	321	317
65	230	229	222	213	211	241
75	128	127	121	113	115	150
85	45	41	34	31	30	61
90	7	4	3	2	2	
95	69	38	26	21	21	19
105	352	284	221	193	182	192
115	626	612	497	444	435	453
125	871	915	809	743	710	683
135	1096	1142	1130	1039	1012	824
145	1248	1304	1347	1344	1309	841
155	1395	1425	1459	1483	1484	720
165	1494	1485	1524	1524	1511	492
175	1527	1543	1523	1548	1533	218
180	1530	1530	1530	1530	1530	

COEFFICIENTS OF UTILIZATION (%)

Ceiling	80				70				50			
	70	50	30	10	70	50	30	10	50	30	10	
Wall	70	50	30	10	70	50	30	10	50	30	10	
0	77	77	77	77	69	69	69	69	54	54	54	
1	70	67	64	61	63	60	58	56	48	46	45	
2	64	58	54	50	57	53	49	46	42	39	37	
3	58	51	46	42	52	46	42	38	37	34	31	
4	53	45	40	35	48	41	36	32	33	29	26	
5	49	40	34	30	44	36	31	28	29	26	23	
6	45	36	30	26	40	33	28	24	26	23	20	
7	41	32	27	23	37	29	24	21	24	20	17	
8	38	29	24	20	34	27	22	18	22	18	15	
9	36	27	21	18	32	24	20	16	20	16	14	
10	33	24	19	16	30	22	18	15	18	15	12	

Based on floor reflectance of 20

LUMINANCE DATA (CD/M²)

Vertical Angle	Horizontal Angles		
	0	45	90
45	4446	2537	2192
55	3945	1882	1519
65	3357	1298	1027
75	2693	769	592
85	1773	250	172

i All IES files for other lamping are available for download at: www.axislighting.com