

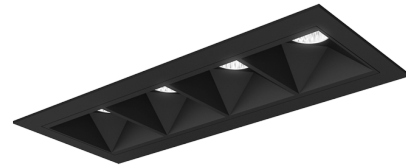

3G-RMZ4

4 LIGHT MINI ZOIE
TRIM & TRIMLESS



4 Light high performance mini downlight with 1.14" apertures
Features matte black or matte white faceted louvers
Regressed LED source with enhanced glare control
Shallow housing standard along with remodel housing option
Standard integral drivers and remote driver options with 1% dimming

ORDERING INFORMATION

PROJECT:	<input type="text"/>	TYPE:	<input type="text"/>
CATALOG #:	<input type="text"/>	DATE:	<input type="text"/>

CAT. NO	LUMEN OUTPUT	CRI	COLOR TEMP	BEAM ANGLE	VOLTAGE
3G-RMZ4	L2 - STANDARD OUTPUT <small>See performance chart for lumen output</small>	H90 - 90+CRI	27K - 2700K	33D - 33°	120 - 120V ¹
			30K - 3000K	50D - 50°	277 - 277V
			35K - 3500K		347 - 347V (REMOTE, 0-10V ONLY)
			40K - 4000K		

DRIVER	FLANGE TYPE & FINISH	HOUSING TYPE	OPTIONS
DIM - 0-10V (STANDARD 100-1%) LE - PHASE DIMMING ¹ (TRIAC/ELV, 100-1%, 120V ONLY) DHL2 - LUTRON (ECO SYSTEM "H", 100-1%) RDHL2 - REMOTE LUTRON (ECO SYSTEM "H", 100-1%) RDALI - REMOTE DALI (100-1%)	WT - WHITE TRIM & LOUVER BT - BLACK TRIM & LOUVER XTRW - TRIMLESS WITH WHITE LOUVER XTRB - TRIMLESS WITH BLACK LOUVER	RMD - REMODEL (NON-IC) NC - NEW CONSTRUCTION HOUSING ² SH - IC RATED SHALLOW HOUSING ² CP - CHICAGO PLENUM ²	BH - BAR HANGERS

¹ Forward phase/Reverse phase driver available in 120V only

² New Construction Housing, Shallow Housing and Chicago Plenum Housing can be used with remote drivers

PERFORMANCE CHART (Downlight)

90+ CRI (Based on 35K and 33° Beam Angle)

LUMEN OUTPUT (Per Downlight)	COLOR TEMP	SYSTEM WATTS	DELIVERED LUMENS	EFFICACY LM/W
L2 - STANDARD OUTPUT	27K	8.4W	552	66
L2 - STANDARD OUTPUT	30K	8.4W	584	70
L2 - STANDARD OUTPUT	35K	8.4W	620	74
L2 - STANDARD OUTPUT	40K	8.4W	636	76

EDITION 01/19



TECHNICAL**HOUSING**

IC rated shallow housing, and Chicago Plenum housing options available
Remodel housing available (Remote driver required for Lutron EcoSystem and eldoLED Dali)
Maximum ceiling thickness of 1". Consult factory for modifications
Housings are rated for #12 AWG, (4 in, 4 out), 90°C conductors and through branch wiring

FACETED LOUVER

1.14" aperture with regressed LED source for enhanced glare control
Matte black or matte white faceted louver finish

TRIM

Cast aluminum trim flange with powder coated finish and minimal 0.300" overlap

TRIMLESS

Mudding flange with integral blocking support installs flush with ceiling

OPTICS

Proprietary polycarbonate multi-faceted reflectors
Available in 33° and 50°

ELECTRICAL

Standard 0-10V, 100-1% dimming with integral driver
120V Forward Phase/Reverse Phase driver option with 100-1% dimming
Remote Lutron EcoSystem and eldoLED Dali options (100-1% dimming)
All integral driver option easily accessible through the aperture

LED SYSTEM

Osram LED source
Color consistency < 2 SDCM
Standard 90+CRI
Available in 27K, 30K, 35K, and 40K
Average rated life of > 50,000 hours
5-year warranty

MOUNTING

Trim fixture designed for use in drywall, wood, acoustic ceiling tiles, and other ceiling materials
Trimless fixture designed for use in drywall, mud-in ceiling applications
Recommended ceiling cut-out: (1 ½" x 4 ⅞") All housing options
Adjustable bar hangers extend from 14" to 26" and can be cut in-field for narrow stud spacing

LISTING

ETL listed and tested to UL standards. Suitable for dry and damp locations

WARRANTY

5 Year warranty on LED and drivers
Manufacturer 1-year warranty for defects in material and workmanship under normal use
Ambient temperature at fixture should not exceed 25°C

TRIM HOUSING OPTIONS

RMD - Remodel (Non-IC) (Remote driver for Lutron EcoSystem and eldoLED Dali)

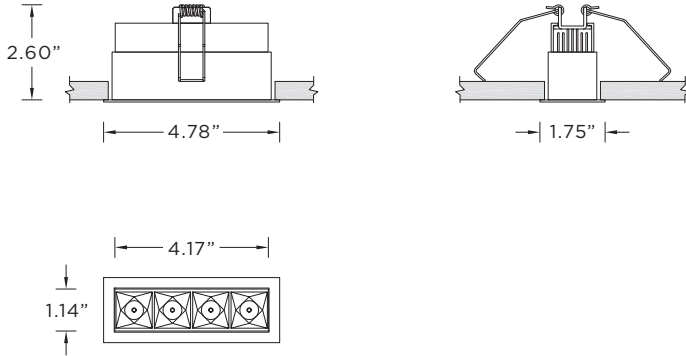

NC - New Construction Housing
SH - Shallow Housing (IC Rated)
CP - Chicago Plenum Housing

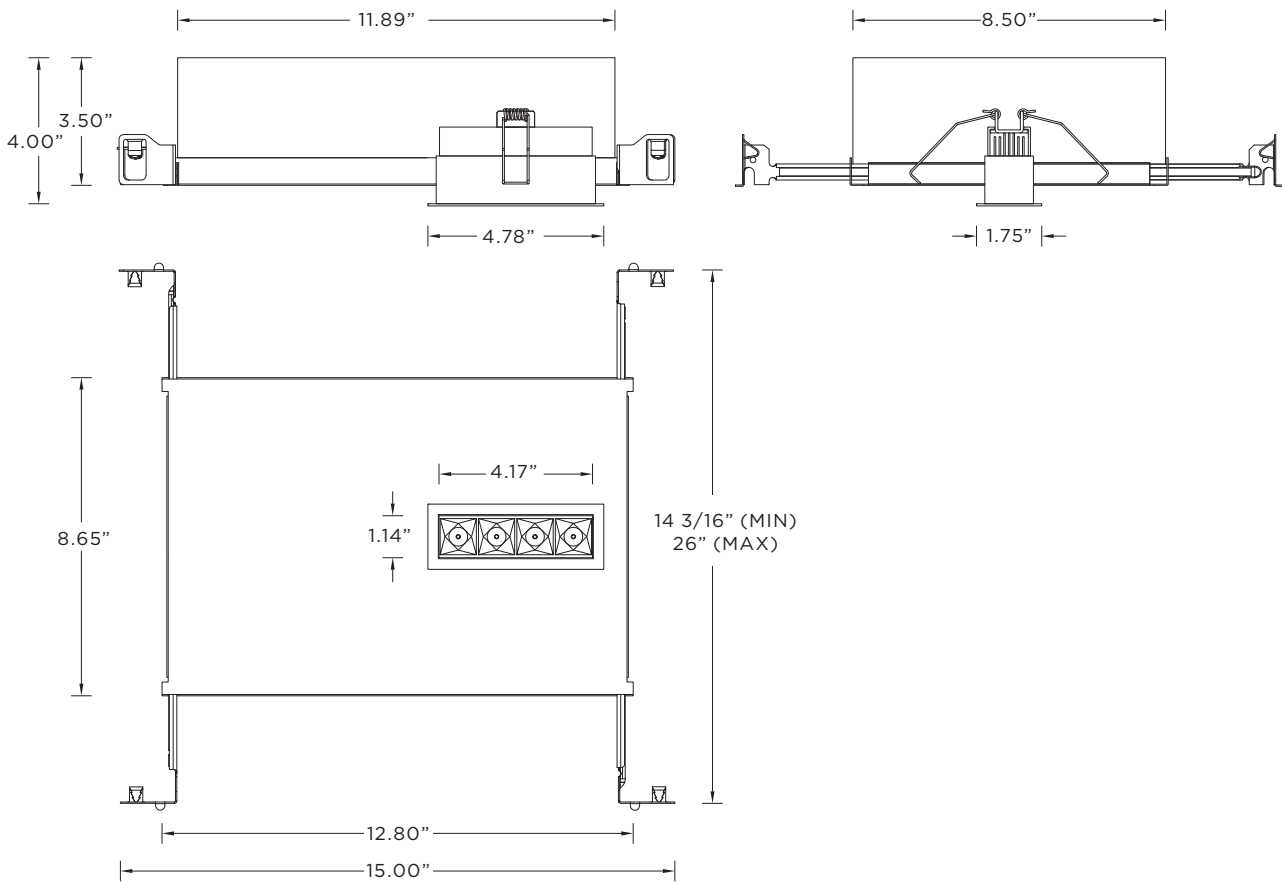

TRIMLESS HOUSING OPTIONS

RMD - Remodel (Non-IC) (Remote driver for Lutron EcoSystem and eldoLED Dali)

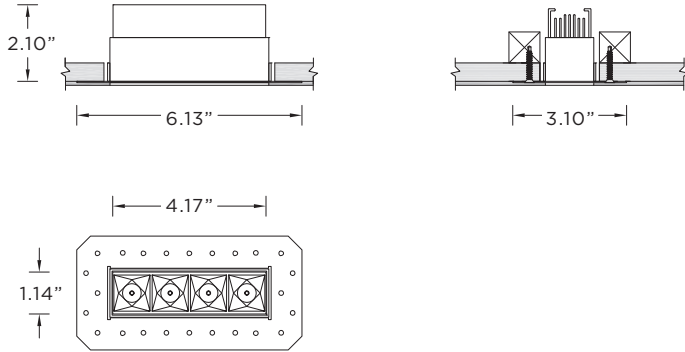

NC - New Construction Housing
SH - Shallow Housing (IC Rated)
CP - Chicago Plenum Housing

